

# CRX-K ANSI Grade 1 Cylindrical Lock with Ligature Resistant Trim-Knob

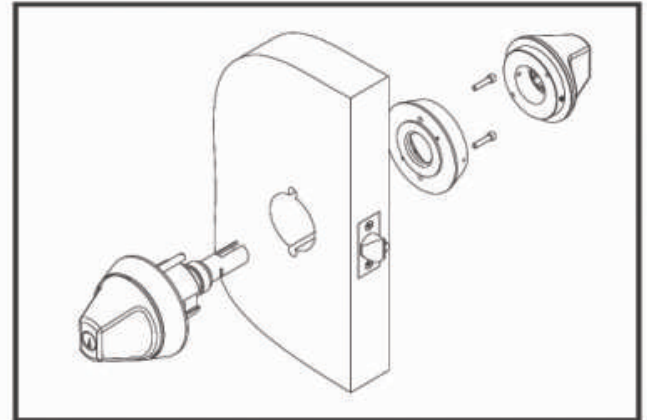

All locks provided are non-handed and 3 hour UL fire listed. The latch and dead latch are sintered stainless steel. The lock chassis is heavy duty wrought steel construction. Springs are tensioned for knob use and provide long life and smooth operation. Knobs are of stainless steel construction. Locks meet all requirements for ANSI grade 1 series 4000 locks. Locks fit into a standard ANSI 161 door preparation. 32D Finish. Schlage C keyway, standard



### Important Note:

It is TownSteel's position that if any of our keyed locks are to be used less cylinder, whether I.C. or standard, and another manufacturer's cylinder is to be used in place of the TownSteel original manufacturer's cylinder, that a sample of that product be provided to TownSteel in advance for testing.

How To Order	
Trim	CRX-K Ligature Resistant Knob Grade 1 Cylindrical Lock
Function	Please Refer to Function Sheet
<b>Example</b>	<b>CRX-K-84</b>
1. Ligature Resistant Knob Cylindrical	_____
2. Function	_____

