

JACK NUT INSTALLATION KIT

CONTENTS

ONE JACK NUT INSTALLATION TOOL

1 - 5M MANDREL INSTALLED IN INSTALLATION TOOL

50 - 5M x .75 FLAT HEAD PHILLIPS MACHINE SCREW

50 - 5M JACK NUTS

1 - 3M MANDREL

1 - 4M MANDREL

1 - 6M MANDREL

TO REORDER ADDITIONAL JACK NUTS AND SCREWS

USE P/N JN-50

PACKAGE CONSISTS OF

50 - 5M JACK NUTS

50 - 5M x .75 FLAT HEAD PHILLIPS MACHINE SCREWS

MODEL JN-1 JACK NUT INSTALLATION TOOL



ALARM CONTROLS CORPORATION

"QUALITY SECURITY EQUIPMENT SINCE 1971"

19 BRANDYWINE DRIVE P.O. BOX 280

DEER PARK, NY 11729

PH: 800 645-5538 FAX: 631 586-4220

EMAIL: INFO@ALARMCONTROLS.COM

WWW.ALARMCONTROLS.COM



ALARM CONTROLS CORPORATION

"QUALITY SECURITY EQUIPMENT SINCE 1971"

19 BRANDYWINE DRIVE P.O. BOX 280

DEER PARK, NY 11729

PH: 800 645-5538 FAX: 631 586-4220

EMAIL: INFO@ALARMCONTROLS.COM

WWW.ALARMCONTROLS.COM

JACK NUT INSTALLATION TOOL

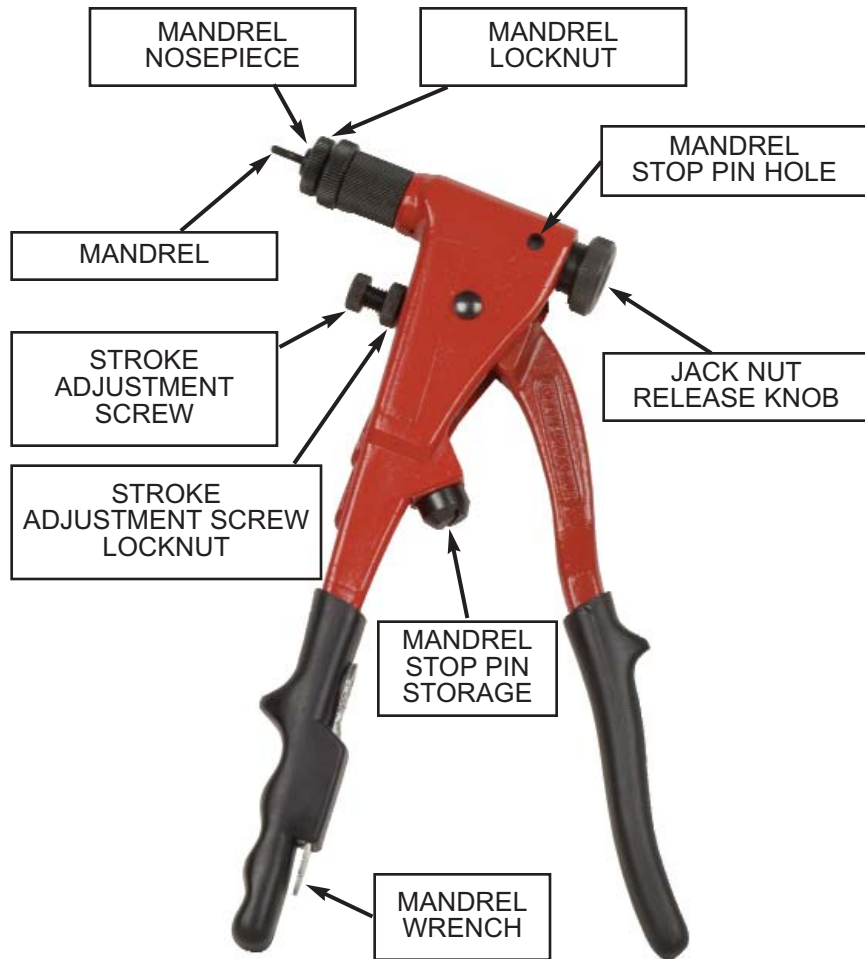

TO CHANGE MANDREL

(JACK NUT TOOL HAS 5M MANDREL INSTALLED)

- STEP 1** REMOVE STOP PIN FROM STORAGE COMPARTMENT.
- STEP 2** ROTATE JACK NUT RELEASE KNOB UNTIL THE STOP PIN HOLES LINE-UP AND INSERT STOP PIN.
- STEP 3** UN-SCREW MANDREL NOSEPIECE. REMOVE LOCK NUT FROM NOSEPIECE.
- STEP 4** USE MANDREL WRENCH TO UN-SCREW MANDREL. ROTATE WRENCH CLOCKWISE TO UN-SCREW.
- STEP 5** RE-ASSEMBLE NOSEPIECE WITH LOCK NUT INSTALLED.

JACK NUT INSTALLATION

STEP 1

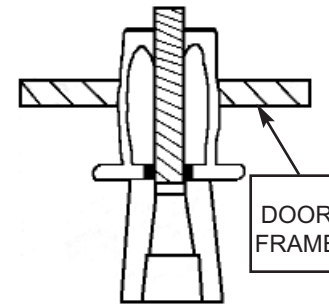

THREAD JACK NUT ONTO THE MANDREL OF THE INSTALLATION TOOL. THEN PUSH THE JACK NUT ALL THE WAY INTO THE PRE-DRILLED HOLE, (25/64" DRILL), UNTIL THE FLANGE OF THE JACK NUT IS FIRMLY AGAINST DOOR FRAME.

STEP 2

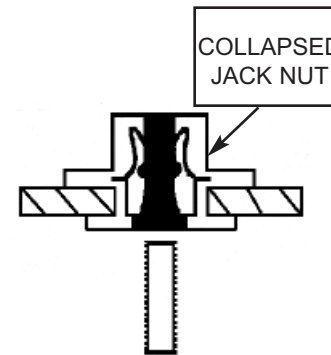

SQUEEZE HANDLES OF INSTALLATION TOOL UNTIL JACK NUT IS FULLY COLLAPSED. THEN UN-SCREW MANDREL WITH THE JACK NUT RELEASE KNOB.

STEP 3

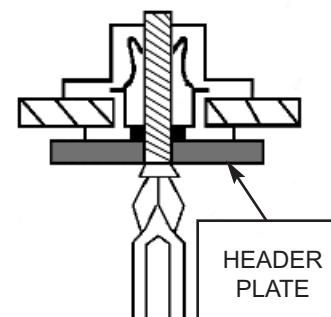

PASS FLAT HEAD 5M MACHINE SCREW THROUGH HEADER PLATE AND TIGHTEN SCREW UNTIL SNUG.