

# SpectrAlert Advance Weatherproof Plate

For use with models WTP-SP, WTP-SPW



**SPECIFICATIONS**

Operating Temperature: -40° F to 151° F (-40° C to 66° C)  
 Enclosure Rating: Meets NEMA 3R, IP22 rating requirements

WALL PRODUCT	LENGTH	WIDTH	DEPTH FROM WALL
Speaker Strobe	7.25"	6.26"	3.0" Including Speaker and Lens
Speaker	7.25"	6.26"	1.3" Including Speaker

**Note:** This product may only be installed in conjunction with an outdoor SpectrAlert Advance Speaker or Speaker Strobe

**Models:** SPRK-R, SPSRK-R, SPWK-R, SPSWK-R, SPWK, SPRK, SPSWK, SPSWK-P, SPSRK, SPSRK-P (-R models ship minus the outdoor back box, standard outdoor and -P models ship with an outdoor back box which is not needed when using the weatherproof plate)

**Notice:** This manual shall be left with the owner/user of this equipment.

**Note:** This product meets NEMA 3R for indoor or outdoor use to provide a degree of protection against falling dirt, rain, sleet, or snow; and that will be undamaged by the external formation of ice on the enclosure.

**GENERAL DESCRIPTION**

For installation with SpectrAlert Advance outdoor or outdoor replacement (-R) speakers and speaker strobes. This accessory plate allows an outdoor unit to be flush mounted on a number of different surfaces including brick, ceramic tile, concrete and masonry brick. The weatherproof plate is offered in red and white and is sold separately from the device.

**INSTALLATION:**

- The WTP-SP series of products may be used indoors or outdoors. They must be installed using the proper SpectrAlert Advance K series product. Do not attempt to use weatherproof plates with devices other than those specified for use with this product.
- Attach device mounting plate to the WTP-SP as shown in Fig 1. The WTP-SP is compatible with 4x4x2-1/8" back boxes.
  - Check orientation of the back box to the WTP-SP plate and observe which holes will be used for mounting to the back box
  - Place Well Nuts (A) into the two holes that will NOT be used in mounting the WTP-SP to the back box (See Fig. 1).
  - Place the device mounting plate on the WTP-SP and secure using the two #8-32 x 1/2" pan head screws (B) into the Well Nuts.
  - Secure the WTP-SP and device mounting plate assembly to the back box (C) using the two #8-32 x 2" pan head screws.
  - Tighten screws until the WTP-SP assembly contacts the wall surface evenly.
- It is the responsibility of the installer to make sure that all openings and connections are sealed properly. An outdoor rated silicon caulk (not supplied) may be applied around the WTP-SP to fill in around grout lines or uneven surfaces.
- Connect field wiring to terminals. Please follow instruction manual supplied with the device.
- Attach the device to the mounting plate by hooking the tabs on the device housing into the grooves on the mounting plate. Then, swing product into position to engage the pins on the device with the terminals on the mounting plate. Make sure that the tabs on the back are fully engaged with the mounting plate.
- Secure the device to the WTP-SP (See Fig. 2), using the four #8-32 x 3/8" flat head screws (D).

**FIGURE 1: WTP-SP AND DEVICE MOUNTING PLATE ASSEMBLY AND ATTACHMENT TO BACK BOX.**

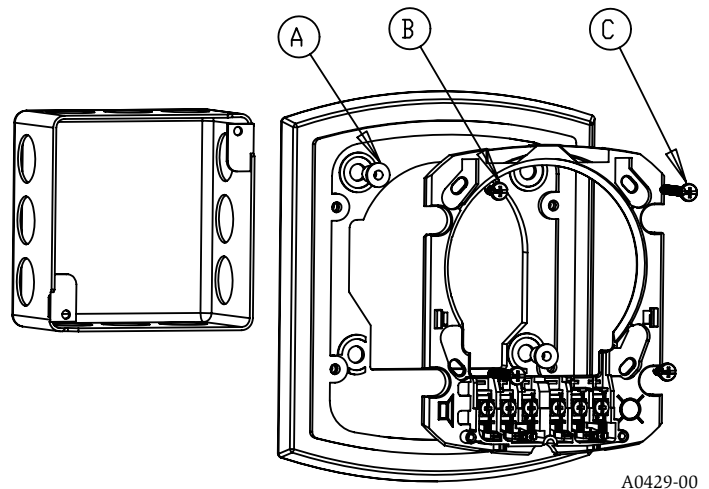

**FIGURE 2: DEVICE AND WTP-SP ASSEMBLY.**

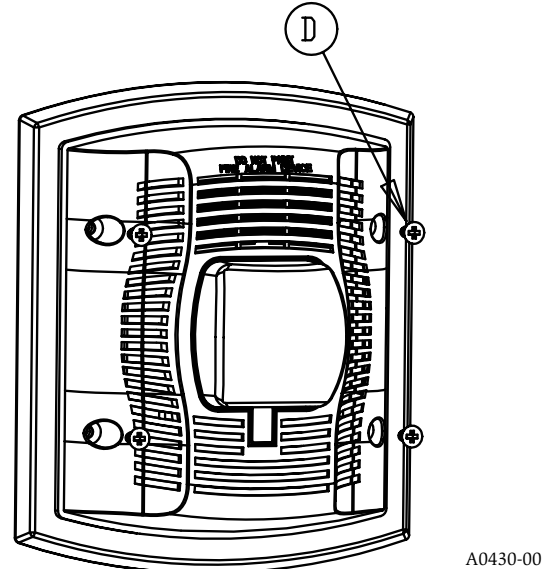

**Please refer to insert for the Limitations of Fire Alarm Systems**

**THREE-YEAR LIMITED WARRANTY**

System Sensor warrants its enclosed product to be free from defects in materials and workmanship under normal use and service for a period of three years from date of manufacture. System Sensor makes no other express warranty for this product. No agent, representative, dealer, or employee of the Company has the authority to increase or alter the obligations or limitations of this Warranty. The Company's obligation of this Warranty shall be limited to the replacement of any part of the product which is found to be defective in materials or workmanship under normal use and service during the three year period commencing with the date of manufacture. After phoning System Sensor's toll free number 800-SENSOR2 (736-7672) for a Return Authorization number, send defective units postage prepaid to: System Sensor, Returns Department, RA # \_\_\_\_\_, 3825

Ohio Avenue, St. Charles, IL 60174. Please include a note describing the malfunction and suspected cause of failure. The Company shall not be obligated to replace units which are found to be defective because of damage, unreasonable use, modifications, or alterations occurring after the date of manufacture. In no case shall the Company be liable for any consequential or incidental damages for breach of this or any other Warranty, expressed or implied whatsoever, even if the loss or damage is caused by the Company's negligence or fault. Some states do not allow the exclusion or limitation of incidental or consequential damages, so the above limitation or exclusion may not apply to you. This Warranty gives you specific legal rights, and you may also have other rights which vary from state to state.