

# AutoDome 600 Series Analog PTZ Camera

www.boschsecurity.com



- ▶ Choice of 550 TVL 36x or 28x day/night cameras with 12x digital zoom and wide dynamic range
- ▶ Progressive scan provides smooth and clear images when viewing details in a moving image
- ▶ Sodium Vapor White Balance mode restores objects to their original color
- ▶ AutoTrack II automated motion tracking
- ▶ Advanced privacy masking

The AutoDome 600 Series is an easy to install PTZ camera that delivers superb video in all indoor and outdoor applications. The camera features day/night functionality for high quality images in low light conditions. This discrete, high-speed dome camera ensures reliable, uncompromised functionality in diverse environments across various applications.

### AutoDome 600 Series highlights

The AutoDome delivers state-of-the-art technology and features that far exceed other PTZ cameras. The cameras achieve a high horizontal resolution of 550 TV lines enabling the reproduction of clear and detailed images.

#### Wide Dynamic Range

The AutoDome features Wide Dynamic Range (WDR) technology that allows for the capture of clear images from both bright and dark areas in the same frame. WDR ensures that bright areas are not saturated and that dark areas are not too dark.

#### Progressive scan

The AutoDome camera is ideally suited for moving imaging applications. The progressive scan technology incorporated into the camera provides smooth and clear images when viewing images from a moving camera.

#### Sodium vapor lamp white balance

The AutoDome is an exceptional performer when shooting under a sodium vapor lamp (a street lamp or tunnel lamp, for example). Images under these conditions may have a yellowish tint, which may make identification difficult. In the Sodium Vapor White Balance mode, the AutoDome automatically compensates for the light from a sodium vapor lamp to restore objects to their original color.

### System Overview

The AutoDome 600 Series offers variable pan and tilt speeds, and the AutoPivot feature ensures optimal camera control and viewing at all zoom levels. These high-performance zoom autofocus cameras incorporate the latest digital imaging technology with excellent sensitivity and resolution. With 99 user-defined presets as well as tour and AutoPan modes, The AutoDome 600 Series is not small on features. The AutoDome 600 Series adds real intelligence to your video surveillance applications. Equipped with AutoTrack II, Bosch's award-winning motion tracking software, built-in image stabilization, motion detection, and a sophisticated alarm handling "rules" engine, the AutoDome 600 Series incorporates advanced, intelligent video features unmatched by any other camera system.

The AutoDome 600 Series supports standard and optional video and data transmission methods, including Bilinx (over coax and UTP) and fiber optic. Remote control, configuration, and firmware updates can also be performed over these cables, offering you unparalleled control of your cameras. Cable compensation provides extended coaxial and UTP distance runs while preventing the image quality degradation caused by signal losses from long cable lengths.

### Functions

The following are some of the features that make the AutoDome 600 Series the most flexible PTZ dome camera systems in the security industry.

#### High-performance PTZ day/night cameras

Image control and quality are integral aspects of any PTZ dome camera, and the AutoDome delivers. The AutoDome 600 Series camera has a 1/4-in. CCD sensor, with 4CIF/D1 resolution and sensitivity to below 1.0 lux and is available with a choice of 28x and the industry-leading 36x optical zoom lens, and all 600 Series systems offer a full 12x digital zoom.

Both camera options provide 550 TVL of horizontal resolution for outstanding clarity and image detail. The cameras also incorporate technology that dramatically improves the dynamic range by 128 times. Also known as WDR (wide-dynamic range), it results in clear image reproduction in extreme high-contrast environments. The AutoScaling (proportional zoom) and AutoPivot (automatically rotates and flips the camera) features ensure optimal control.

Day/night capabilities and outstanding sensitivity make AutoDome 600 Series cameras exceptional performers in all lighting conditions. In low light, these cameras automatically switch from color to monochrome by removing the IR filter to boost the infrared illumination sensitivity, while maintaining superior image quality. For operation in the darkest conditions, the SensUp control feature automatically reduces the shutter speed to as little as one second. This increases sensitivity by more than 50 times.

#### Accurate control and positioning

With super-quick, 360° per-second pan and 100° per-second tilt speeds; the AutoDome 600 Series outperforms other domes in its class. The 600 Series supports 99 pre-positions and two styles of Guard Tours: Preset and Record/Playback. The preset tour has capability for up to 99 pre-positions with a configurable dwell time between pre-positions, and can be customized as to the order and frequency each preset is visited. The AutoDome 600 Series also provides support for two recorded tours, which have a combined duration of 15 minutes of movements. These are recorded macros of an operator's movements, including pan, tilt, and zoom activities, and can be played back in a continuous manner.

Supported menu languages include: English, Czech, Dutch, French, German, Italian, Polish, Portuguese, Russian and Spanish.

#### AutoTrack II

Bosch introduced the industry's first automated motion tracking system, and now we've made this award-winning technology even better. The AutoDome 600 Series contains an advanced DSP that provides real-time video processing for incredibly smooth object tracking.

AutoTrack II utilizes Bosch's unique "virtual masking" technology. These "invisible" masks are created to act just like privacy masks, except that only the AutoTrack can see them – and it knows to ignore any motion behind them. This enables the AutoTrack to ignore extraneous background motion, such as a tree blowing in the wind, making it ideal for both indoor and outdoor applications.

#### Video motion detection (VMD)

With AutoDome, you can create a "region of interest" within a preset position where motion is to be detected. The AutoDome 600 Series supports a total of 10 individual regions of interest (one per pre-position). VMD also takes advantage of virtual masking to ignore areas of unwanted motion.

#### Image stabilization

As PTZ cameras continue to improve their optical zoom capabilities, image stabilization becomes critical to eliminate movement caused by unstable camera mounts. A mere quarter-inch of movement of the camera mount can shift the field of view by more than 20 feet when the camera is zoomed to a high value. This can render images unusable.

Image stabilization algorithms included with the AutoDome 600 Series reduces camera shake in both the vertical and horizontal axis, resulting in exceptional image clarity (pixel displacement up to +/- 10% for frequencies up to 10 Hz). Bosch's unique image stabilization solution does not reduce camera sensitivity, unlike competitive systems.

#### Alarm management

The AutoDome 600 Series takes alarm handling to new levels of flexibility and power.

#### Inputs and outputs

The AutoDome 600 Series can handle seven alarm inputs, two of which are analog inputs that can be programmed for EOLR (End-of-Line Resistor) supervision whenever true security applications require it. These inputs enable the dome to "sense" if the contact is opened or closed and whether the wire has been tampered with (either by being cut or shorted). In addition, the AutoDome 600 Series supports four outputs: one relay rated at two amps and three additional open collectors for driving external devices. Each can be programmed individually.

### Advanced alarm control

The AutoDome 600 advanced alarm control uses sophisticated rules-based logic to determine how to manage alarms. In its most basic form, a “rule” could define which input(s) should activate which output(s). In a more complex form, inputs and outputs can be combined with pre-defined or user-specified keyboard commands to perform advanced dome functions. There is virtually no limit to the number of combinations that you can program, making the standard software in the dome ready for any application.

### Superior privacy masking

The AutoDome 600 Series allows for a total of 24 individual privacy masks, with up to eight displayed in the same scene. Unlike conventional privacy masks, these can each be programmed with three, four, or even five corners to cover more complex shapes. Each mask changes size and shape smoothly and quickly – ensuring that the covered object cannot be seen. You also have a choice of colors: black, white, and blurred. Blurred comes in handy when privacy is an issue, but determining the presence of motion is still required.

### Fiber Optic Kit

The VGA-FIBER-AN (multimode) is an analog, fiber optic conversion kit for use with 100 and 600 Series AutoDomes. This module is a video transmitter/data receiver modules designed to be mounted directly into an AutoDome power supply box.

### Ease of installation and servicing

The AutoDome 600 Series has been designed for quick and easy installation; a key feature from Bosch CCTV products. All housings feature recessed screws and latches for increased tamper resistance. AutoDome in-ceiling housings provide IP54 protection (with an optional kit) and are rated IK 8 (IEC 62262). These housings feature an impact-resistant polycarbonate rugged bubble to protect your camera from vandalism. The rugged bubble can withstand impacts equivalent to a 4.5 kg (10 lb) weight dropped from a height of 3 m (10 ft).

AutoDome pendant housings (indoor and outdoor) are rated to provide IP 66 protection and come fully assembled with a sunshield and ready for wall or pipe applications with the proper mounting hardware (purchased separately). In addition, the pendant housing comes equipped with a low-impact, high-resolution acrylic bubble for enhanced image clarity.

Outdoor Pendant housings provide an operating temperature range down to -40°C (-40°F). The optional “XT” extreme temperature kit allows an AutoDome to operate in temperatures down to -60°C (-76°F), ensuring reliable operation in even the harshest environments.

**Note:** Bosch offers a full complement of hardware and accessories (as a separate purchase) for corner, mast, roof, pipe, and in-ceiling applications, which allow the AutoDome to be easily adapted to individual site requirements.

### Easy upgrades

Bosch’s innovative software, the Configuration Tool for Imaging Devices (CTFID), allows operators or technicians to control the PTZ, change camera settings, and even update firmware from virtually anywhere without need for additional wiring.

The AutoDome 600 Series has advanced built-in diagnostics to simplify service and minimize downtime. Using the On Screen Display (OSD), a technician can quickly and easily check critical parameters (such as internal temperature and input voltage level) to verify that the dome is functioning within acceptable operating limits. If video is not present, a local inspection of three diagnostic LEDs at the camera site can identify the presence of video and control data.

### Certifications and Approvals

Electromagnetic Compatibility (EMC)	Complies with FCC Part 15, ICES-003, and CE regulations, including EN50130-4 and EN50121-4
Product Safety	Complies with CE regulations, UL, CSA, EN, and IEC Standards
Environmental	In-ceiling: IP54 (with optional VGA-IP54K-IC kit), Plenum rated Pendant: IP66, NEMA 4X
Impact Resistance	In-ceiling: IK 8

### Parts Included

#### In-ceiling

1	Fully-assembled in-ceiling housing
1	Polycarbonate bubble, clear or tinted
1	Interface box
1	Coaxial cable with ferrite

#### Indoor Pendant

1	Fully-assembled indoor pendant housing
1	Acrylic bubble, clear
1	Coaxial cable with ferrite

#### Outdoor Pendant

1	Fully-assembled outdoor pendant housing with sunshield
1	Acrylic bubble, clear
1	Coaxial cable with ferrite

#### Note:

1. Mounting hardware and accessories are available separately.
2. The coaxial cable with ferrite is required for pendant arm and in-ceiling mount applications. Do not use the coaxial cable with ferrite for pipe or roof mount applications.

## Technical Specifications

### Camera 36x Day/Night

Imager	1/4 in.-type Exview HAD CCD (progressive scan)	
Effective Picture Elements	PAL: Approx. 440,000; 752(H) x 582(V) NTSC: Approx. 380,000; 768 (H) x 494 (V)	
Lens	36x Zoom (3.4–122.4 mm) F1.6 to F4.5	
Zoom Movement Speed	NTSC	PAL
<ul style="list-style-type: none"> <li>Optical WIDE / Optical TELE – Focus Tracking ON</li> </ul>	4.0 sec.	4.0 sec.
<ul style="list-style-type: none"> <li>Optical WIDE / Optical TELE – Focus Tracking OFF</li> </ul>	2.7 sec.	2.7 sec.
<ul style="list-style-type: none"> <li>Optical WIDE / Digital TELE</li> </ul>	6.0 sec.	6.2 sec.
<ul style="list-style-type: none"> <li>Digital WIDE / Digital TELE</li> </ul>	2.1 sec.	2.3 sec.
Focus	Automatic with manual override	
Iris	Automatic with manual override	
Field of View	1.7° to 57.8°	
Video Output	1.0 Vp-p, 75 Ohm	
Gain Control	Auto/Manual/Max. (–3 dB to 28 dB, 2 dB steps)	
Aperture Correction	Horizontal and vertical	
Digital Zoom	12x	
Horizontal Resolution	550 TVL (NTSC, PAL) typical	
Synchronization	Line-Lock (–120° to 120° vertical phase adjust) or internal crystal	
<b>Sensitivity (typical)<sup>1</sup></b>	<b>30 IRE</b>	<b>50 IRE</b>
<b>Day Mode</b>		
SensUp Off	0.66 lux	1.4 lux
SensUp On (NTSC: 1/4s, 15X; PAL 1/3s, 16.7X)	0.04 lux	0.1 lux
<b>Night Mode</b>		
SensUp Off	0.104 lux	0.209 lux
SensUp On (NTSC: 1/4s, 15X; PAL 1/3s, 16.7X)	0.0052 lux	0.0103 lux
Electronic Shutter Speed	1/1 to 1/10,000 sec., 22 steps	
Signal-to-Noise Ratio (SNR)	>50 dB	

White Balance	2000 K to 10,000 K
---------------	--------------------

1. Unless otherwise stated, test conditions are: F1.6; shutter = NTSC 1/60s, PAL 1/50s; max AGC; no bubble. Clear bubble adds 0.09 f-stop loss (90% light transmission). Tinted bubble adds 0.47 f-stop loss (60% light transmission).

### Camera 28x Day/Night

Imager	1/4 in.-type Exview HAD CCD (progressive scan)	
Effective Picture Elements	NTSC: 380,000 PAL: 440,000	
Lens	28x Zoom (3.5–98.0 mm) F1.35 to F3.7	
Zoom Movement Speed	NTSC	PAL
<ul style="list-style-type: none"> <li>Optical WIDE / Optical TELE – Focus Tracking ON</li> </ul>	2.5 sec.	2.5 sec.
<ul style="list-style-type: none"> <li>Optical WIDE / Optical TELE – Focus Tracking OFF</li> </ul>	1.7 sec.	1.7 sec.
<ul style="list-style-type: none"> <li>Optical WIDE / Digital TELE – Focus Tracking ON</li> </ul>	4.5 sec.	4.9 sec.
<ul style="list-style-type: none"> <li>Optical WIDE / Digital TELE – Focus Tracking OFF</li> </ul>	1.7 sec.	1.7 sec.
<ul style="list-style-type: none"> <li>Digital WIDE / Digital TELE</li> </ul>	2.0 sec.	2.5 sec.
Focus	Automatic with manual override	
Iris	Automatic with manual override	
Field of View	2.1° to 55.8°	
Video Output	1.0 Vp-p, 75 Ohm	
Gain Control	Auto/Manual/Max. (–3 dB to 28 dB, 2 dB steps)	
Aperture Correction	Horizontal and vertical	
Digital Zoom	12x	
Horizontal Resolution	550 TVL	
Synchronization	Line-Lock (–120° to 120° vertical phase adjust) or internal crystal	
<b>Sensitivity (typical)<sup>2</sup></b>	<b>30 IRE</b>	<b>50 IRE</b>
<b>Day Mode</b>		
SensUp Off	0.33 lux	0.66 lux
SensUp On (NTSC: 1/4s, 15X; PAL 1/3s, 16.7X)	0.02 lux	0.04 lux
<b>Night Mode</b>		

SensUp Off	0.066 lux	0.166 lux
SensUp On (NTSC: 1/4s, 15X; PAL 1/3s, 16.7X)	0.0026 lux	0.0082 lux
Electronic Shutter Speed	1/1 to 1/10,000 sec., 22 steps	
Signal-to-Noise Ratio (SNR)	>50 dB	
White Balance	2000 K to 10,000 K	

2. Unless otherwise stated, test conditions are: F1.6; shutter = NTSC 1/60s, PAL 1/50s; max AGC; no bubble. Clear bubble adds 0.09 f-stop loss (90% light transmission). Tinted bubble adds 0.47 f-stop loss (60% light transmission).

### Mechanical

	In-Ceiling	Indoor Pendant	Outdoor Pendant
Pan Range	360° cont.	360° cont.	360° cont.
Tilt Angle	1° above horizon	18° above horizon	18° above horizon
Variable Speed	0.1°/s-120°/s	0.1°/s-120°/s	0.1°/s-120°/s
Pre-position Speed	Pan: 360°/s Tilt: 100°/s	Pan: 360°/s Tilt: 100°/s	Pan: 360°/s Tilt: 100°/s
Preset Accuracy	± 0.1° typ.	± 0.1° typ.	± 0.1° typ.

### Electrical

	In-Ceiling	Indoor Pendant	Outdoor Pendant
Input Voltage	21-30 VAC 50/60 Hz	21-30 VAC 50/60 Hz	21-30 VAC 50/60 Hz
Power Consumption, typical	15 W / 27 VA	15 W / 27 VA	51 W / 55 VA <sup>3</sup>

3. Add 16 W if using VG4-SHTR-XT kit.

### Surge Suppression

Protection on Video	Peak current 10 kA (Gas Tube Arrester)
Protection on Biphase	Peak current 10 A, peak power 300 W (8/20 μs)
Protection on RS-232/485	ESD protection ± 15 KV human body model
Protection on Alarm Inputs	Peak current 17 A, peak power 300 W (8/20 μs)
Protection on Alarm Outputs	Peak current 2 A, peak power 300 W (8/20 μs)
Protection on Relay Outputs	Peak current 7.3 A, peak power 600 W (10/1000 μs)

Protection on Power Input (Dome)	Peak current 7.3 A, peak power 600 W (10/1000 μs)
Protection on Power Output (Arm Power Supply)	Peak current 21.4 A, peak power 1500 W (10/1000 μs)

### Fiber Optic Kits

VGA-FIBER-AN	
Description	Multimode Fiber Optic Module
Compatible Receiver	LTC 4629 Series
Optical Fiber Compatibility	50/125 μm, 62.5/125 μm, low loss multimode glass fiber, rated for a minimum system bandwidth of 20 MHz
Max. Distance	4.0 km (2.5 miles)
Optical Budget	14 dB
Connector	One (1) ST connector
Wavelength (video/data)	850 nm / 1310 nm

### Miscellaneous

Sectors/Titling	16 independent sectors with 20-character titles/sector
Masking	24 individually configurable privacy masks
Pre-positions	99, each with 20-character titles
Camera Setup/Control	Biphase, RS-232, RS-485, Bilinx (coax)
Communications Protocols	Biphase, Bilinx, Pelco P, and Pelco D
Guard Tours	Two (2) types of tours: <ul style="list-style-type: none"> <li>Recorded tours – two (2), total duration 15 minutes</li> <li>Preset tour – one (1), consisting of up to 99 scenes, consecutively and (1) customized up to 99 scenes</li> </ul>
Supported Languages	English, Czech, Dutch, French, German, Italian, Polish, Portuguese, Russian and Spanish

### Cable Compensation

Max Distance	With Pre-comp OFF	With Pre-comp ON
RG-59/U	1000 ft (300 m)	2000 ft (600 m)
RG-6/U	1500 ft (450 m)	3000 ft (900 m)
RG-11/U	2000 ft (600 m)	4000 ft (1200 m)
Cat 5/UTP (Passive receiver)	750 ft (225 m)	1500 ft (450 m)

## User Connections

Power, Camera	21-30 VAC, 50/60 Hz
Power, Heater	21-30 VAC, 50/60 Hz
Control Data	Biphase ± RS-232 RX/TX or RS-485 ± - optional control data (dip switch selectable)
Video	BNC/UTP
Audio Line In	9 K Ohm typ, 5.5 Vp-p max

EOLR Alarm Inputs (2)	Programmable for “normally open”, “normally closed”, “normally open-supervised”, “normally closed-supervised”
Alarm Inputs (5)	Programmable for “normally open” or “normally closed”
Relay Out (1)	Dry contact output rating: 2 A @ 30 VAC
Open Collector Outputs (3)	32 VDC@150 ma max.

## Environmental

	In-Ceiling	Indoor Pendant	Outdoor Pendant
Design Rating	IP54, <sup>4</sup> Plenum rated	IP66, NEMA 4X	IP66, NEMA 4X
Operating Temp.	-10°C to 40°C (14°F to 104°F)	-10°C to 40°C (14°F to 104°F)	-40°C to 50°C (-40°F to 122°F) with XT kit: -60°C to 50°C (-76°F to 122°F)
Storage Temp.	-40°C to 60°C (-40°F to 140°F)	-40°C to 60°C (-40°F to 140°F)	-40°C to 60°C (-40°F to 140°F)
Humidity	0% to 90% relative, non-condensing	0% to 90% relative, non-condensing	0% to 100% relative, condensing

4. With optional VGA-IP54K-IC kit.

## Construction

Dimensions	See dimensional drawings
Weight	
• In-ceiling	2.66 kg (5.86 lb)
• Indoor Pendant	2.88 kg (6.3 lb)
• Outdoor Pendant	3.32 kg (7.3 lb)
Bubble Size	153.1 mm diameter (6.03 in.)
Construction Material	
• Housing	Cast aluminum

• Bubble	Pendant: Acrylic (high-resolution) In-ceiling: Polycarbonate (rugged)
Color	White (RAL 9003)
Standard Finish	Powder coated, sand finish

## Mounts/Accessories

### Bubbles

#### In-ceiling

Clear rugged polycarbonate	VGA-BUBBLE-CCLR
Tinted rugged polycarbonate	VGA-BUBBLE-CTIR

#### Pendant

Clear rugged polycarbonate	VGA-BUBBLE-PCLR
Tinted rugged polycarbonate	VGA-BUBBLE-PTIR
Clear high-resolution acrylic	VGA-BUBBLE-PCLA
Tinted high-resolution acrylic	VGA-BUBBLE-PTIA

### Pendant Arm Mounts

Wall Arm (No Transformer)	VG4-A-PA0
Wall Arm (120/230 VAC Transformer)	VG4-A-PA1 / VG4-A-PA2
Pendant Arm with Wiring	VGA-PEND-ARM
Mounting plate for VGA-PEND-ARM	VGA-PEND-WPLATE
Trim skirt for AutoDome Series Power Supplies	VG4-A-TSKIRT

### Optional Mounting Plates for Arm Mounts

Corner Mounting Plate	VG4-A-9542
Mast (Pole) Mounting Plate	VG4-A-9541

### Pendant Pipe Mounts

Pipe Mount Cap	VG4-A-9543
----------------	------------

### Pendant Roof Mounts

Roof (Parapet) Mount <small>(VG4-A-9543 Pipe Mount Cap required. Available separately.)</small>	VGA-ROOF-MOUNT
--	----------------

### Optional Mounting Plates for Roof Mounts

Flat Roof Adapter for Parapet Mount	LTC 9230/01
-------------------------------------	-------------

### In-ceiling Support Kits

Bracket for suspended or drop ceilings	VGA-IC-SP
Gasket kit for IP54 certification	VGA-IP54K-IC

### Power Supplies

Outdoor Power Supply Box, no transformer	VG4-A-PSU0
Outdoor Power Supply Box (120/230 VAC Transformer)	VG4-A-PSU1 / VG4-A-PSU2

Extended temp heater module extends temperature range to -60°C (-76°F) for outdoor pendants only	VG4-SHTR-XT
Fiber Optic Kit	VGA-FIBER-AN

**Dimensions: Indoor AutoDomes**

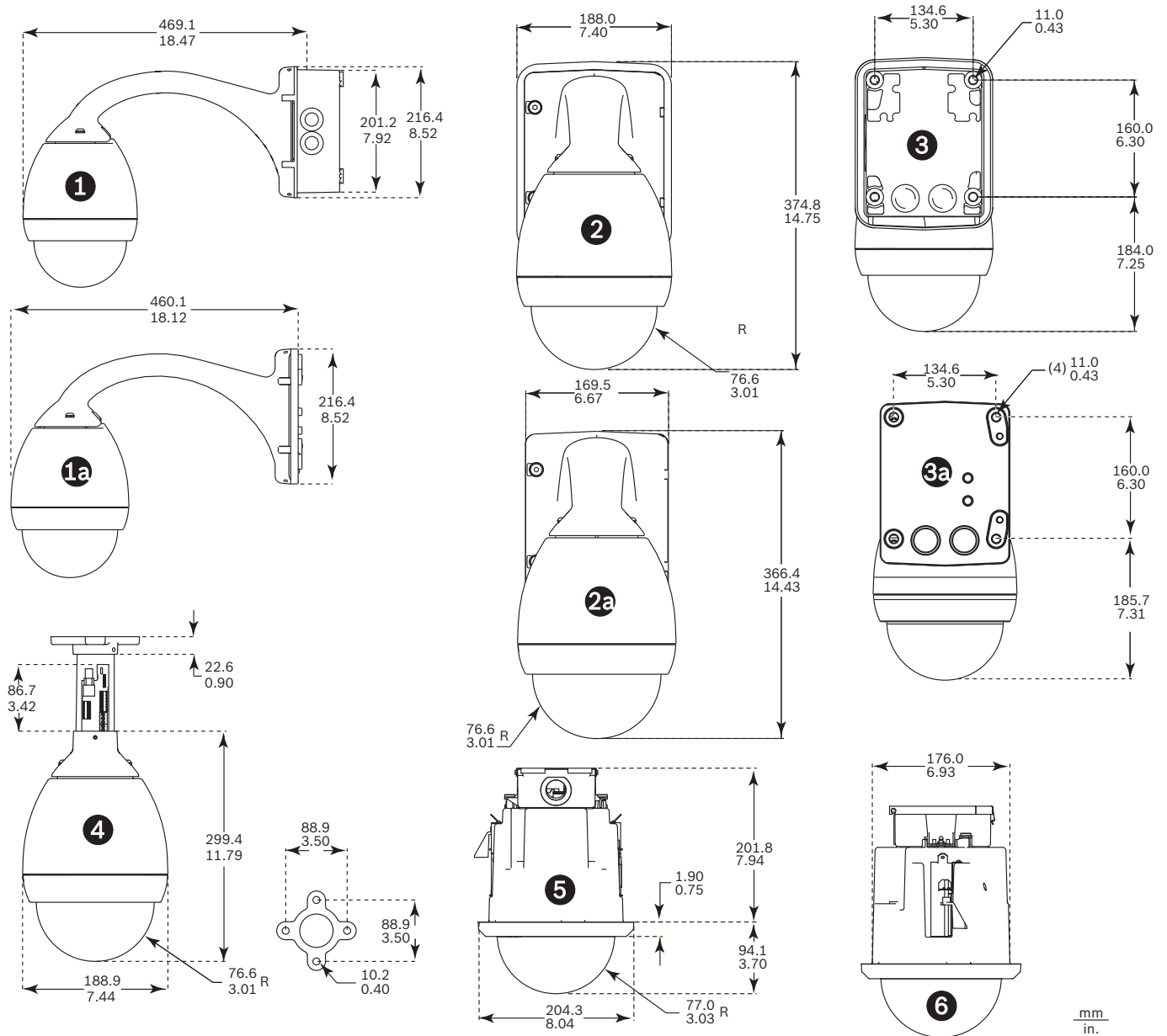

**Indoor System Dimensions**

**Reference Description**

1 Wall Mount – Side with power supply

- 1a Wall/Mast Mount – Side with VGA-PEND-WPLATE
- 2 Wall Mount – Front with power supply and trim skirt
- 2a Wall Mount – Front with power supply

- 3 Wall Mount – Back with power supply and trim skirt
- 3a Wall Mount – Back with power supply
- 4 Pipe Mount
- 5 In-ceiling Mount – Front
- 6 In-ceiling Mount – Side

**Dimensions: Outdoor AutoDomes**

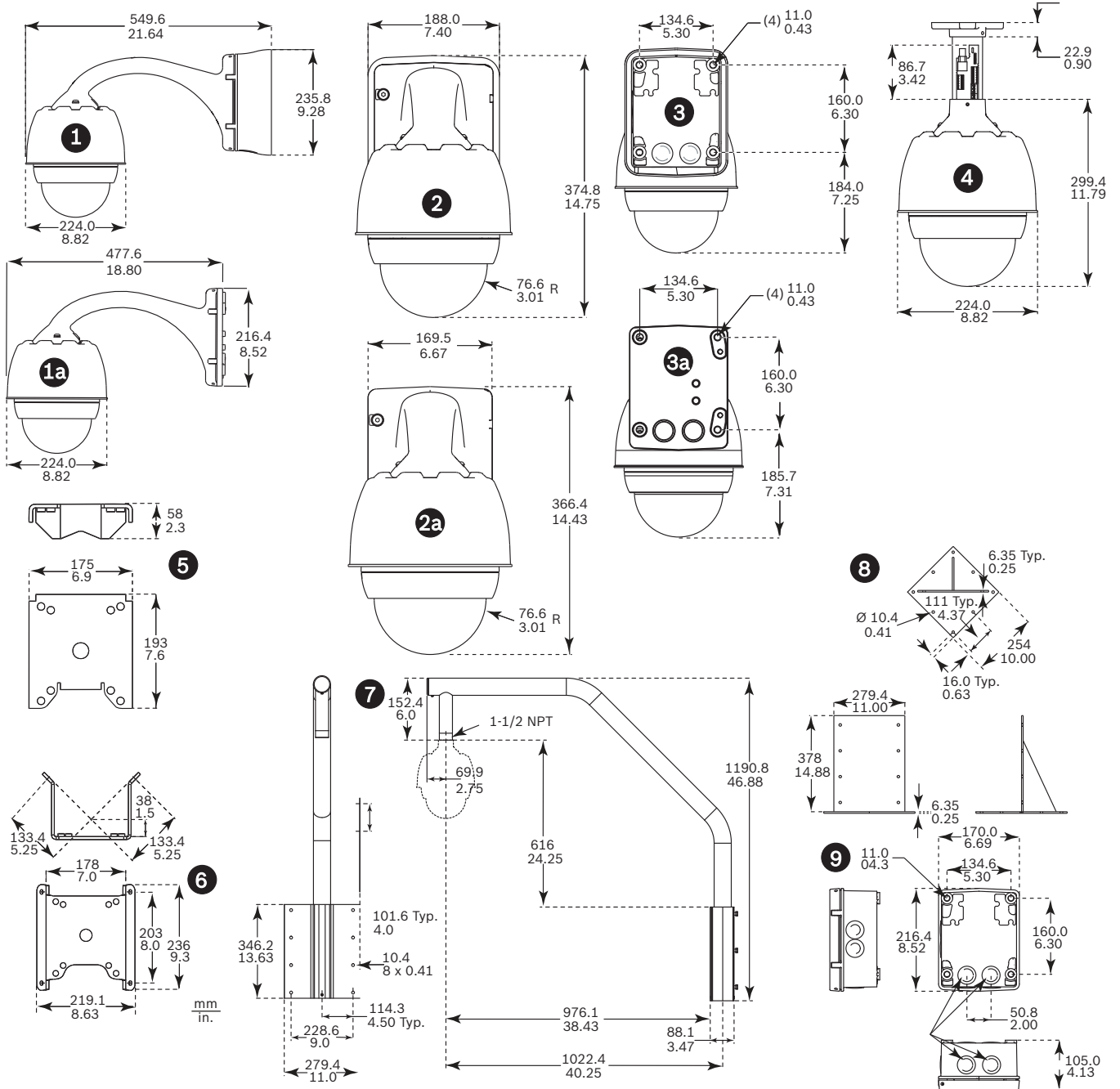

**Outdoor System Dimensions**

**Reference Description**

1 Wall Mount – Side with power supply and trim skirt

1a Wall/Mast Mount – Side with VGA-PEND-WPLATE  
 2 Wall Mount – Front with power supply and trim skirt  
 2a Wall Mount – Front with power supply



3	Wall Mount – Back with power supply and trim skirt
3a	Wall Mount – Back with power supply
4	Pipe Mount
5	Mast Mount
6	Corner Mount
7	Roof Mount
8	Roof Mount Adapter
9	Power Supply for Pipe and Roof Mounts

## Ordering Information

### **VG5-613-CCS AutoDome 600 Series 28x PAL In-ceiling Camera**

Analog 28x PAL camera, in-ceiling housing with a clear polycarbonate bubble

Order number **VG5-613-CCS**

### **VG5-623-CTS AutoDome 600 Series 28x NTSC In-ceiling Camera**

Analog 28x NTSC camera, in-ceiling housing with a tinted polycarbonate bubble

Order number **VG5-623-CTS**

### **VG5-613-ECS AutoDome 600 Series 28x PAL Outdoor Pendant Camera**

Analog 28x PAL camera, outdoor pendant housing with a clear acrylic bubble

Order number **VG5-613-ECS**

### **VG5-613-PCS AutoDome 600 Series 28x PAL Indoor Pendant Camera**

Analog 28x PAL camera, indoor pendant housing with a clear acrylic bubble

Order number **VG5-613-PCS**

### **VG5-614-ECS AutoDome 600 Series 36x PAL Outdoor Pendant Camera**

Analog 36x PAL camera, outdoor pendant housing with a clear acrylic bubble

Order number **VG5-614-ECS**

### **VG5-614-PCS AutoDome 600 Series 36x PAL Indoor Pendant Camera**

Analog 36x PAL camera, indoor pendant housing with a clear acrylic bubble

Order number **VG5-614-PCS**

### **VG5-623-ECS AutoDome 600 Series 28x NTSC Outdoor Pendant Camera**

Analog 28x NTSC camera, outdoor pendant housing with a clear acrylic bubble

Order number **VG5-623-ECS**

### **VG5-623-PCS AutoDome 600 Series 28x NTSC Indoor Pendant Camera**

Analog 28x NTSC camera, indoor pendant housing with a clear acrylic bubble

Order number **VG5-623-PCS**

### **VG5-624-ECS AutoDome 600 Series 36x NTSC Outdoor Pendant Camera**

Analog 36x NTSC camera, outdoor pendant housing with a clear acrylic bubble

Order number **VG5-624-ECS**

### **VG5-624-PCS AutoDome 600 Series 36x NTSC Indoor Pendant Camera**

Analog 36x NTSC camera, indoor pendant housing with a clear acrylic bubble

Order number **VG5-624-PCS**

## Accessories

### **VG4-A-PA0 Pendant Arm Mount**

Pendant arm mount with power supply box for a AutoDome Series cameras, no transformer, white

Order number **VG4-A-PA0**

### **VG4-A-PA1 Pendant Arm Mount with 120 VAC Transformer**

Pendant arm mount with power supply box for AutoDome Series cameras with a 120 VAC transformer, white

Order number **VG4-A-PA1**

### **VG4-A-PA2 Pendant Arm Mount with 230 VAC Transformer**

Pendant arm mount with power supply box for AutoDome Series cameras with a 230 VAC transformer, white

Order number **VG4-A-PA2**

### **VGA-PEND-ARM Pendant Arm with Wiring**

Compatible with an AutoDome Series pendant housing

Order number **VGA-PEND-ARM**

### **VGA-PEND-WPLATE Mounting Plate**

Mounting plate for VGA-PEND-ARM, compatible with an AutoDome Series camera

Order number **VGA-PEND-WPLATE**

### **VGA-ROOF-MOUNT Roof Mount**

Roof parapet mount, white

(VG4-A-9543 Pipe Mount Cap required. Available separately.)

Order number **VGA-ROOF-MOUNT**

### **LTC 9230/01 Flat Roof Mount Adapter**

For mounting a unit in an upright position on a flat surface for roof parapet mount VGA-ROOF-MOUNT

Order number **LTC 9230/01**

### **VG4-A-9541 Pole Mount Adapter**

Pole mount adapter for a for an AutoDome Series pendant arm or a VEI-30 or NEI-30 Dinion Infrared Imager, designed for poles with a diameter of 100-380 mm (4-15 in.), white

Order number **VG4-A-9541**

### **VG4-A-9542 Corner Mount Adapter**

Corner mount adapter for an AutoDome Series pendant arm or a VEI-30 or NEI-30 Dinion Infrared Imager

Order number **VG4-A-9542**

**VG4-A-9543 Pipe Mount**

Pipe mount, white, for an AutoDome Series pendant housing  
Order number **VG4-A-9543**

**VG4-IP54K-IC IP54 In-ceiling Gasket Kit for AutoDome 100/600 Series**

Gasket kit for AutoDome 100 and 600 Series AutoDome In-ceiling mounts required for IP54 environmental rating  
Order number **VG4-IP54K-IC**

**VG4-IC-SP In-ceiling Support Kit for AutoDome 100/600 Series**

Suspended ceiling support kit for AutoDome 100 and 600 Series AutoDome In-ceiling mounts  
Order number **VG4-IC-SP**

**VG4-A-PSU0 24 VAC Power Supply Unit**

24 VAC, 100 W, NEMA-rated, white, for an AutoDome Series camera  
Order number **VG4-A-PSU0**

**VG4-A-PSU1 120 VAC Power Supply Unit**

120 VAC, 100 W, NEMA-rated, white, for an AutoDome Series camera  
Order number **VG4-A-PSU1**

**VG4-A-PSU2 230 VAC Power Supply Unit**

230 VAC, 100 W, NEMA-rated, white, for an AutoDome Series camera  
Order number **VG4-A-PSU2**

**VG4-SBOX-COVER Cover for AutoDome Power Supply Boxes**

Order number **VG4-SBOX-COVER**

**VG4-FIBER-AN Analog Multimode Fiber Optic Kit**

Analog multimode video transmitter/data receiver fiber optic kit  
Order number **VG4-FIBER-AN**

**VG4-A-TSKIRT Trim Skirt for AutoDome Power Supply Boxes**

Trim skirt for the following AutoDome Series power supply boxes:  
VG4-A-PSU0F, VG4-A-PSU1, VG4-A-PSU1F, VG4-A-PSU2, VG4-A-PSU2F,  
VG4-SBOX-24VAC, VG4-SBOX-120VAC, and VG4-SBOX-230VAC  
Order number **VG4-A-TSKIRT**

**VG4-SHTR-XT Heating Module**

Extended temperature heater module extends temperature range to  $-60^{\circ}\text{C}$  ( $-76^{\circ}\text{F}$ ) for EnviroDomes and AutoDome 600 Series Outdoor Pendants only  
Order number **VG4-SHTR-XT**

**VGA-BUBBLE-CCLR Clear Rugged Bubble for an In-ceiling Housing**

Impact resistant polycarbonate bubble  
Order number **VGA-BUBBLE-CCLR**

**VGA-BUBBLE-CTIR Tinted Rugged Bubble for an In-ceiling Housing**

Impact resistant polycarbonate bubble  
Order number **VGA-BUBBLE-CTIR**

**VGA-BUBBLE-PCLR Clear Rugged Bubble for a Pendant Housing**

Impact resistant polycarbonate bubble  
Order number **VGA-BUBBLE-PCLR**

**VGA-BUBBLE-PTIR Tinted Rugged Bubble for a Pendant Housing**

Impact resistant polycarbonate bubble  
Order number **VGA-BUBBLE-PTIR**

**VGA-BUBBLE-PCLA Clear High-resolution Bubble for a Pendant Housing**

Low-impact acrylic bubble  
Order number **VGA-BUBBLE-PCLA**

**VGA-BUBBLE-PTIA Tinted High-resolution Bubble for a Pendant Housing**

Low-impact acrylic bubble  
Order number **VGA-BUBBLE-PTIA**

**VG4-MTRN-C Alternative Protocol Communications Module**

Supports the American Dynamics (AD) Manchester and the American Dynamics (AD) Sensormatic RS-422 protocols.  
Order number **VG4-MTRN-C**

**Software Options****VP-CFGSFT Configuration Tool for Imaging Devices**

Camera configuration software for use with Bilinx cameras  
Order number **VP-CFGSFT**

**Represented by:**

**Americas:**

Bosch Security Systems, Inc.  
130 Perinton Parkway  
Fairport, New York, 14450, USA  
Phone: +1 800 289 0096  
Fax: +1 585 223 9180  
security.sales@us.bosch.com  
www.boschsecurity.us

**Europe, Middle East, Africa:**

Bosch Security Systems B.V.  
P.O. Box 80002  
5600 JB Eindhoven, The Netherlands  
Phone: + 31 40 2577 284  
Fax: +31 40 2577 330  
emea.securitysystems@bosch.com  
www.boschsecurity.com

**Asia-Pacific:**

Robert Bosch (SEA) Pte Ltd, Security Systems  
11 Bishan Street 21  
Singapore 573943  
Phone: +65 6258 5511  
Fax: +65 6571 2698  
apr.securitysystems@bosch.com  
www.boschsecurity.asia