



ESL 320A/350 Series Smoke Alarms Installation Instructions

Description

ESL 320A/350 Series smoke alarms are single/multiple station photoelectric AC smoke alarms designed for use in residential occupancies including hotels, motels, and dormitories. The 320A/350 Series is compatible with existing ESL 320 Series wiring. The 320A and the 350 Series models are identical except the 350 Series provides battery backup and requires a 9-volt Duracell battery for installation.

The 320A/350 Series smoke alarms cannot be used in systems with control panels, pullstations, heat sensors, elevator recall, fire door release, etc.

Depending on the model, the 320A/350 Series smoke alarms provide the following features:

- **Tandem interconnect capability.** Allows up to 12 smoke alarms to be connected together on one circuit.
- **Self-diagnostics.** Monitors its own sensitivity. If the unit drifts out of the UL listed sensitivity range, the LED flashes rapidly.
- **Battery backup (350 Series).** Offers up to 46 hours of continuous protection in the event of a power outage.
- **Base tamper.** Discourages unauthorized removal of the smoke alarm from the base.

Installation

The smoke alarm uses a mounting base for attaching to walls and ceilings or directly to standard single-gang, 3-inch round or 4-inch octagonal electrical boxes. Contact a licensed electrician to install permanent concealed wiring.

WARNING Turn off AC power to the electrical wiring before mounting the alarm.

1. **For 350 model alarms:** Observing the correct polarity, install a 9-volt Duracell battery into the battery compartment in the back of the alarm (*Figure 1*) and slide the battery door closed.
2. If you are using the base tamper, use pliers to break off the tip of the tab located on the back of the alarm (*Figure 1*). When you use the base tamper, you must insert a screwdriver into a slot on the alarm to remove it from the base.
3. Using an NEC-approved method (see *Wiring*), attach the connector assembly provided to the appropriate building electric wiring (*Figure 2*).
4. Remove the backing from the adhesive strip (*Figure 1*) on the back of the gasket.
5. Line up the straight edges of the gasket with the lines on the back side of the mounting base and attach the gasket to the mounting base.

Figure 1. Mounting the alarm

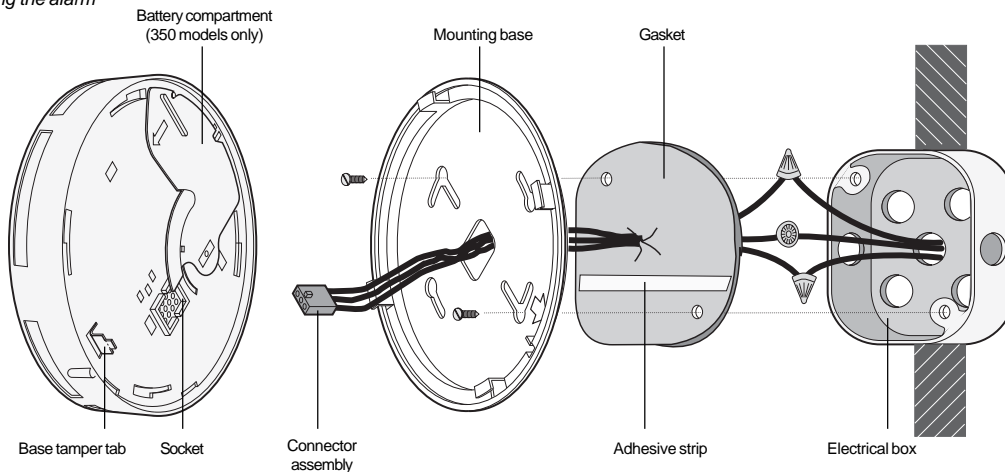
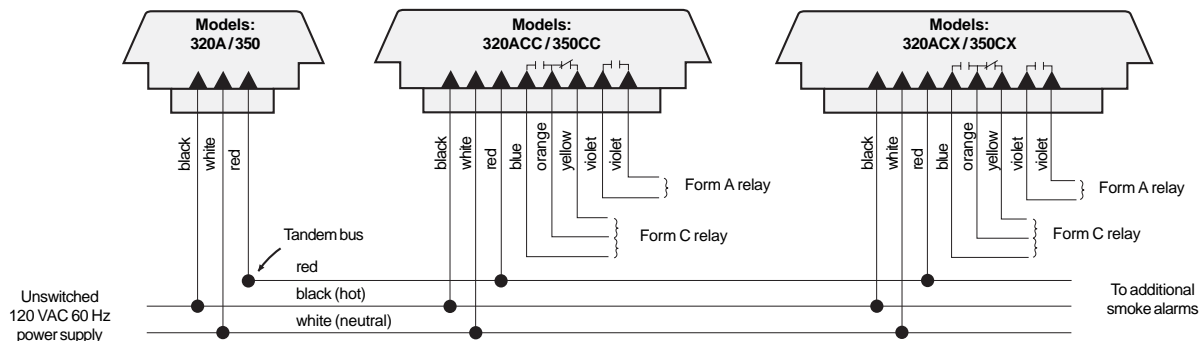
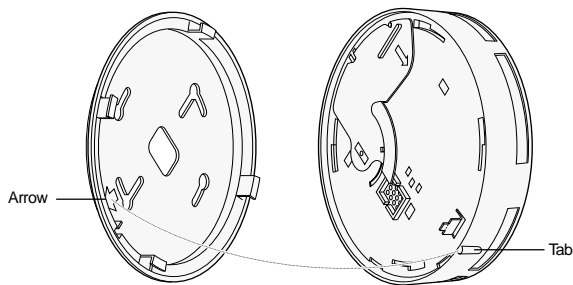

Figure 2. Wiring for tandem connections (maximum of 12)



6. Insert the connector assembly through the center hole in the mounting base and gasket (*Figure 1*) and attach the base to the mounting surface.
7. Plug the connector assembly into the socket on the back of the smoke alarm (*Figure 1*). For 350 Series units, you must install the battery and close the battery cover before the connector can be attached.
8. To attach the alarm to its mounting base, line up the arrow on the mounting base with the tab on the alarm (*Figure 3*). Insert the alarm into the base and turn clockwise approximately 15 degrees. It should snap firmly into place.

Figure 3. Arrow and tab alignment



9. Apply AC power to the alarm.
10. To test the installation, press the test/silence button (*Figure 4*) for approximately 1 second and release. The unit should go into alarm, the LED should light steadily, and the sounder should emit a temporal pattern. Testing of one alarm will also cause alarms in tandem to sound. We recommend that you test each alarm individually.
11. Smoke-test the alarm. See *Smoke test*.

Figure 4. Alarm parts

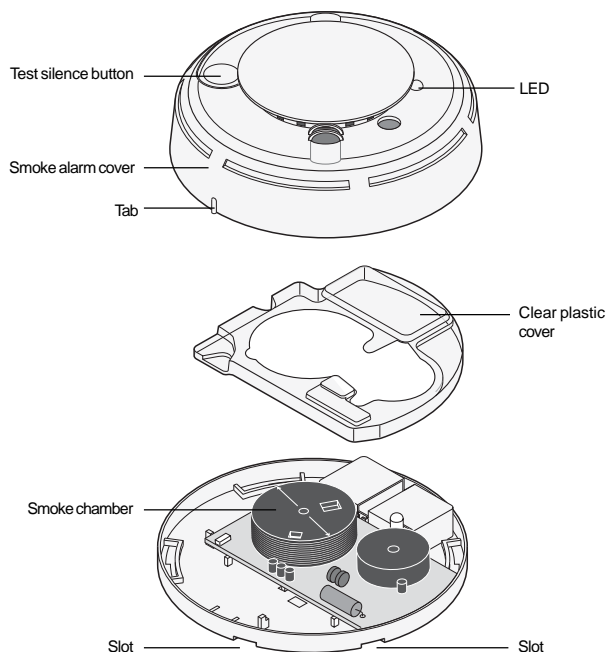

Wiring

Electrical wiring should be done by a licensed electrician. Use the following guidelines when wiring the unit:

- Observe all applicable building code requirements. Installation wiring shall conform with Article 76, Fire Protective Signaling Systems, of the National Electrical Code NFPA 70 1996 Edition. The tandem bus qualifies as a power-limited circuit.
- Use 14 AWG cable or equivalent.
- Supply AC primary power either from a dedicated branch circuit or the unswitched portion of a branch circuit also used for power and lighting.
- When replacing a 320 Series alarm with a 320A/350 Series alarm, use the existing connector.
- When replacing a 320ACX Series alarm, use the existing 320 Series connector and cap the white/red and white/blue wires. **Do not cap them together.**

Single-station installation: Cap the red wire. **Do not** connect it to any other circuit.

Tandem-station installation:

- **Do not** connect more than 12 alarms in a tandem circuit per NFPA 72.
- **Do not** exceed 5,000 ft. (1524 m) for a tandem circuit.
- Use only 320 Series and 320A/350 Series alarms in tandem connections.

Alarm test

The alarm power, sounder, and electronic module should be tested monthly as follows:

Press the test/silence button (*Figure 4*) for approximately 1 second and release. The unit should go into alarm, the LED should light steadily, and the sounder should emit a temporal pattern.

If the alarm successfully goes into alarm, the unit has power and the electronic module is functioning properly.

If the alarm fails the test, first check that power is present. If power is present and it still fails, clean the alarm and replace the smoke chamber. See *Smoke chamber replacement*.

Smoke test

Test smoke alarms in place annually using one of the following methods:

- Use *Smoke! in a can® (SM-200)*, a canned aerosol simulated smoke and follow the directions on the can; or
- Test the alarm with smoke. Hold a smoldering punk or cotton wick close to the smoke entry openings. Gently direct smoke into the alarm for 20 seconds or until an alarm is indicated.

Be sure to properly extinguish the smoke source after testing! The alarm LED should light steadily and the sounder should activate until the smoke clears or the test/silence button (*Figure 4*) is pressed.

LED status

The LED (*Figure 4*) indicates the status of the alarm as follows:

Flashing	Flashes every 6 seconds to indicate normal operation
On	Detects smoke, sending an alarm
Off	No power

When units are interconnected and one alarm activates, the LED on units sensing smoke lights steadily, and the LED on the others flashes every 4 seconds. This feature allows you to identify which alarms have detected smoke.

Test/silence button

The alarm sounder activates a temporal pattern when smoke is detected. To temporarily silence the sounder, press the test/silence button (*Figure 4*)*. The sounder resumes if smoke is still present.

* *Only the initiating alarm can be silenced and only when smoke obscuration is less than 4%/ft. During the silenced period, the LED will continue to be steady, and the sounder chirps every 4 seconds as long as smoke is present. If connected in a tandem circuit, only the smoke alarm that initiated the alarm can be silenced.*

Attach/remove the alarm

To attach the alarm to its mounting base:

1. Plug the power connector into the back of the alarm. The battery cover must be closed before the connector can be attached.
2. Line up the arrow on the mounting base with the tab on the alarm (*Figure 3*).
3. Insert the smoke alarm into the base and turn clockwise approximately 15 degrees. It should snap firmly into place.

To remove the alarm from the mounting base:

1. Grasp the alarm and turn it counterclockwise approximately 15 degrees. The alarm should snap out of the mounting base.
2. Unplug the power connector from the back of the alarm and, if applicable, remove the batteries.

To remove the alarm from the mounting base when the base tamper is used:

1. Insert a small screwdriver into the locking tab slot on the side of the base (*Figure 5*) and press in while simultaneously turning the alarm counterclockwise 15 degrees. The alarm should snap out of the mounting base.
2. Unplug the power connector from the back of the alarm and, if applicable, remove the batteries.

Figure 5. Removing the alarm cover when a base tamper is used

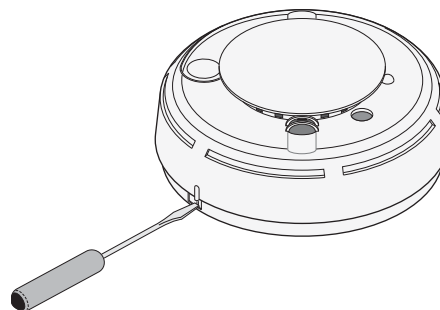

Smoke chamber replacement

To clean the smoke alarm and replace the smoke chamber (part number 211), do the following:

1. Remove the alarm from its mounting base (see *Attach/remove the alarm*). Unplug the power connector from the back of the alarm and, if applicable, remove the batteries. The alarm will activate if you remove the smoke chamber while power is applied.
2. To remove the cover from the alarm base, open the battery compartment and press the tab next to the indent (*Figure 4*). Lift the cover off and close the battery compartment.
3. Lift the clear plastic cover off the circuit board (*Figure 4*).
4. Press in on the sides of the smoke chamber (*Figure 4*) and pull it straight out and away from the alarm. Discard the smoke chamber.
5. Blow out or use a soft-bristled brush to remove dust and dirt from the smoke chamber base.
6. Line the new smoke chamber up with the smoke chamber base and snap down into place. Press firmly for proper seating. The chamber should click twice into place.
7. Replace the clear plastic cover.
8. Replace the alarm cover by sliding the tab on the cover into the two corresponding slots on the alarm base (*Figure 4*). Gently press the cover to the alarm until they snap firmly together.
9. Reattach the alarm to its mounting base. See *Attach/remove the alarm*.
10. Test the alarm. See *Alarm test* and *Smoke test*.

Maintenance

The 320A/350 Series smoke alarms are designed for easy field service and when installed and used properly, they require minimal maintenance.

Test alarms in place annually using smoke or canned aerosol simulated smoke. See *Smoke test*.

Use the following indicators to determine when routine maintenance is required:

Indicator	Maintenance required
Sounder chirping	Replace battery (see <i>Battery replacement</i>)
LED flashing rapidly	Clean the alarm and replace the smoke chamber (see <i>Smoke chamber replacement</i>)

Battery replacement

The 350 Series smoke alarms provide a battery backup which requires one 9-volt Duracell alkaline battery (provided). Battery life varies depending on how often the backup is used. The battery should be replaced yearly. If the alarm detects a low battery condition, the alarm sounds a trouble chirp every 40 seconds until the battery is replaced.

Selecting a location

Selecting a suitable location is critical to the operation of smoke alarms. This equipment should be installed in accordance with the National Fire Protection Association's (NFPA) Standard 72 (*Figure 6*).

Figure 6. Alarm location

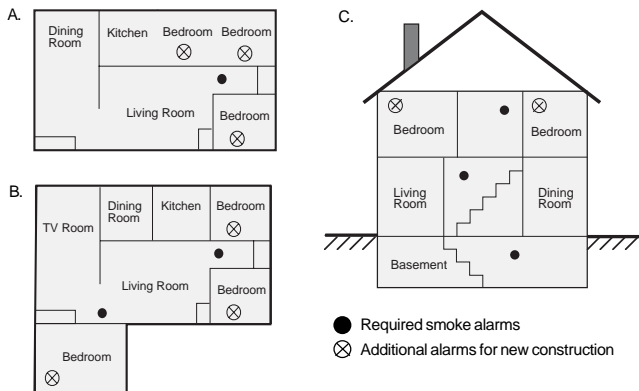

A-11-8.3.a Where to Locate the Required Smoke Alarms in Existing Construction.

The major threat from fire in a family living unit occurs at night when everyone is asleep. The principal threat to persons in sleeping areas comes from fires in the remainder of the unit. Therefore, a smoke alarm(s) is best located between the bedroom areas and the rest of the unit. In units with only one bedroom area on one floor, the smoke alarm(s) should be located as shown in Figure 6 A.

In family living units with more than one bedroom area or with more than one floor, more than one smoke alarm is required, shown in Figure 6 B.

In addition to smoke alarms outside of the sleeping areas, the installation of a smoke alarm on each additional story of the family living unit, including the basement, is required. These installations are shown in figure 6 C. The living area smoke alarm should be installed in the living room or near the stairway to the upper level, or in both locations. The basement smoke alarm should be installed in close proximity to the stairway leading to the floor above. Where installed on an open-joisted ceiling, the alarm should be placed on the bottom of the joists. The alarm should be positioned relative to the stairway to intercept smoke coming from a fire in the basement before the smoke enters the stairway.

Where to Locate the Required Smoke Alarms in New Construction.

All of the smoke alarms specified for existing construction are required and, in addition, a smoke alarm is required in each bedroom.

Are More Smoke Alarms Desirable?

The required number of smoke alarms might not provide reliable early warning protection for those areas separated by a door from the areas protected by the required smoke alarms. For this reason, it is recommended that the householder consider the use of additional smoke alarms for those areas for increased protection. The additional areas include the basement, bedrooms, dining room, furnace room, utility room, and hallways not protected by the required smoke alarms. The installation of smoke alarms in kitchens, attics (finished or unfinished), or garages is not normally recommended, as these locations occasionally experience conditions that can result in improper operation.

Regulations pertaining to smoke alarm installations vary from state to state. For more information, contact your local fire department or authority having jurisdiction (AHJ).

In addition to NFPA 72, use the following location guidelines to optimize performance and reduce the chance of false alarms:

- Locate ceiling-mounted alarms in the center of a room or hallway at least 4 inches (10cm) from any walls or partitions.
- Locate wall-mounted alarms so the top of the alarm is 4 to 12 inches (10 to 31cm) below the ceiling.
- Locate in a suitable environment as follows:
 - Temperature between 40 and 100°F (4.4 and 37.8°C)
 - Humidity between 0 and 95% noncondensing
- Locate away from air conditioners, heating registers, and any other ventilation source.
- Mount alarms on a firm permanent surface.

Smoke alarms are not to be used with detector guards unless the combination has been evaluated and found suitable for that purpose.



WARNING

Smoke alarms CANNOT provide warnings for fires resulting from explosions, smoking in bed or other furniture, ignition of flammable liquids, vapors and gases, children playing with matches or lighters. Failure to properly install, test, and maintain a smoke alarm system may cause it to fail resulting in loss of life and/or property.

Fire prevention and escape

The purpose of an early warning smoke alarm is to detect the presence of fire in its early stages and sound an alarm giving the occupants time to exit the premises safely.

Avoid Fire Hazards

No detection device can protect life in all situations. Therefore, safeguards should be taken to avoid potentially dangerous situations as follows:

- Do not smoke in bed.
- Do not leave children home alone.
- Never clean with flammable liquids such as gasoline.
- Properly store materials. A cluttered basement, attic, or other storage area is an open invitation to fire.
- Use combustible materials and electrical appliances carefully and only for their intended uses. Do not overload electrical outlets.
- Do not store explosive and/or fast burning materials in your home.
- Even after proper precautions have been taken, fires can start. Be prepared.

In Case of Fire

In the event of a fire, do the following:

- Leave immediately. Don't stop to pack or search for valuables.
- In heavy smoke, hold your breath and stay low, crawl if necessary. The clearest air is usually near the floor.
- If you have to go through a closed door, carefully feel the door and doorknob to see if undue heat is present. If they seem cool, brace your foot against the bottom of the door with your hip against the door and one hand against the top edge. Open it slightly. If you feel a rush of hot air, slam the door quickly and latch it. Unvented fire tends to build up considerable pressure. Be sure all members of the household realize and understand this danger.
- Use your neighbor's phone or a street fire alarm box to call the fire department. The job of extinguishing the fire should be left to the professionals.

Be Prepared

Practice the following steps to prepare you and your family in the event of a fire:

- Perform fire drills regularly. Use them to assure recognition of an alarm signal.
- Draw a floor plan and show two exits from each room. It is important that children be instructed carefully, because they tend to hide in times of crisis.
- Establish one meeting place outside the home. Insist that everyone meet there during an alarm to eliminate the tragedy of someone reentering the house for a missing member who is actually safe.
- If you have children and/or physically challenged people residing in your household, use window decals to help emergency personnel identify the sleeping quarters of these individuals.

Limitations of smoke alarms

The 320A/350 Series smoke alarm is designed to be connected to the electrical system of your home and requires electric power to operate. The smoke alarm will not operate and the alarm will not sound if, for any reason, the power source is cut off. In the case of an electrical fire, for example, the power source may be cut off before the alarm can function, and the alarm will not sound. If this smoke alarm is connected to a separate dedicated circuit it should work more reliably than devices connected to circuits serving other appliances, but even in dedicated circuits it can fail. It is advisable to install a battery-powered smoke alarm as a backup system. All smoke alarms should be regularly and thoroughly inspected and tested (at least once per month) to help maintain continued operability.

Smoke alarms are a significant help in reducing loss, injury and even death. However, no matter how good a detection device is, nothing works perfectly under every circumstance and we must warn you that you cannot expect a smoke alarm to ensure that you will never suffer any damage or injury.

Limited warranty

The ESL 320A/350 Series is a product of the Security business of GE Infrastructure. The manufacturer warrants this smoke alarm to be free from defects in material and workmanship under conditions of normal use for a term of 3 years from the date of manufacture.

During the warranty period, if the product or any of its components becomes defective, it will be repaired or replaced without charge.

Out-of-warranty units will be repaired at the discretion of the manufacturer, if not, a card will be forwarded to the customer suggesting a replacement unit and the cost of that unit. This warranty does not apply to units which have been subject to abuse, misuse, negligence or accident, or to which any modifications, alterations or repairs have been made or attempted. This warranty is extended only to the original purchaser of the smoke alarm and may be enforced only by such person. During the warranty period, if the alarm or any warranted components thereof becomes defective, at the manufacturer's discretion, it will be replaced or repaired without charge if returned in accordance with the following instructions:

Obtain a Return Authorization Number by calling 1-888-437-3287, then carefully pack the unit in a well padded and insulated carton and return, postal charges prepaid to:

Customer Service RMA#
GE Security
12345 SW Leveton Drive
Tualatin, OR 97062-9938

A note should be included advising the nature of the malfunction. Care must be exercised in the proper packing of alarms returned under this warranty as the manufacturer will not be responsible for warranty repairs to equipment damaged because of improper packing.

The above warranty is in lieu of all other express warranties, and implied warranties of merchantability and fitness for a particular purpose are limited in duration for a period of 3 years from the date of manufacture. Under no circumstances shall manufacturer be liable to the purchaser or any other person for incidental or consequential damages of any nature, including without limitation damages for personal injury or damages to property, and however occasioned, whether alleged as resulting from breach of warranty by manufacturer, the negligence of manufacturer or otherwise.

Manufacturer's liability will in no event exceed the purchase price of the product. Some states do not allow limitations on how long an implied warranty lasts, or the exclusion or limitations of incidental or consequential damages, so the above limitations and exclusions may not apply to you. Unless a longer period is required by applicable law, any action against Manufacturer in connection with this smoke alarm must be commenced within one year after the cause of action has occurred.

No agent, employee or representative of the Manufacturer nor any other person is authorized to modify this warranty in any respect. Repair or replacement as stated above is the exclusive remedy of the purchase hereunder. This warranty gives you specific legal rights and you also have other rights which vary from state to state.

Specifications

Voltage	120 VAC at 60 Hz
Current	130 mA max.
Sensitivity	0.83%/ft. min. to 2.46%/ft. max.
Operating temperature	40 to 100°F (0 to 55°C)
Operating humidity	0 to 95%, noncondensing
Sounder	85 dB at 10 ft. (305 cm)
Relay time delay	5 seconds (nominal)
Contacts	1 A at 30 VDC, 120 VAC resistive
Dimensions	6.0 in. (15.2 cm) diameter 2.0 in. (6.4 cm) deep
Weight	9.6 oz.
Battery	9 V alkaline Duracell, type MN1604
Listings	UL 217, CSFM, MEA

Product ordering

Product	Description
320A/350	120 VAC photoelectric alarm with pigtail connector. (350 model includes 9 V battery backup.)
320ACC/350CC	120 VAC photoelectric alarm with pigtail connector, form A and form C relays that do not operate from the tandem circuit, they must detect smoke. (350CC model includes 9 V battery backup.)
320ACX/350CX	120 VAC photoelectric alarm with pigtail connector, form A and form C relays that operate from the tandem circuit and when smoke is detected. (350CX model includes 9 V battery backup.)
Accessories	
SM-200	<i>Smoke! in a can</i> ® (canned smoke) for functional testing of smoke detectors
SM-EXT1	Extension tube for <i>Smoke! in a can</i> ®
211	Replacement smoke chambers (set of 10)

Certain items in the installation instructions are protected under one or more of the following patents: 5,546,074; 5,798,701; 5,821,666; 6,756,906.