

Model TT560

Active Transmitter for UTP Transmission

Installation and Operation Manual

Note: This installation should be made by a qualified service person and conform with local codes.



Reduce risk of fire or electrical shock. Do not expose this product to rain or moisture.

Specifications

Size	1.6"H x 4.3"W x 2.4"D (41m H x 109m W x 61m D)	Output	Low voltage current loop to receiver unit
Power Requirements	12 to 24 AC/DC 300mA 50/60Hz, Class 2	Input-Video	1.0vpp composite video Monochrome or Color

Installation

- 1) Check the twisted pair for continuity. Do this by shorting the pair of wires at one end and use an ohm meter to check the resistance at the other end. The chart below will give you the length of your wires for a measured resistance. Use a multimeter to make sure there is no voltage on the line, very high resistance to ground and an open when the short at the far end of the wires is removed. For distances greater than 6,000 feet, there are several other systems available. Contact your local Distributor or Nitek Tech Support for assistance.

Wire Gage	Distance in Feet (Meters)						
	500 (150)	1000 (300)	2000 (600)	3000 (900)	4000 (1200)	5000 (1500)	6000 (1800)
22	16	32	64	97	129	161	194
24	26	51	103	154	205	257	308
26	41	82	163	245	326	408	490

- 2) Connect video to the BNC jack of the TT560 transmitter.
- 3) Connect the twisted pair to the terminals marked "WIRE PAIR +" and "WIRE PAIR -". Note the polarity of the connection. If the wires are reversed the video will not be viewable, this will not hurt the unit. Just reverse the wires and the video will be correct. The wires must match the polarity of the wires located on the required receiver unit.
- 4) There is also an "EARTH GROUND" terminal. This connection is required for proper surge protection. If the "EARTH GROUND" is not connected the unit will be grounded through the coax shield.
- 5) Set the DIP switches on the transmitter as follows. The settings listed are for normal conditions.

Transmitter Switch Chart

DISTANCE	SWITCH POSITION			
	1	2	3	4
< 2000 ft.				
> 2000 ft.	ON			
> 4500 ft.	ON	ON		

Example

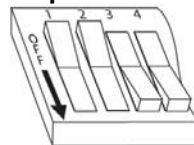

Switches 1 and 2 are in the 'OFF' position
Switches 3 and 4 are in the 'ON' position

NITEK®

USA Office:
5410 Newport Drive, Rolling Meadows, IL 60008
Phone: (800) 528-4343
Fax: (847) 259-1300
E-mail: info@nitek.net
WWW.NITEK.NET

Europe Office:
De Schans 19-21 2a, 8231 KA Lelystad
The Netherlands
Tel: +31(0)320-230005
Fax: +31(0)320-282186
E-mail: info@nitek.nl
WWW.NITEK.NL

Installation (cont'd)

6) Set the DIP switches on the receiver as follows.

Distance in feet (meters)	Switch Positions							
	1-2 and 3-4 must be set in pairs				Video Level		Video Peaking	
	1	2	3	4	5	6	7	8
>500 (150)								
>1000 (300)					ON			
>1500 (450)			ON	ON		ON		
>2000 (600)					ON		ON	
>2500 (750)			ON	ON	ON		ON	
>3000 (900)			ON	ON		ON	ON	
>3500 (1050)	ON	ON	ON	ON		ON	ON	
>4000 (1200)	ON	ON	ON	ON	ON	ON	ON	
>4500 (1350)			ON	ON	ON		ON	
>5000 (1500)			ON	ON		ON	ON	
>5500 (1650)	ON	ON	ON	ON		ON	ON	
>6000 (1800)	ON	ON	ON	ON	ON	ON	ON	

Troubleshooting

Problem

Fix/Cause

Video inverted or rolling and unstable.

- Reverse the wires of the twisted pair at either the transmitter or receiver.

Problem

Fix/Cause

No video out at the receiver.

- Check to make sure that there is video in at the transmit end.
- Make sure that the pair of wires you are using is not open or shorted between the transmit and receive points.
- Check power to the receiver. The receiver must be powered with the supplied wall pack

Problem

Fix/Cause

Ghost image at the receiver.

- Bridge tap or "T" tap on the twisted pair video line. Remove tap.

For additional help with problems please call Nitek Tech Support at (800) 528-4343. Hours are from 8am to 5pm Central Standard Time, Monday through Friday. We are always ready to help.

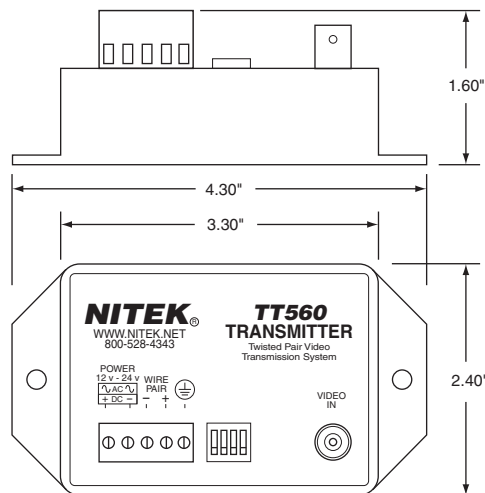

Power Requirements 12 to 24 AC/DC
300mA 60/50Hz
Class 2 only