

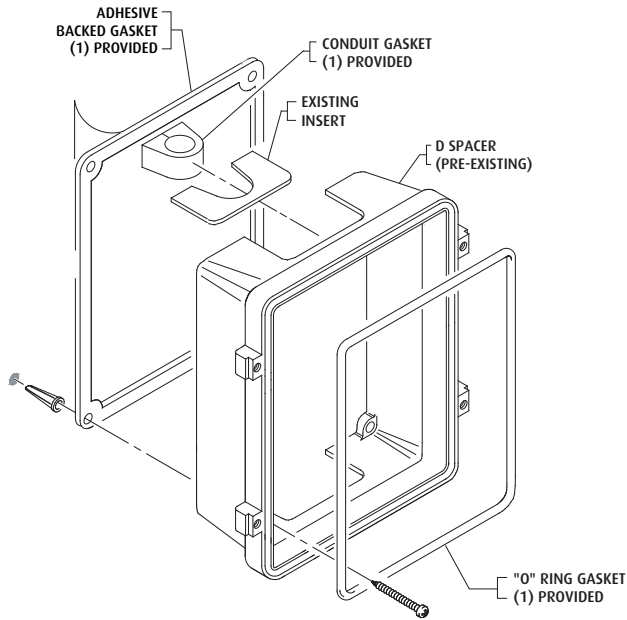

Safety Technology International, Inc.
 2306 Airport Road • Waterford, Michigan 48327-1209
 Phone: 248-673-9898 • Fax: 248-673-1246
 Toll Free: 800-888-4784 • E-mail: info@sti-usa.com
 Web: www.sti-usa.com

Safety Technology International (Europe) Ltd.
 Unit 49G Pipers Road • Park Farm Industrial Estate • Redditch
 Worcestershire • B98 0HU • England
 Tel: 44 (0) 1527 520 999 • Fax: 44 (0) 1527 501 999
 E-mail: info@sti-europe.com • Web: www.sti-europe.com



STI-1210D/1221D

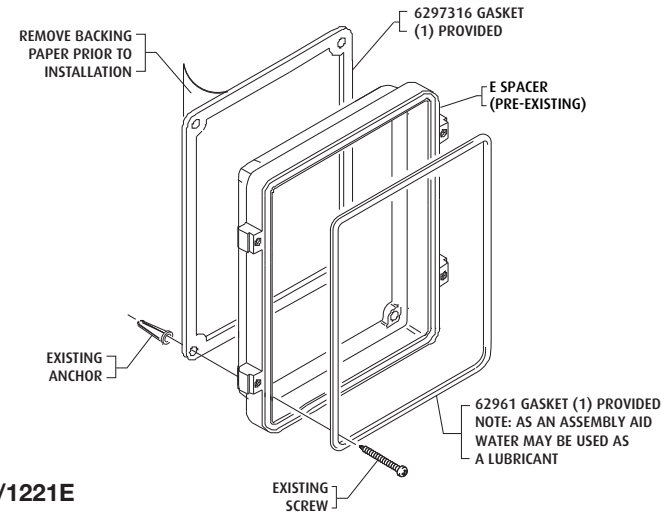

STI-1210E/1221E

! IMPORTANT

In applications where wash downs or rainfall occur, it is recommended a drain or weep hole be provided at location shown.

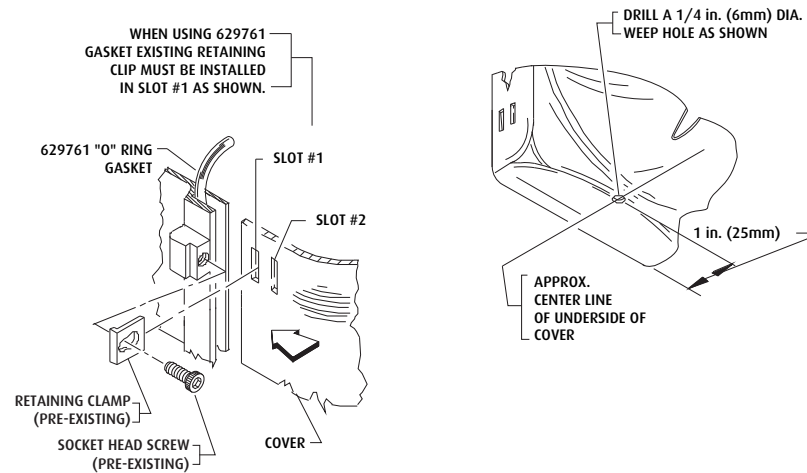

Electronic warranty form at www.sti-usa.com/wc14

INSTALLATION OF SUB-121 ENVIRO-KIT

All specifications and information shown were current as of publication and are subject to change without notice.