



SMP3CTX Series - Installation Guide

Overview:

These units convert a 115VAC or 230VAC, 50/60Hz input into a regulated 12VDC or 24VDC output up to 2.5 amp of continuous load current (*see specifications*).

SMP3CTX Series Power Supply Configuration Reference Chart:

Altronix Model Number	Accessory Power Distribution Module(s)	Number of Outputs	Fused Outputs	PTC Outputs	Individual Output Rating	Supervised	115VAC/230VAC Input Current	12VDC/24VDC Total Output Current
SMP3CTX	—	1	—	—	—	—	0.65 amp / 0.35 amp	2.5 amp
SMP3PMCTX						x	0.65 amp / 0.35 amp	2.5 amp
SMP3PMCTX						x	0.65 amp / 0.35 amp	2.5 amp
SMP3PMP4	PD4	4	x	—	3.5 amp	x	0.65 amp / 0.35 amp	2.5 amp
SMP3PMP4CB	PD4CB		—	x	2.5 amp	x	0.65 amp / 0.35 amp	2.5 amp
SMP3PMP8	PD8	8	x	—	3.5 amp	x	0.65 amp / 0.35 amp	2.5 amp
SMP3PMP8CB	PD8CB		—	x	2.5 amp	x	0.65 amp / 0.35 amp	2.5 amp
SMP3PMP16	PD16W	16	x	—	3.5 amp	x	0.65 amp / 0.35 amp	2.5 amp
SMP3PMP16CB	PD16WCB		—	x	2.5 amp	x	0.65 amp / 0.35 amp	2.5 amp

Specifications:

- Universal 115VAC/230VAC input.
- Maximum charge current 0.5 amp.
- Filtered and electronically regulated outputs.
- Built-in charger for sealed lead acid or gel type batteries.
- Automatic switch over to stand-by battery when AC fails (zero voltage drop).
- AC input and DC output LED indicators.
- Short circuit and thermal overload protection.
- Complete with power supply, power distribution module (when applicable), enclosure, cam lock & battery leads.
- Power on-off switch.

Supervised models only:

- AC fail supervision (form “C” contacts).
- Low battery supervision (form “C” contacts).

Power Supply Voltage Output Specifications:*

Output VDC	Switch Position	Max. Load DC
12VDC	SW1 - Closed (<i>Fig. 1b, pg. 3</i>)	2.5 amp
24VDC	SW1 - Open (<i>Fig. 1b, pg. 3</i>)	2.5 amp

*Specified at 25° C ambient.

Installation Instructions:

Wiring methods should be in accordance with the National Electrical Code/NFPA 70/NFPA 72/ANSI, and with all local codes and authorities having jurisdiction. Product is intended for indoor use only.

1. Mount unit in the desired location. Mark and predrill holes in the wall to line up with the top two keyholes in the enclosure. Install two upper fasteners and screws in the wall with the screw heads protruding. Place the enclosure’s upper keyholes over the two upper screws; level and secure. Mark the position of the lower two holes. Remove the enclosure. Drill the lower holes and install the three fasteners. Place the enclosure’s upper keyholes over the two upper screws. Install the two lower screws and make sure to tighten all screws (*Enclosure Dimensions, pg. 4*). Secure enclosure to earth ground.
2. Set SW1 on the power supply board to the desired DC output voltage (*Fig. 1c, pg. 3*) (*Power Supply Voltage Output Specification Chart*).
3. Connect AC power to the terminals marked [L & N], connect ground to the green flying lead (*Fig. 1, pg. 3*). Use 18 AWG or larger for all power connections (Battery, DC output). Use 22 AWG to 18 AWG for power limited circuits (AC Fail/Low Battery reporting).
4. Measure output voltage before connecting devices. This helps avoiding potential damage.

CAUTION: Do not touch exposed metal parts. Shut branch circuit power before installing or servicing equipment. There are no user serviceable parts inside. Refer installation and servicing to qualified service personnel.

5. Connect devices to be powered:
- For Power Supply Board connect to the terminals marked [- DC +].
 - For Power Distribution Module(s) connect devices to be powered to the terminal pairs 1 to 4 marked [1P & 1N] through [4P & 4N] (Fig. 2, pg. 3), 1 to 8 marked [1P & 1N] through [8P & 8N] (Fig. 3, pg. 3), or 1 to 16 marked [1P & 1N] through [16P & 16N] (Fig. 4, pg. 3), carefully observing correct polarity.
***Note:** Power switch is used to disconnect the L (HOT) terminal from the rest of the board (Fig. 1a, pg. 3).
 When servicing the unit, AC mains should be removed.
6. When using stand-by batteries, they must be lead acid or gel type. Connect battery to the terminals marked [- BAT +] (battery leads included).
12VDC operation: Use one (1) 12VDC battery.
24VDC operation: Use two (2) 12VDC batteries connected in series.
Note: When batteries are not used, a loss of AC will result in the loss of output voltage.
- For supervised models only:**
7. Connect appropriate signaling notification devices to AC Fail & Low Bat supervisory relay outputs marked [NC, C, NO] (Fig. 1b, pg. 3).

LED Diagnostics:

Red (DC)	Green (AC)	Power Supply Status
ON	ON	Normal operating condition.
ON	OFF	Loss of AC. Stand-by battery supplying power.
OFF	ON	No DC output.
OFF	OFF	Loss of AC. Discharged or no stand-by battery. No DC output.

Terminal Identification:

Power Supply Board:

Terminal Legend	Function/Description
L, G, N	Connect 115VAC/230VAC to these terminals: L to Hot, N to Neutral.
- DC +	12VDC / 24VDC @ 2.5 amp continuous output.
*AC FAIL NC, C, NO	Used to notify loss of AC power, e.g. connect to audible device or alarm panel. Relay normally energized when AC power is present. Contact rating 1 amp @ 120VAC / 28VDC.
*Low Battery NC, C, NO	Used to indicate low battery condition, e.g. connect to alarm panel. Relay normally energized when DC power is present. Contact rating 1 amp @ 120VAC / 28VDC. Low battery threshold: 12VDC output threshold set @ approximately 10.5VDC, 24VDC output threshold set @ approximately 21VDC.
- BAT +	Stand-by battery connections. Maximum charge rate 0.5 amp.

***Note:** Supervised models only

PD4/PD4CB/PD8/PD8CB/PD16W/PD16WCB - Power Distribution Module:

Terminal Legend			Function/ Description
PD4/PD4CB	PD8/PD8CB	PD16W/PD16WCB	
1P to 4P	1P to 8P	1P to 16P	Positive DC power outputs.
1N to 4N	1N to 8N	1N to 16N	Negative DC power outputs.

Fig. 1

CAUTION: De-energize unit prior to servicing. Do not expose to rain or moisture.

Switch disables power mains line voltage input.

If stand-by battery (batteries) are connected the DC output remains on.

Fig. 1a

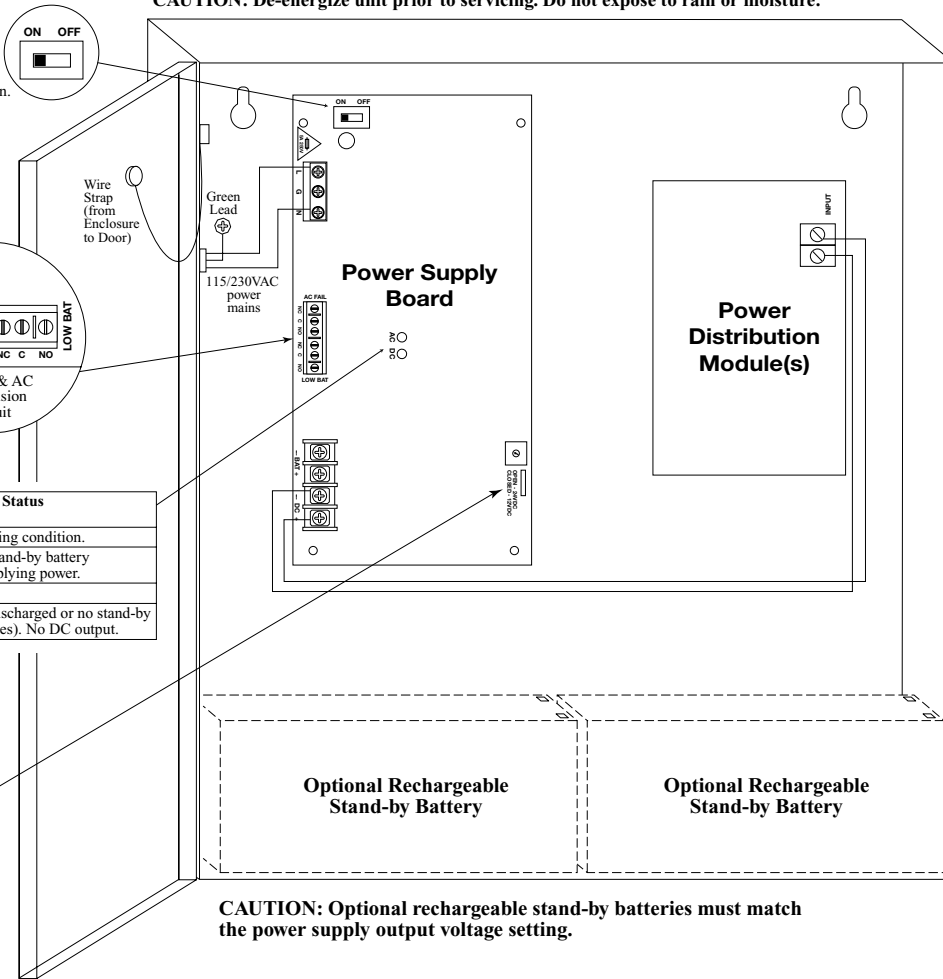
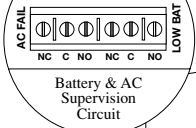

Fig. 1b



LED Diagnostics

Red (DC)	Green (AC)	Power Supply Status
ON	ON	Normal operating condition.
ON	OFF	Loss of AC. Stand-by battery (batteries) supplying power.
OFF	ON	No DC output.
OFF	OFF	Loss of AC. Discharged or no stand-by battery (batteries). No DC output.

Fig. 1c

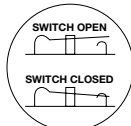

SW1
24VDC output - OPEN
12VDC output - CLOSED

CAUTION: Optional rechargeable stand-by batteries must match the power supply output voltage setting.

Power Distribution Module(s):

Fig. 2

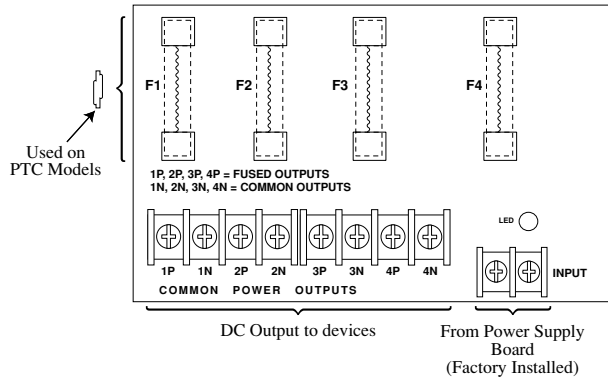

Fig. 4

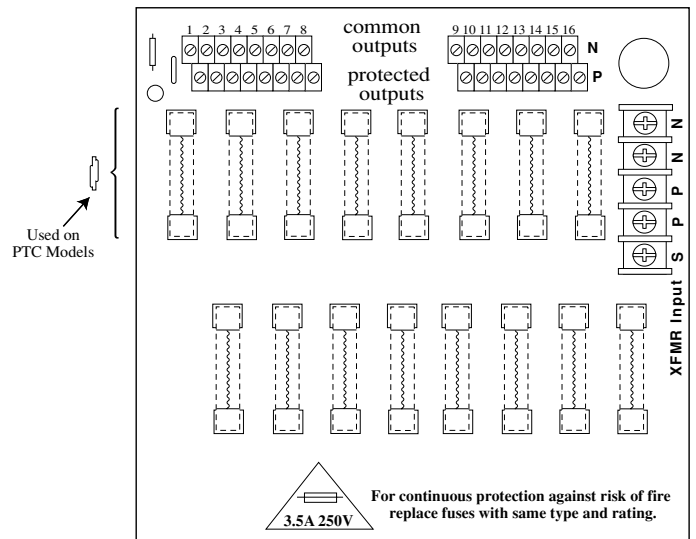
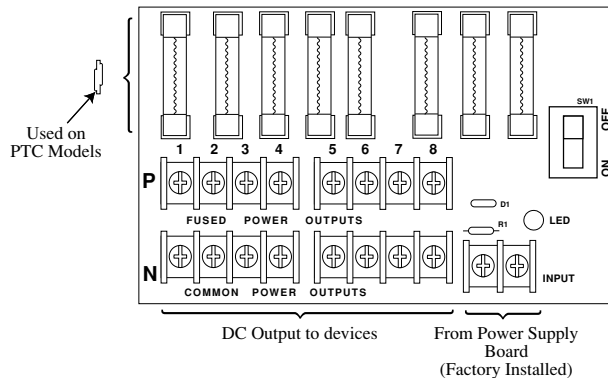
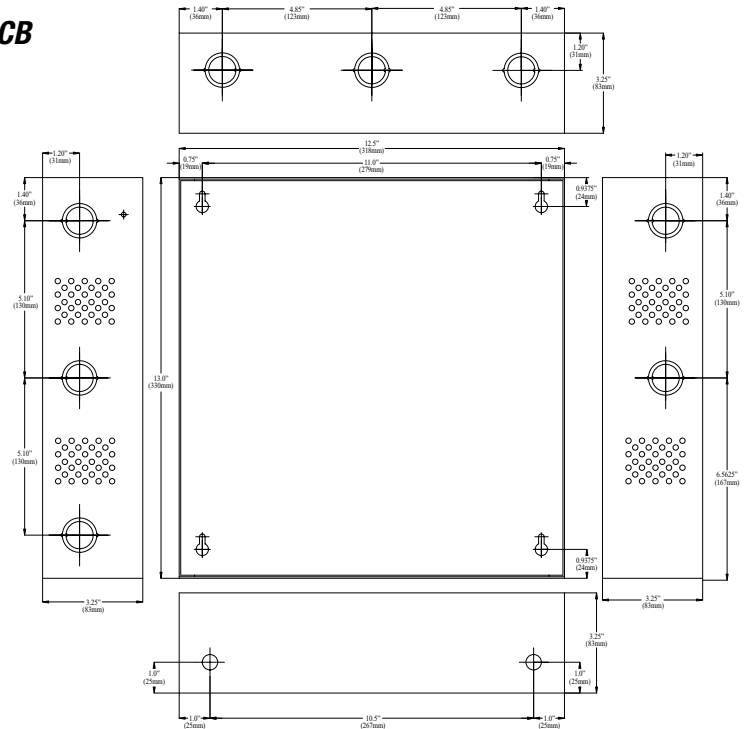

Fig. 3



Enclosure Dimensions (H x W x D approx.) (BC300):
SMP3CTX, SMP3PMCTX, SMP3PMP4, SMP3PMP4CB,
SMP3PMP8, SMP3PMP8CB, SMP3PMP16, SMP3PMP16CB
 13.5" x 13" x 3.25" (342.9mm x 330.2mm x 82.55mm)

Enclosure accommodates up to two (2) 12VDC/7AH batteries.



Enclosure Dimensions (H x W x D approx.) (BC400):
SMP3PMCTXX
 15.5" x 12" x 4.5" (393.7mm x 304.8mm x 114.3mm)

Enclosure accommodates up to two (2) 12VDC/12AH batteries.

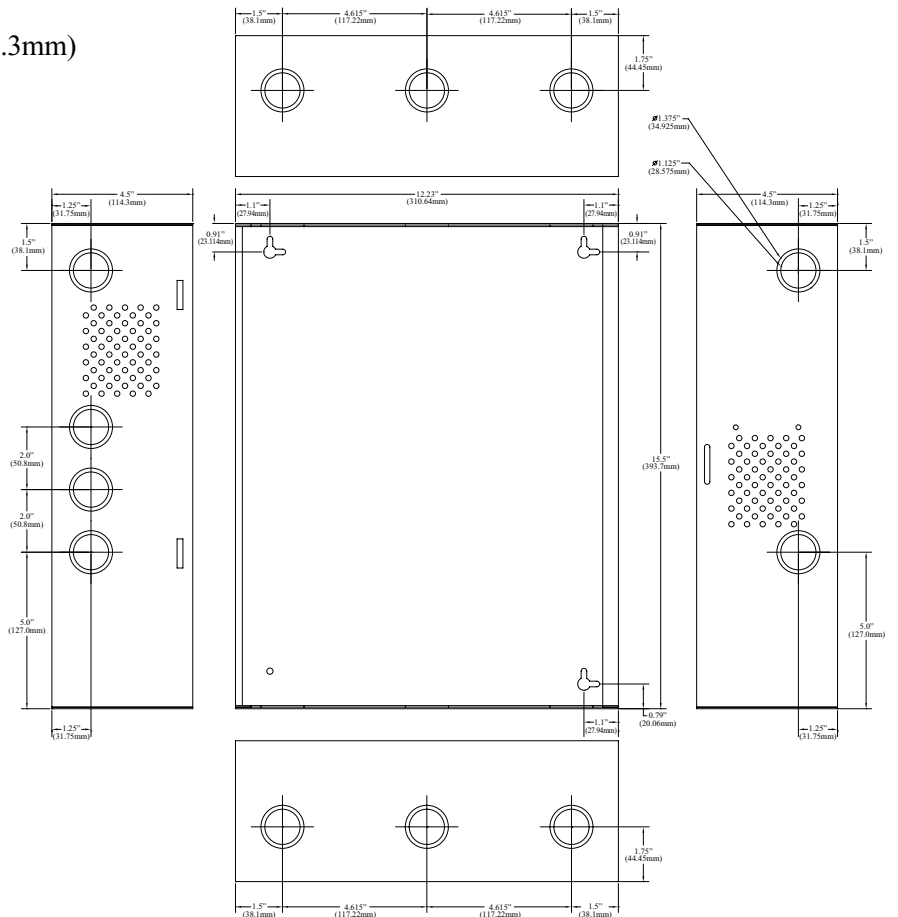

Altronix is not responsible for any typographical errors. Product specifications are subject to change without notice.

140 58th Street, Brooklyn, New York 11220 USA, 718-567-8181, fax: 718-567-9056
 web site: www.altronix.com, e-mail: info@altronix.com, Made in U.S.A.
 IISMP3CTX series - Rev. 121812

G02N

