

INSTALLATION AND MAINTENANCE INSTRUCTIONS

SMB600 Surface Mounting Kit for Use with 400 or 500 Series Detectors with 6"/152.4mm Dia. Base, 400 Series Direct-Wire Detectors and Sounder Bases



3825 Ohio Avenue, St. Charles, Illinois 60174
1-800-SENSOR2, FAX: 630-377-6495
www.systemsensor.com

General Description

The SMB600 Surface Mounting Kit allows System Sensor detectors to be surface mounted when the junction box intended to be used is not of adequate size.

The kit consists of the following parts:

Qty.	Description
1	Plastic surface mount base
2	#6 x 1" sheet metal screws
2	#8-32 x 1/2" screws
2	Plastic anchors

Junction Box Mounting Instructions

1. Read and follow the installation instructions appropriate for the detector head, or other device, to be used with the SMB600.
2. Pull the wires through the 1.3"/33mm dia. hole in the bottom of the base. The SMB600 must be mounted to a UL listed junction box (see Figure 3).
3. Using the two #8-32 screws supplied, mount the 6"/152.4mm dia. mounting base, direct wire mounting bracket, or sounder base to the surface mount base.

NOTE: When using the B402, B404, or B406 with the surface mount base, the 4 alignment ribs (see Figure 1) must be cut off flush or below the top edge of the surface mount base (see Figure 2).

4. Wire the 6"/152.4mm dia. mounting base or detector per installation instructions.

Figure 1:

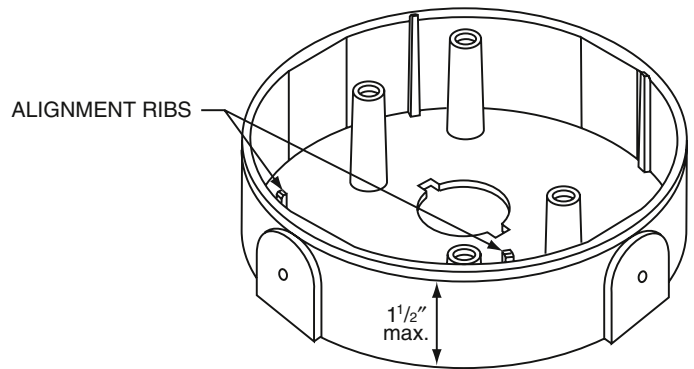

C0522-01

Figure 2:

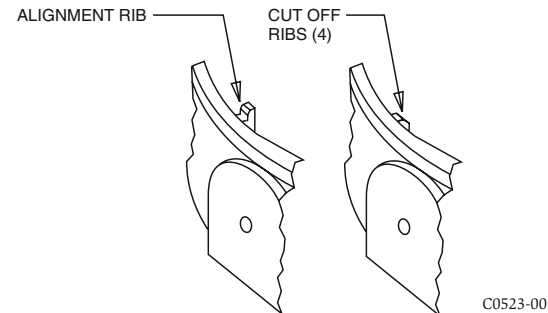

C0523-00

Figure 3:

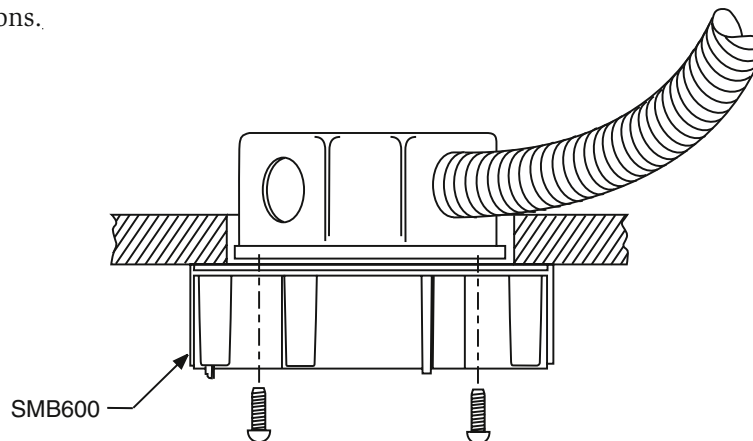

C0524-00

Surface Wiring Mounting Instructions

1. Read the installation instructions appropriate for the detector head to be used and determine the number of wires used.
 2. Drill out the appropriate holes using the drill centers provided on the sides of the adaptor (see Figure 4). Do not use conduit larger than 1/2" to connect to the SMB600.
 3. Mount the adaptor on the ceiling using the 2 keyholes and appropriate screws or bolts (not included). The screws or bolts must be long enough to go through the adaptor (5/32" or 4mm) and still fasten securely to the ceiling.
 4. Pull wiring and conduit through the drilled hole(s). Attach nut(s) (not included) to conduit fitting and tighten.
 5. Wire detector base using the instructions included with the base.
 6. Mount the base, using the supplied screws, in the SMB600 Surface Mounting Adaptor Kit.
- NOTE:** When using the B402, B404, or B406 with the surface mount base, the 4 alignment ribs (see Figure 1) must be cut off flush or below the top edge of the surface mount base (see Figure 2).
7. Plug the detector head into its mounting base and rotate clockwise.
 8. Test the system as indicated in the detector instruction manual.

Figure 4. Drill centers:

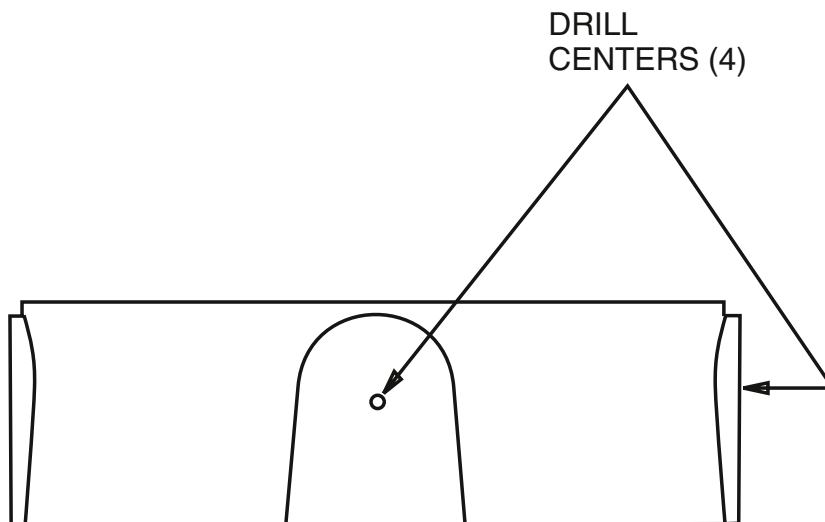

C0525-00