

Delayed Egress Timer

SA-025EQ

Features:

- 3 Relock modes to meet different installation requirements:
 - Standard manual relocking
 - BOCA (Building Officials Code Administrators) relocking
 - Timed relocking (1~60 seconds)
- Programmable nuisance delay timer (0~3 seconds)
- Adjustable pre-delay timer (1~30 seconds)
- Adjustable post-delay timer (1~60 seconds)
- Selectable manual or automatic relocking after power loss
- Lock relay output (Form C, 10A@24VDC)
- Remote alarm relay output (Form C, 10A@24VDC)
- Local alarm output (transistor ground, 500mA@12VDC)
- Door status input
- Status LEDs show relay status
- Bypass input immediately releases locks
- Free egress input allows easy egress during the delay



Dimensions:

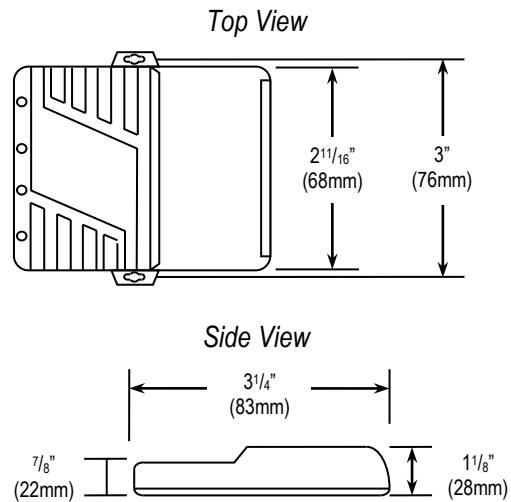

Specifications:

Operating voltage	12~24 VDC/VAC	
Current draw	Standby ¹	120mA@12VDC
	Pre-delay	90mA@12VDC
	Local alarm	35mA@12VDC
	Timer only ²	15mA@12VDC
Lock control output	10A@24VDC, Form C, NO/NC/COM	
Remote alarm output	10A@24VDC, Form C, NO/NC/COM	
Local alarm output	Transistor ground, 500mA@12VDC	

¹Lock relay and remote alarm relay are normally energized.

²When lock relay and remote alarm relay de-energized.

Also Available from SECO-LARM®:



SA-025Q
Multi-Purpose
Programmable Timer



SA-026Q
Miniature
Timer Module



SA-027WQ
7-Day
Timer



SA-027HQ
365-Day
Annual Timer

SECO-LARM® U.S.A., Inc.

16842 Millikan Avenue, Irvine, CA 92606

Phone: (949) 261-2999 | (800) 662-0800 Fax: (949) 261-7326

Website: www.seco-larm.com Email: sales@seco-larm.com



Copyright 2014 © SECO-LARM U.S.A., Inc. All rights reserved.

The SECO-LARM policy is one of continual development. For that reason, SECO-LARM reserves the right to change prices and specifications without notice. SECO-LARM is not responsible for misprints.

SECO-LARM® ENFORCER® CRIMEBUSTER® CBA SLI®