



N-1000-III/IV

Installation and Programming Manual

Notices

Fire Safety Notice: Never connect any card reader devices or locks to door, gates or barriers without first consulting the local fire codes. You must consult with and get approval of, local fire officials before installing locks or devices on any doors that may be fire exits. Use of egress push buttons may not be legal. Single action exit may be required. Always obtain proper permits and approvals in writing before installing equipment.

Notice: This equipment has been tested and found to comply with the limits for a Class A digital device, pursuant to part 15 of the FCC Rules. These limits are designed to provide reasonable protection against harmful interference when the equipment is operated in a commercial environment. This equipment generates, uses, and can radiate radio frequency energy and, if not installed and used in accordance with the instruction manual, may cause harmful interference to radio communications. Operation of this equipment in a residential area is likely to cause harmful interference in which case the user will be required to correct the interference at his own expense.

Notice: The information in this document is subject to change without notice.

Notice: This document and the data herein shall not be duplicated, used or disclosed to others for procurement or manufacturing, except as authorized with the written permission of Northern Computers, Inc. The information contained within this document or within the product itself is considered the exclusive property and trade secrets of Northern Computers, Inc. All information in this document or within the software product itself is protected by the copyright laws of the United States.

Notice: Any use of this product is subject to the terms and acceptance of the Northern Computers, Inc. "Software Agreement." Please request a copy from Northern Computers, Inc. and review this agreement carefully.

IBM is a trademark and/or a registered trademark of International Business Machines Corporation. MS-DOS, Windows, Windows NT, Windows '95, Windows '98 are trademarks and/or registered trademarks of Microsoft Corporation in the United States and/or other countries. The use of Cotag, Wiegand, IDI, Continental, NCS, Dorado, Indala, Motorola & Hayes may or may not be registered trademarks/ technologies of those respective companies.

© 2000 Northern Computers, Inc. All rights reserved.

Contents

UL Note	vi
New and Improved Features of the N-1000-III/IV	vii
Section 1: Introduction/Access Control	1-1
Section 2: System Overview	2-1
2-1: N-1000-III/IV	2-1
2-2: Programming Devices	2-2
2-3: C-100-A1 Converter	2-4
2-4: N-485-PCI-2 or HUB-2	2-4
2-5: PROM Versions	2-4
Section 3: Hardware Specifications	3-1
Section 4: Installation/Panel Layout	4-1
4-1: Four Reader Board (N-1000-IV only)	4-2
4-2: Terminal Blocks 1, 2, 3, 4	4-4
4-3: Terminal Block 5	4-6
4-4: Terminal Block 6	4-6
4-5: Terminal Block 7	4-8
4-6: Terminal Block 8	4-10
4-7: Terminal Block 9	4-10
4-8: DIP Switch Settings	4-12
4-9: Jumpers	4-14
4-10: Connectors	4-15
4-11: LEDs	4-16
4-12: Restart Button	4-18
4-13: RAM Chip	4-18
4-14: PROM Chip	4-18
4-15: Additional Installation Information	4-18
Section 5: Operation	5-1
5-1: Card Reader/Keypad Operation	5-1
5-2: Alarm Input Points	5-4
5-3: Relay Output Points	5-5
5-4: Default Input Point/Output Point Interaction	5-6
5-5: Auto-Relock Operation	5-14
5-6: Time Zone-Controlled Doors	5-14
Section 6: Wiring Requirements	6-1
6-1: Card Readers	6-1
6-2: Four Reader Board (N-1000-IV Only)	6-3
6-3: Eleven Conductor Keypads	6-5
6-4: Alarm Input Points	6-7
6-5: Relay Output Points	6-7

6-6: Communications	6-7
6-6-1: PC to C-100-A1	6-7
6-6-2: C-100-A1 to Panel(s)	6-7
6-6-3: AEP-3 to N-1000-III/IV	6-8
6-6-4: PC to N-485-PCI-2	6-12
6-6-5: N-485-PCI-2 to Panel	6-12
6-6-6: N-485-HUB-2 to Panel	6-13
6-6-7: N-485-HUB-2 to Modem	6-13
6-6-8: Bias and EOL with 485 Communication	6-14
6-7: Cable Specifications	6-18
6-8: NCI Cable Part Numbers	6-19
6-9: Configurations for RS-232 Serial Communication Ports	6-20
Section 7: Locks and Suppression	7-1
Section 8: Grounding	8-1
Section 9: Power	9-1
Appendix A: Programming Quick Reference Guide	A-1
Commands	A-5
A Command	A-5
C Command	A-6
D Command	A-8
E Command	A-9
F Command	A-10
G Command	A-12
H Command	A-13
I Command	A-13
L Command	A-14
M Command	A-15
N Command	A-16
O Command	A-17
P Command	A-18
R Command	A-18
T Command	A-19
V Command	A-19
W Command (Used with the N-1000-III/IV only)	A-20
Z Command	A-21
OR'ing of Inputs	A-21
Output Groups by Readers	A-22
Appendix B: N-1000-III/IV Compared to N-1000-II	B-1
Appendix C: Troubleshooting	C-1
N1000-III/IV Self-Test Capability	C-3
Index	C-1

Preface

The N-1000-III/IV Installation Manual provides all information necessary for installation of N-1000-III, N-1000-III-X, N-1000-IV, and N-1000-IV-X control panels.

All of the N-1000-III/IV versions have both the 20 mA and 485 multi-drop communications interfaces.

The N-1000-III/IV can be used in existing N-1000-II/N-800 systems provided the existing panels have version 8.0 or higher firmware.

Note: When the N-1000-II/N-800 is configured for 485 (N-485-API-x), the firmware version must match the 485 version in the N-1000-III/IV.

The following table identifies the different features of each version of the N-1000 panel:

Version*	Card Readers	Matrix Keypads	Alarm Inputs**	Relay Outputs	Cards***	Buffers***
N-1000-III	2	2	16	4	5,000	10,200
N-1000-III-X	2	2	16	8	25,000	6,600
N-1000-IV	4	2	16	4	5,000	10,200
N-1000-IV-X	4	2	16	8	25,000	6,600

* A version with removable wiring terminal strips is available for each model and is designated by an *R* after the version number.

**Two system alarms are independent of the sixteen zone inputs. Matrix keypads do not use any of the 16 alarm inputs.

***These are default values. Capacity can be changed by use of the I command U option. Refer to *Appendix A: Programming Quick Reference Guide* for details.

UL Note

The N-1000-III/IV panel's alarm point monitoring only monitors the door position (UL294). It is **not** intended as a proprietary burglar alarm (UL1094).

The control panel was UL294 tested as a stand alone unit only.

The N-485-HUB-2 was not investigated by UL.

The N-1000-III/IV was UL294 tested using the following card readers:

- Model 30387 (CR-1) Wiegand swipe reader.
- Model 5365BGP00 (PR-MINI-PROX) proximity reader.
- Model 5355AGN00 (PR-P-PRO) proximity reader.

The N-1000-III/IV was UL294 tested using the Basler Electric transformer part number BE11625CAA-0042 (X-4).

New and Improved Features of the N-1000-III/IV

The N-1000-III/IV series panels have both a number of improvements and some unique features as compared to the N-1000-II control panels. Some of these features are highlighted below. For a more detailed description refer to *Appendix B* of this manual.

- Four layer PWB and other improvements provide greater electrical noise immunity.
- High efficiency switching regulators result in reduced heat generation and extended backup battery operation.
- A Four Reader Board allows the N-1000-IV panel to support a total of four readers. (See *Section 4-3* for details.) When this board is present **all four readers attach to it** via its removable terminal strips. A Reader Function Test is available on the Four Reader Board by shorting a pair of jumper prongs labeled *TEST*. This will cause the board to generate a simulated card read from each of the four readers.
- An improved canister has more knockouts, a larger battery bracket and improved wiring space, since the board is centered in the enclosure. (The old enclosure can be field retrofitted for the new board.)
- The processor speed is substantially faster than the standard N-1000-II, increasing the speed of internal processing. At the same time, communications output is the same as the N-1000-II panels so they can be used in the same loop.
- An additional Terminal Block (TB9) has been added in the upper left quadrant of the board. This terminal block has an Earth Ground connection; a battery plus and minus (in addition to the soldered-in battery wires); AC connections 1 and 2 (there are no spade lugs for AC or battery); the Tamper and External Power Status inputs with common posts; and a place to tie the RS-485 shields.
- The N-1000-III/IV firmware (version 08.01.29 or later) has a built-in test capability that can be used to check the functioning of most of the circuit board's hardware. This feature is detailed in *Appendix C: Trouble Shooting*.
- There are both RS-485 and RS-232 communications ports in addition to the 20 milliamp port. The RS-485 port is selected by a change of Jumper 1 in lieu of the 20 milliamp. The RS-232 port can be used in addition to or instead of the other ports.
- A 16.5 volt AC power source is now required, allowing the charging of a 12 volt battery for back-up as well as the supply of 12 volt reader and PIR egress power from the N-1000-III/IV.
- A 12 volt, 500 mA output is available for powering 12 volt readers or PIR egress detectors. Connections for this are at TB9 terminals 7 (+) and 8 (Common).

- Detection of a primary power failure by either the internal sensor or the input from the relay on the external supply will generate an Alarm 19 not Alarm 8. Alarm Point 8 is now available for use as a standard alarm point
- Automatically resetting solid state fuses are used.
- The Green Low-V OK LED will go off to indicate low 12 Volt battery (indicator turns off at approximately 10.1 volts, the panel shuts down at approximately 9.9 volts) or disconnected RAM back-up (JP9 removed).
- A special set of connectors for the AEP-3 Relay Expansion board is provided. J1 is a connector for the present AEP-3 Board design. J2 is a double connector and will be used for a future development.
- There are screw terminals for the reader cable shield connections. These are nearer to where the wires come in, eliminating the need to run the shield wire around the board.
- The terminals on Terminal Block 8 are used exclusively for 11 wire Keypads. This makes all regular inputs available even when a keypad is used. The K option is no longer needed. The P option must still be entered for use with PINs. Screw Terminal 4 is used for the Black (Ground) wire of the Keypad.
- There is a separate Tamper Input located on TB9. This makes Input 12 (terminal now located on TB6) available as a regular alarm input.
- Each input can be individually programmed for both *Normally Open* or *Normally Closed* and *Supervised* or *Non-Supervised* operation.
- There are several changes to the *System* inputs.
 - Alarm 17 Communications status alarm, but now it reports for either 20 mA or 485 failures.
 - Alarm 18 Reserved for future reporting of an Auxiliary Communications Status (the RS-232 port.)
 - Alarm 19 Primary Power Fail alarm.
 - Alarm 20 Tamper alarm (with special terminal connections on Terminal Block 9).
 - Alarm 21 Input Ground Fault alarm. If the input is shorted to Earth Ground this alarm will be generated. (Some fault conditions may generate an ALARM rather than TROUBLE from the point, but *no ground fault will be interpreted as NORMAL.*)
 - Alarm 22 Reserved for future use.
 - Alarm 23 Indicates an external 5 volt reader power short circuit.
 - Alarm 99 Generated at restart either due to the Push Button or the watch dog timer. (This alarm cannot be stored in the history buffer.) A 99 trouble is communicated on a cold boot-up reset when the RAM memory is being initialized.
- Relays are heavy duty inductive load rated. They have a maximum load rating of 30 VDC, 5 A Resistive, 2 A Inductive. They also have circuitry which is less susceptible to electrical switching noise.

INTRODUCTION

Section 1: Access Control

Access control is computerized control over entry to any area that can be secured with a lock and key. Entry is only allowed to authorized people at authorized times. Control of who is allowed to come and go is easily maintained.

The weakness of a lock and key security system is the common key. The key is a readily duplicated piece of metal that gives anyone who holds it access to an area. The risk of lost or stolen keys, with the expense of changing locks, is a costly problem. Access control is an effective and affordable solution to this problem. With access control, each person receives a card or keycode which restricts access to authorized areas at authorized times. A small, programmable control panel allows or denies access. If a card is lost or stolen, or if a keycode is no longer secure, the control panel can be reprogrammed quickly and easily.

An additional benefit of access control is report capability. The system provides reports of all card/keycode activity, including whether access was granted or denied, and why. A permanent record of all entries to an area can be maintained.

Section 2: System Overview

2-1: N-1000-III/IV

The N-1000-III/IV control panels are the decision-making units in the access control system. Each control panel contains a *central processing unit* (CPU) and memory for local control capability. Control panel database information is programmed from a central programming device (computer, printer/programmer or data terminal). The panels then operate independently from the programming device. In this distributed database system, the programming device need not be on-line for system operation.

The control panels interface to the programming device via the C-100-A1 20 mA Current Loop Converter or via the 485 multi-drop interfaces (N-485-PCI-2 or N-485-HUB-2). A single communications loop supports up to 63 uniquely addressed control panels if the 20 mA loop is utilized or 31 panels for 485 communications. A typical 20 mA communications loop configuration is shown in Figure 2-1, while Figure 2-2 illustrates a typical 485 multi-drop configuration.

The N-1000-III control panel provides 16 points for alarm monitoring and four output control relays. The N-1000-III-X control panel includes four additional relays (providing a total of eight) and has expanded database/buffer memory capacity. The N-1000-IV version has four rather than two card readers and four output control relays. The N-1000-IV-X control panel includes four additional relays (providing a total of eight) with expanded database/buffer memory capacity. The

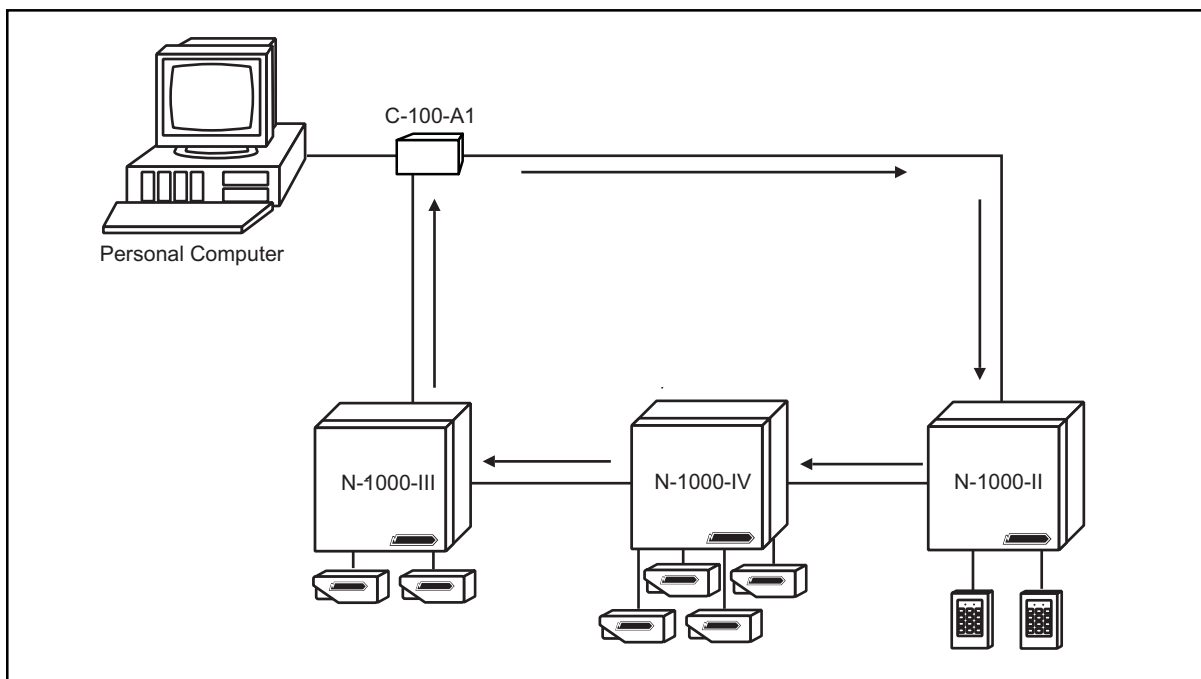

Figure 2-1. **Typical 20 mA Communications Loop.** The N-1000 control panels can be in any order in the loop or dropline as long as each has a unique address.

N-1000-III-X is shown in Figure 2-3 with enclosure and battery. Figure 2-4 shows the N-1000-IV-X with Four Reader Board, battery and enclosure.

The minimum configuration for the N-1000-III/IV includes the control panel, power transformer, reader and communication converter.

Control panels can operate in a buffered mode in which system transactions are stored in transaction buffer memory at the panels rather than transmitted to the programming device. Every transaction (input point change of state, code use) uses one location in buffer memory. The buffered information can later be transmitted to the programming device.

The N-1000-III/IV firmware (version 08.01.29 or later) has a built-in test capability that can be used to check the functioning of most of the circuit board's hardware. Refer to *Appendix C: Troubling Shooting* for details.

2-2: Programming Devices

N-1000-III/IV control panels in a communications loop are programmed with a personal computer, printer/programmer or data terminal.

When using a personal computer as the system programming device, the PC software serves as a database manager for the N-1000-III/IV control panels. Information is entered into the PC databases and then downloaded to the control panels. During the download procedure, the PC software converts the database information at the disk level to a series of command strings from the N-1000 instruction set. The commands are then sent to the appropriate control panels. The panels then operate independently from the computer. The advantages of using a computer as the system programming device include ease of programming and operation, permanent disk storage of all database information and extensive report options.

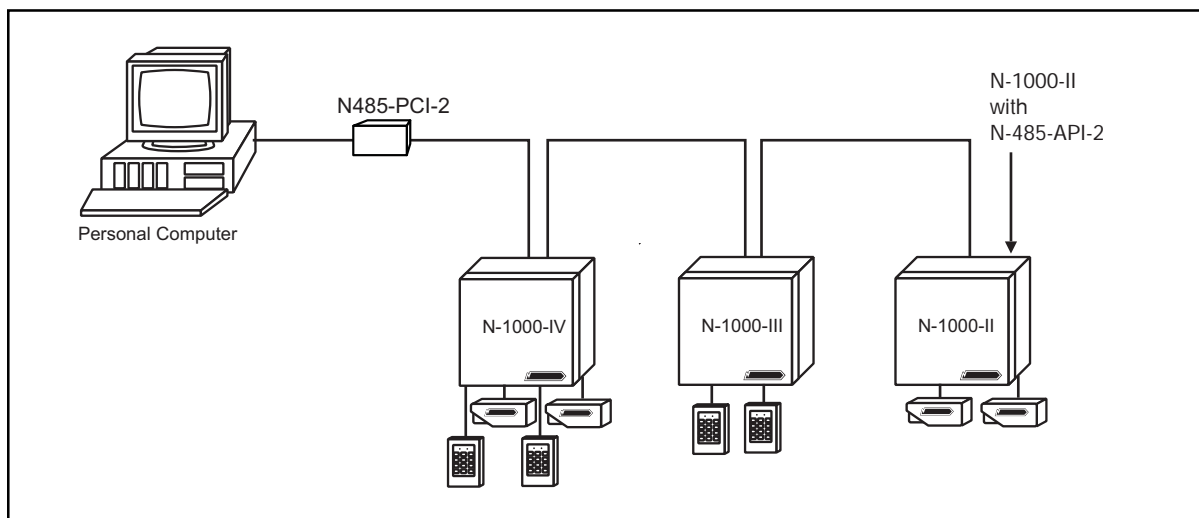

Figure 2-2. **Typical 485-Multidrop Configuration.** The N-1000-III/IV can be used in existing N-1000-II/N-800 systems provided the existing panels have version 8.0 or higher firmware. When the N-1000-II/N-800 is configured for 485 (N-485-API-2) as in this example, the firmware version must match the 485 version in the N-1000-III/IV.

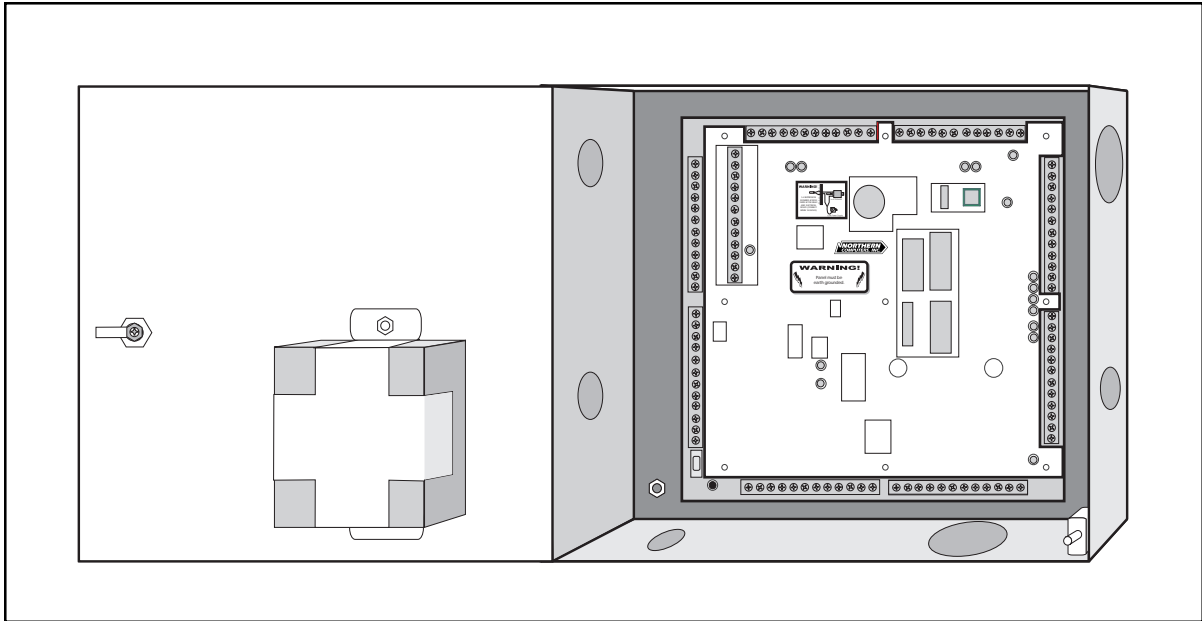

Figure 2-3. **N-1000-III-X Panel with Enclosure.** The N-1000-III control panel provides 16 alarm points for alarm monitoring capability and four relays for output control capability. The N-1000-III-X includes four additional relays (providing a total of eight) and has expanded database/buffer memory capacity.

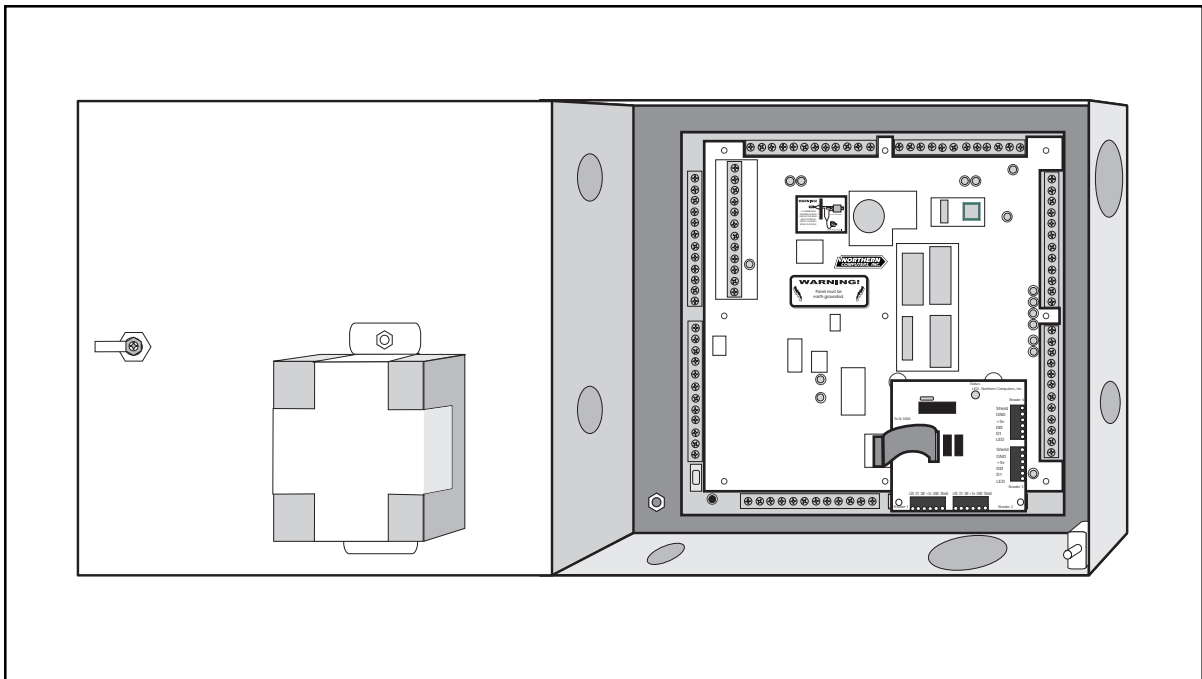

Figure 2-4. **N-1000-IV-X Panel with Enclosure.** The N-1000-IV supports four card readers and four relays for output control capability. The N-1000-IV-X includes four additional relays with expanded database/buffer memory capacity.

When using a printer/programmer or data terminal as the system programming device, all command strings are sent manually to the control panels by the operator. Printer/programmer and data terminal programming provide no safeguard against lost database memory at the panel level.

2-3: C-100-A1 Converter

The C-100-A1 Converter serves as the interface between the programming device and the N-1000 control panels. The C-100-A1 allows the programming device, using RS-232 port, to communicate with the control panels in a 20 mA current loop. The C-100-A1 can be configured for use as a C-100-C, C-100-T or C-100-M, determined by the position of six DIP switches on the RS-232 connector. These configurations are used as follows:

- computer to local control panels C-100-C
- printer/programmer to local control panels C-100-T
- computer to remote control panels via modem C-100-M

Refer to the *C-100-A1 Manual* for further details.

2-4: N-485-PCI-2 or HUB-2

The N-485-PCI-2 is used to interface between a PC's RS-232 port and the 485 multi-drop communications bus. The N-485-HUB-2 is used to interface between a modem's RS-232 port and the 485 multi-drop bus. Only the "-2" versions of these products will function with the N-1000-III/IV.

2-5: PROM Versions

The N-1000-III/IV PROM (Programmable Read Only Memory) chips provide permanent storage for the program and control logic information necessary to coordinate and drive the system hardware. The PROM chip is also referred to as the control panel's **FIRMWARE**.

The PROM version in use determines the commands and programming features available for use with the control panel. Operations such as alarm point programming, site code checking, card/ keycode capacity, transaction buffer capacity, Visitor and Limited Use status cards and local anti-passback are all functions of the PROM version in use. Specific command string syntax and the availability of advanced programming commands are also dependent upon the PROM version.

Refer to the command summary in *Appendix A* of this manual. Or contact NCI for additional information on PROM versions.

Section 3: Hardware Specifications

Power Requirements:

The N-1000-III/IV requires a 16.5 VAC, 50 VA, 60 HZ or 12 VDC linear (2 amp continuous) power supply.

Output Power:

12 VDC (10 to 14 volts) 500 mA for readers requiring 12 VDC or motion detector devices (not for use with locking devices). A 5 volt 500 mA output is available for standard 5 VDC reader requirements.

Battery Backup:

The 12 VDC (4 amp/hr.) battery provides up to four hours of full operational backup (depending on the load and the age of the battery). To maintain the maximum back-up time, replace the battery every four years or every two years if operating at higher temperatures.

Battery Current Draw:

Control panel	300 mA		300 mA
Alarm points	5 mA each	(x 18)	90 mA
Relays activated	50 mA each	(x 8)	400 mA
12 V & readers	500 mA maximum		500 mA
5 V card readers	500 mA maximum		500 mA
<hr/>			
Total	1.8 amps maximum		1.79 amps

Memory Backup:

A large value capacitor retains panel memory upon loss of both primary and backup battery power for up to seven days (depending on ambient temperature and the number of RAM ICs).

Fuses:

3 amp solid-state, non-replaceable, automatic resetting. Depending on the overload, and the temperature, it may take up to several minutes for the fuses to reset.

Alarm Input Points:

Input points are provided which can be configured for either normally open or normally closed and either 3 state supervised or unsupervised. Separate non-supervised inputs are provided for an optional external primary power fail indication and the standard enclosure tamper switch.

Relay Output Points:

Four double pole, double throw (DPDT) relay contacts with both normally-open and normally-closed sides, rated for 30 VDC 2 amp inductive loads. The N-1000-III/IV-X controllers provide four additional relays (eight total). These relays can also be utilized in dry circuit applications (e.g., mechanical shunts, data interruptions, etc.). NOTE: once the relay pole has been used on an inductive load (door strikes, magnetic locks, etc.) it cannot be used in low current dry circuit applications. Northern recommends using the "A" pole of the relays for inductive loads and the "B" pole for dry circuit (logic) loads.

Operating Temperature:
35° to 110° F (2° to 43° C)

Operating Relative Humidity:
Up to 85% non-condensing.

Enclosure:
14" H x 16" W x 4" D (35.6 cm x 40.6 cm x 10.2 cm) with knockouts, hinged cover with lock and key. Enclosure tamper switch provided. The N-1000-III/IV enclosure (with control panel) is illustrated in Figure 3-1.

Weight:
21 pounds (9.5 kg) with enclosure and backup battery.

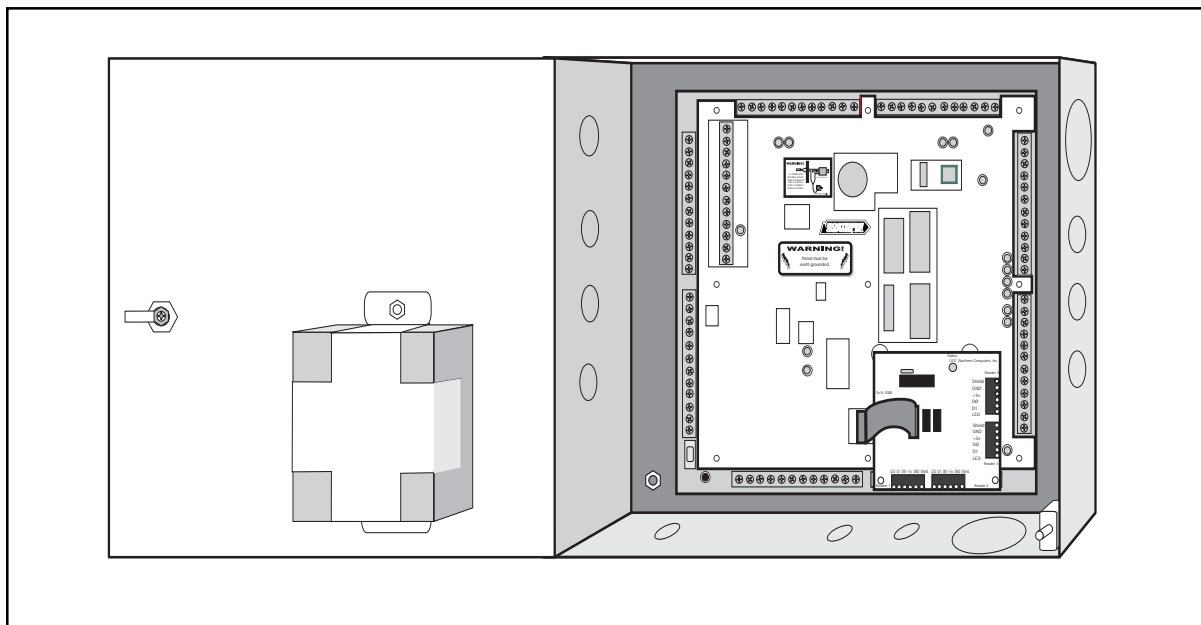

Figure 3-1. **Enclosure for the N-1000-III/IV.** The N-1000 enclosure, shown here with the N-1000-IV panel, has a lock and key, knockouts and a tamper switch. A 12 VDC battery is mounted on the door.

INSTALLATION

Section 4: Panel Layout

The N-1000-III-X has nine screw-down terminal blocks. Each terminal block, in turn, has 12 individual terminal positions, described in the following sections. Figure 4-1 shows the panel with its printed template. The N-1000-IV-X has an additional board in place of TB5 (see Figure 4-2) with four removable wiring terminal blocks for connection to four readers. Complete terminal block details follow.

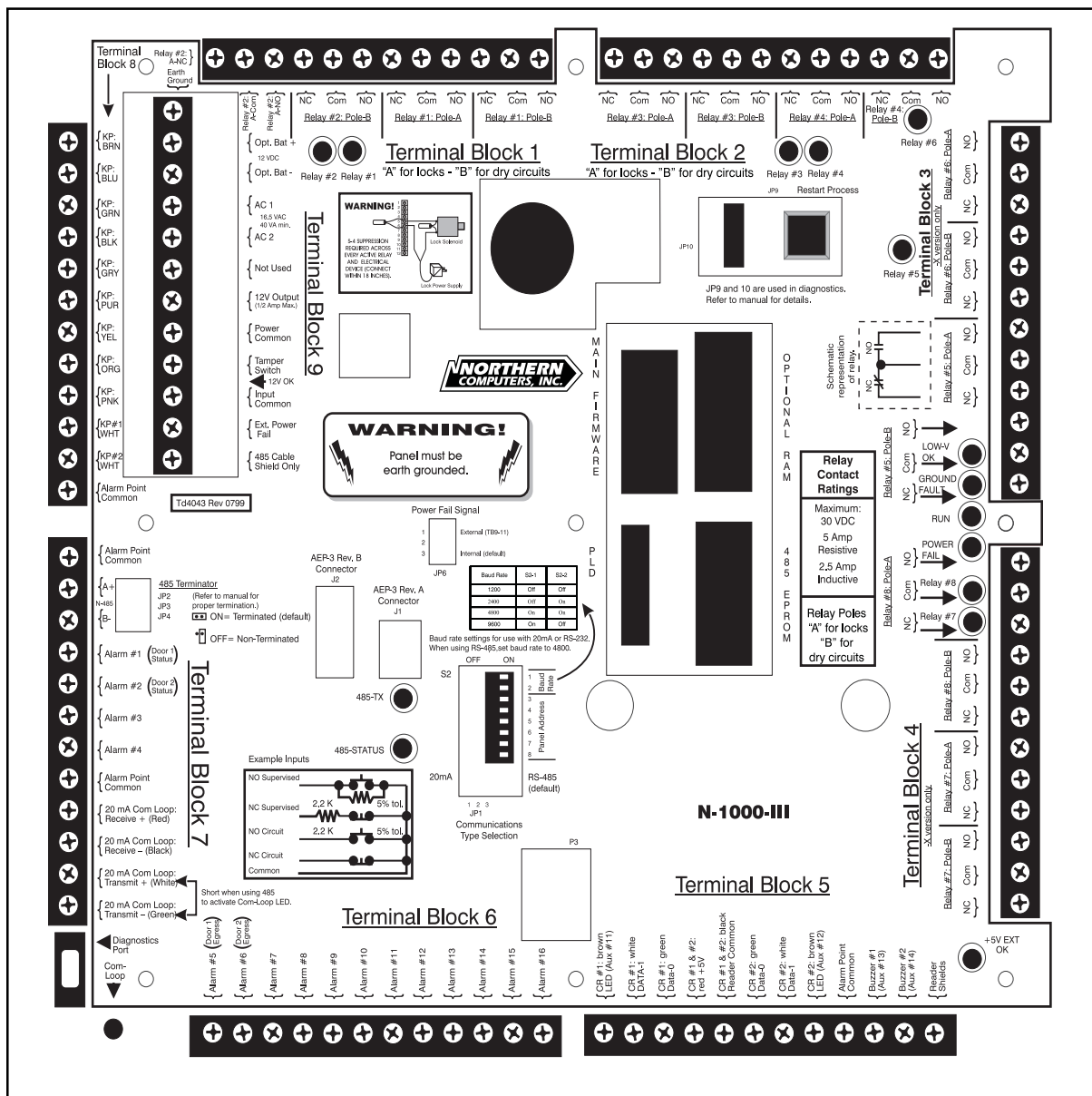
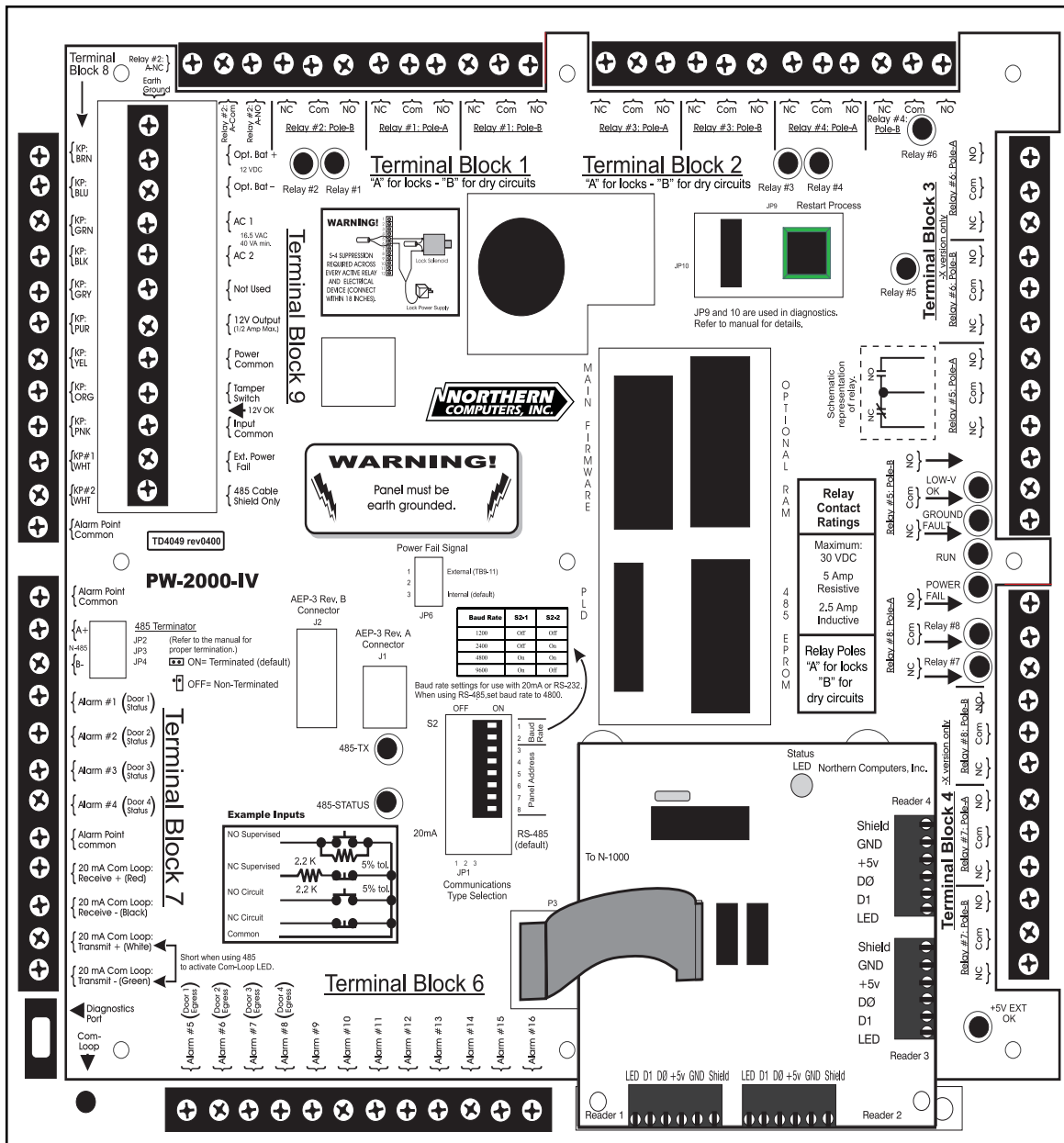

Figure 4-1. N-1000-III Panel. The panel is shown with its printed template.

4-1: Four Reader Board (N-1000-IV only)

The N-1000-IV supports up to four card readers. All four readers attach to the panel via a special Four Reader Board mounted in the lower right quadrant of the N-1000-IV panel (see Figure 4-2). The wiring terminals are removable and interchangeable. The regular reader terminals on the main board are not used. This board is connected to the main panel by connector P3, located directly above the bottom center of the N-1000 panel.

Typical wire color terminations are illustrated in Figure 4-3. Refer to the reader installation technical bulletin (included with the reader) for the most recent color terminations.



A special, programmable chip, called a PIC chip, controls the Four Reader Board. The PIC chip is labeled with a version number similar to the label on the main panel's PROM chips.

The Four Reader Board has its own Status LED that flashes when it is powered and running. When a card is read the Status LED gives a long flash. When the LED stays on for an extended period of time it indicates that the board has reset due to an error or power supply problem.

A pair of jumper prongs located on the Four Reader Board allows a reader function test. Shorting these prongs (labeled *TEST*) will cause the board to generate a simulated card read (with the PIC firmware version) from each of the four readers.

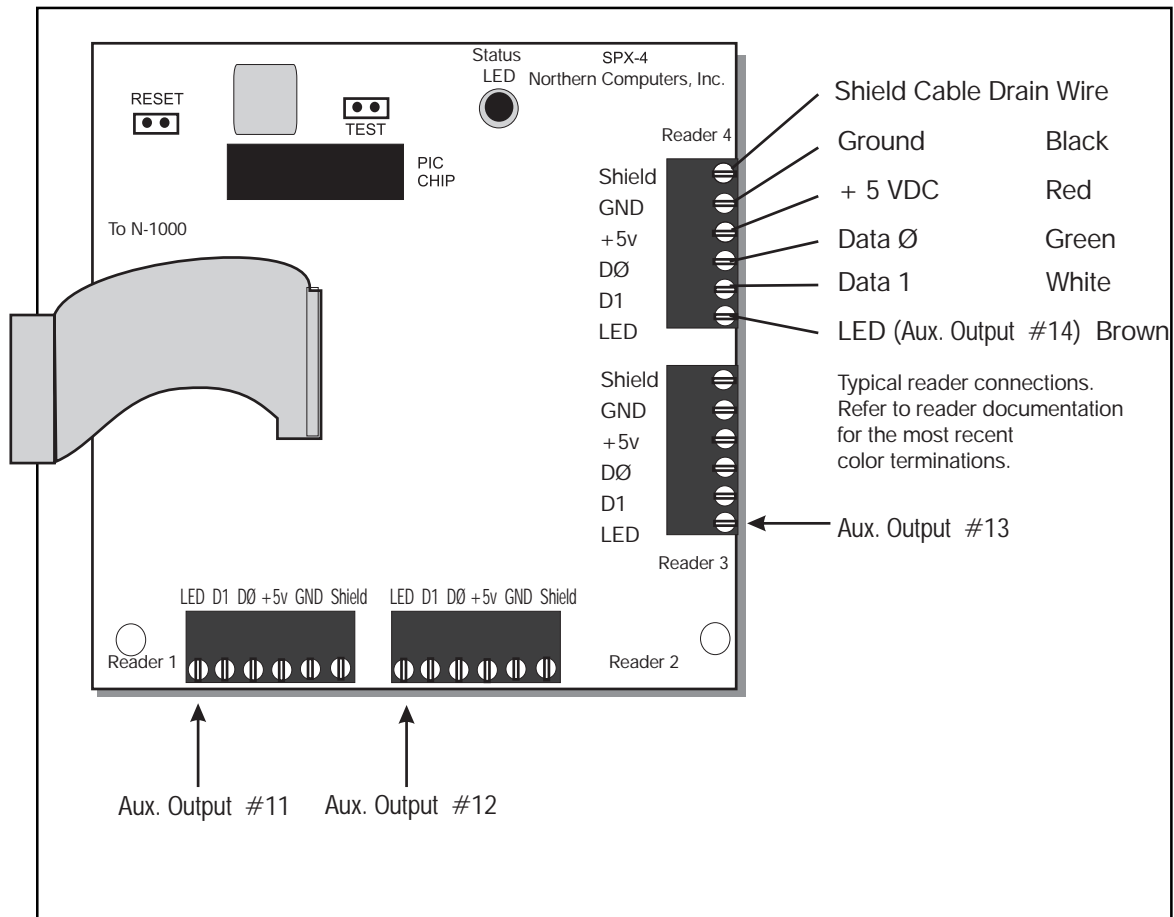

Figure 4-3. **Four Reader Board.** On the N-1000-IV the Four Reader Board replaces Terminal Block 5 and provides connections for up to four readers.

4-2: Terminal Blocks 1, 2, 3, 4

(Terminal Blocks 3 and 4 are available on the N-1000-III/IV-X only)

Each DPDT relay provides control for up to two external devices. Both poles of a given relay have a normally-closed terminal, a common terminal and a normally-open terminal. (See Figure 4-4.) Northern recommends using the A pole of the relays for locks (inductive loads) and the B pole for dry circuit (logic) application.

Terminal Block 1 provides relay contacts for relays 1 and 2.

Terminal Block 2 provides relay contacts for relays 3 and 4.

Terminal Block 3 provides relay contacts for relays 5 and 6.

Terminal Block 4 provides relay contacts for relays 7 and 8.

Terminal block 1, 2, 3, 4 terminations are as follow:

<i>Pos.</i>	<i>TB1</i>	<i>TB2</i>	<i>TB3</i>	<i>TB4</i>	<i>Function</i>
1	Relay 2: A	Relay 3: A	Relay 6: A	Relay 8: A	Normally-Closed
2	Relay 2: A	Relay 3: A	Relay 6: A	Relay 8: A	Common
3	Relay 2: A	Relay 3: A	Relay 6: A	Relay 8: A	Normally-Open
4	Relay 2: B	Relay 3: B	Relay 6: B	Relay 8: B	Normally-Closed
5	Relay 2: B	Relay 3: B	Relay 6: B	Relay 8: B	Common
6	Relay 2: B	Relay 3: B	Relay 6: B	Relay 8: B	Normally-Open
7	Relay 1: A	Relay 4: A	Relay 5: A	Relay 7: A	Normally-Closed
8	Relay 1: A	Relay 4: A	Relay 5: A	Relay 7: A	Common
9	Relay 1: A	Relay 4: A	Relay 5: A	Relay 7: A	Normally-Open
10	Relay 1: B	Relay 4: B	Relay 5: B	Relay 7: B	Normally-Closed
11	Relay 1: B	Relay 4: B	Relay 5: B	Relay 7: B	Common
12	Relay 1: B	Relay 4: B	Relay 5: B	Relay 7: B	Normally-Open

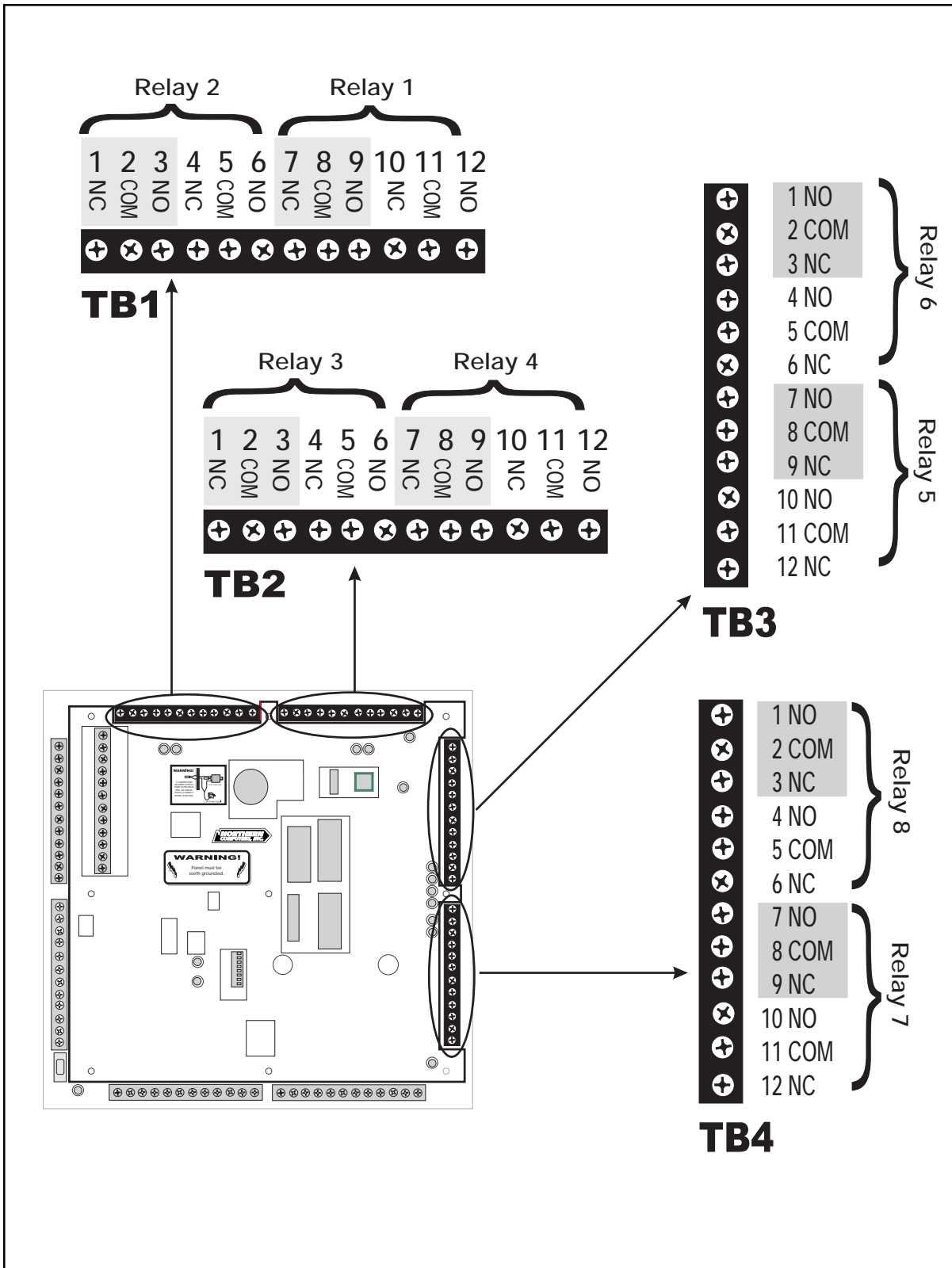

Figure 4-4. **Terminal Blocks 1, 2, 3, 4.** Terminal blocks 3 and 4 are available on the X versions of the N-1000-III/IV.

4-3: Terminal Block 5

Terminal Block 5 (**N-1000-III only**) supports the interface to two Wiegand output card readers and provides an alarm point common. Each card reader port includes terminals for LED control, Data 1 signal, Data Ø signal, + 5 VDC output and Ground. Figure 4-5 illustrates typical wire color terminations. Refer to Reader Installation Tech Bulletin (included with the reader) for most recent color terminations. Refer to *Section 6* for specific card reader wiring/installation details.

<i>Terminal</i>	<i>Function</i>	<i>Reader Wire Color</i>
1	Card Reader 1: LED (Aux. Output 11)	Brown
2	Card Reader 1: Data 1	White
3	Card Reader 1: Data Ø	Green
4	Card Readers 1 & 2: + 5 VDC	Red
5	Card Readers 1 & 2: Ground	Black
6	Card Reader 2: Data Ø	Green
7	Card Reader 2: Data 1	White
8	Card Reader 2: LED (Aux. Output 12)	Brown
9	Alarm Point Common*	
10	LED/Buzzer 3 (Aux. Output 13)	
11	LED/Buzzer 4 (Aux. Output 14)	
12	Earth Ground for Cable Shields	Shield

**All N-1000 alarm point commons are electrically the same and can be used with any panel alarm point.*

4-4: Terminal Block 6

Terminal Block 6 contains alarm input points 5-16 terminals. Any N-1000 alarm common can be used with the alarm inputs. (See Figure 4-5.)

<i>TB6 Terminal</i>	<i>Function</i>
1	Alarm Input 5 (Door 1 Egress)
2	Alarm Input 6 (Door 2 Egress)
3	Alarm Input 7 (Door 3 Egress N-1000-IV)
4	Alarm Input 8 (Door 4 Egress N-1000-IV)
5	Alarm Input 9
6	Alarm Input 10
7	Alarm Input 11
8	Alarm Input 12
9	Alarm Input 13
10	Alarm Input 14
11	Alarm Input 15
12	Alarm Input 16

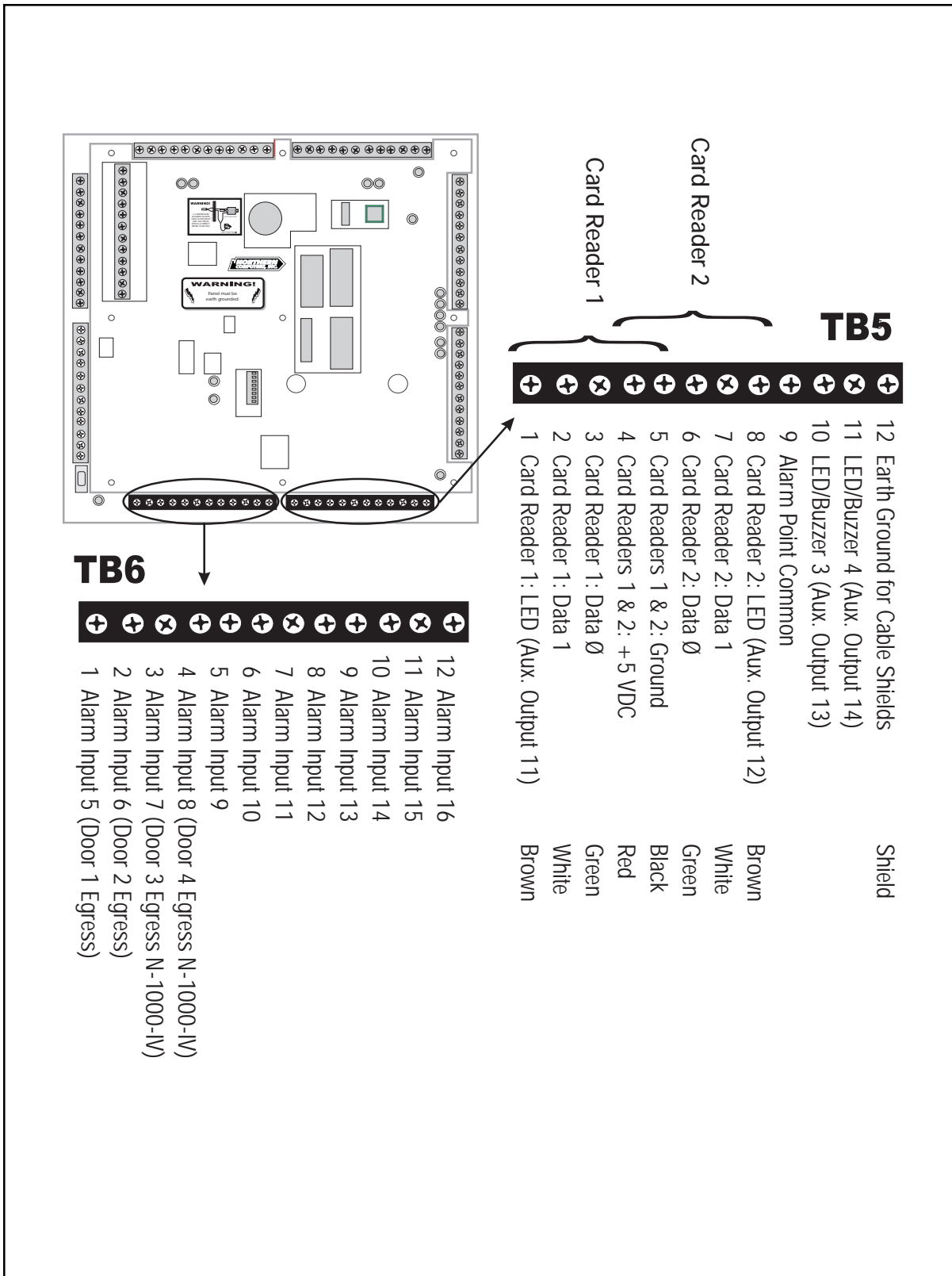

Figure 4-5. **Terminal Block 5 and Terminal Block 6.** Terminal Block 5 is only available on the N-1000-III. It supports the interface to two Wiegand output card readers and provides an alarm point common. Terminal Block 6 contains alarm input points 5-16 terminals. Any N-1000 alarm common can be used with the alarm inputs.

4-5: Terminal Block 7

Terminal Block 7 contains the 485 multi-drop communication connection, terminals for alarm input points 1 through 4, an alarm point common and the 20 mA communication loop (receive and transmit) terminals as illustrated in Figure 4-6.

NOTE: *The yellow communications LED (CR16) can be enabled when using RS-485 interface by shorting TB7-11 and TB7-12 together.*

Jumper settings on the panel are used to select either the 485 multi-drop or the 20 mA communications mode. The last panel on the 485 multi-drop cable must be properly configured. Refer to *Section 4-9, Jumpers*, for further information.

The 20 mA communication protocol specifications are as follow:

ASCII text characters

8 data bits

1 stop bit

No parity

(Refer to *Section 4-8* for baud rate settings.)

<i>Terminal</i>	<i>Function</i>	<i>Wire Color(s)</i>
1	Alarm Point Common*	
2	485 multi-drop (A+)	Red
3	485 multi-drop (B+)	Black
4	Alarm Input 1 (Door 1 status)	
5	Alarm Input 2 (Door 2 status)	
6	Alarm Input 3 (Door 3 status N-1000-IV)	
7	Alarm Input 4 (Door 4 status N-1000-IV)	
8	Alarm Point Common*	
9	20 mA Communication Loop: Receive+	Red
10	20 mA Communication Loop: Receive-	Black
11	20 mA Communication Loop: Transmit+	White
12	20 mA Communication Loop: Transmit-	Green

**All N-1000 alarm point commons are electrically the same and can be used with any panel alarm points.*

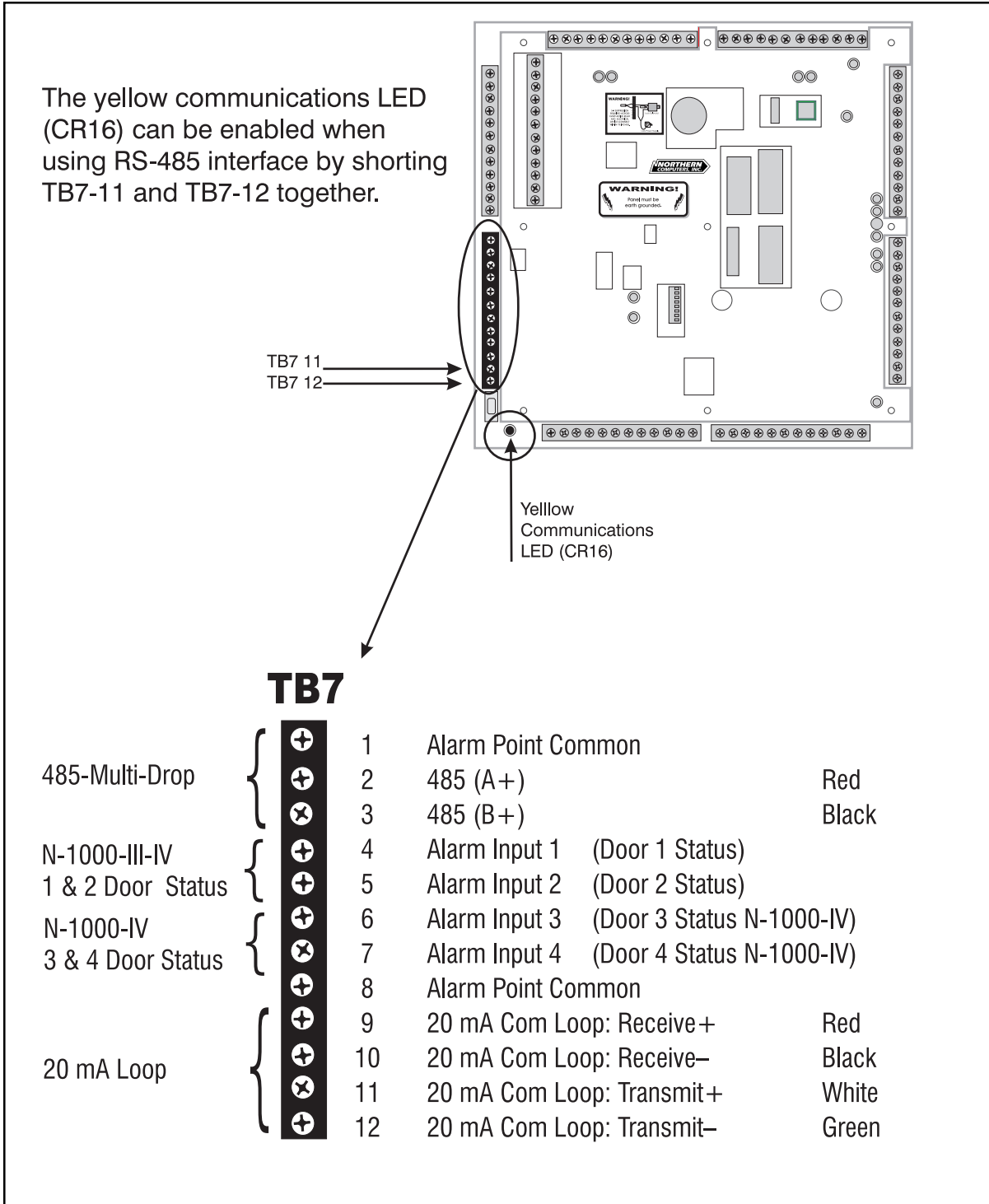

Figure 4-6. **Terminal Block 7.** Terminal Block 7 contains the 485 multi-drop communication connection terminals for alarm input points 1 through 4, an alarm point common and the 20 mA communication loop (receive and transmit) terminals.

4-6: Terminal Block 8

Terminal Block 8 is used for 11-conductor matrix keypad connections and also provides an alarm point common. (See Figure 4-7.)

Refer to 11-Conductor Keypad instructions (*Section 6*) for 2 of 7 matrix (row/column) information.

Keypad Use:

TB8 Terminal	Color/Function
1	Brown (Column 1)
2	Blue (Column 2)
3	Green (Column 3)
4	Black (Common)
5	Gray (Row 1)
6	Purple (Row 2)
7	Yellow (Row 3)
8	Orange (Row 4)
9	Peach/Pink (+ 5v)
10	Keypad 1: White (Select 1)
11	Keypad 2: White (Select 2)
12	Alarm Point Common*

4-7: Terminal Block 9

Terminal Block 9 is located just to the right of terminal Block 8. It has the power supply and auxiliary connections. See Figure 4-7. The 12 volt back-up battery wires are soldered to the circuit board. When connecting an external DC supply the N-1000-III/IV 12 VDC battery can remain connected and provides additional battery backup.

<i>TB9 Terminal</i>	<i>Function</i>
1	Transformer Earth Ground (DO NOT USE if panel is already connected to earth ground. Refer to <i>Section 8-1</i> .)
2	External DC Supply + (12 V battery +)
3	External DC Supply - (12 V battery -)
4	AC Transformer Wire 1
5	AC Transformer Wire 2
6	Not Used
7	+ 12V DC Output (500 mA - not for Locking Device)
8	DC Common*
9	Tamper Switch Input
10	Input Common*
11	External Power Fail Input
12	485 Shield (if used)

*All N-1000 alarm point commons are electrically the same and can be used with any panel alarm points.

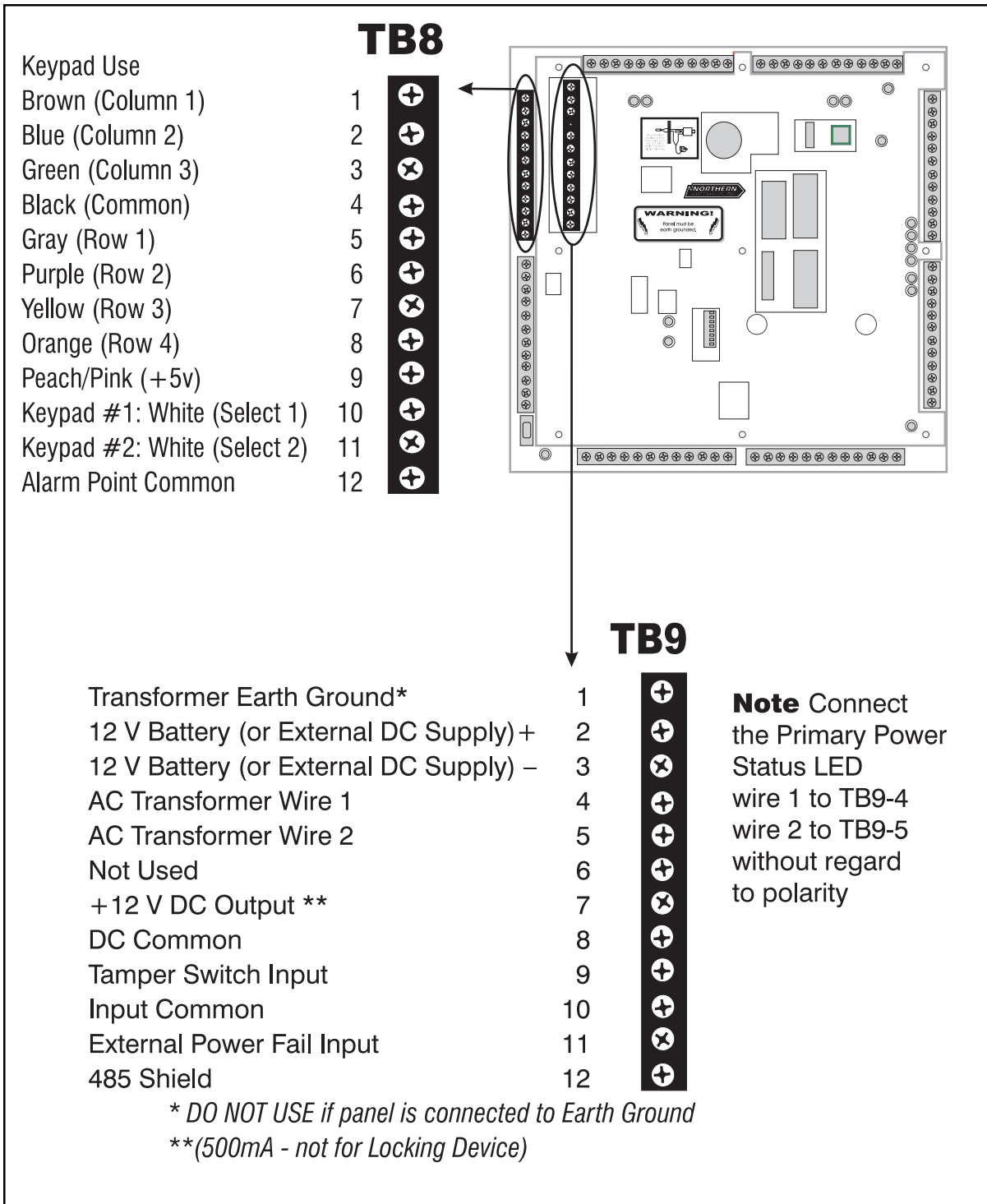

Figure 4-7. **Terminal Blocks 8 & 9.** Terminal Block 8 is used for 11-conductor matrix keypad connections and also provides an alarm point common. Terminal Block 9 is located just to the right of Terminal Block 8. It has the power supply and auxiliary connections.

4-8: DIP Switch Settings

N-1000-III/IV DIP switch positions 1 and 2 control the panel baud rate for the 20 mA Loop. Set the panel baud rate to match that of the system programming device. 1200 baud is recommended for computer and data terminal systems. For 485 communications use the 4800 baud setting.

N-1000-III/IV DIP switch positions 3 through 8 determine a control panel's address. (See Figure 4-8.) Each control panel in the communication loop must have a unique address to allow unique referencing during system programming. When running the panel's self-test, set all DIP switches to the On position before restarting the panel. (For details of the self-test, refer to *Appendix C: Trouble Shooting*.)

Baud rate and panel address DIP switch settings are as follow:

Baud Rate	1	2	Panel No.	3	4	5	6	7	8
1200	Off	Off	1	On	On	On	On	On	Off
2400	Off	On	2	On	On	On	On	Off	On
4800	On	On	3	On	On	On	On	Off	Off
9600	On	Off	4	On	On	On	Off	On	On
			5	On	On	On	Off	On	Off
			6	On	On	On	Off	Off	On
			7	On	On	On	Off	Off	Off
			8	On	On	Off	On	On	On
			9	On	On	Off	On	On	Off
			10	On	On	Off	On	Off	On
			11	On	On	Off	On	Off	Off
			12	On	On	Off	Off	On	On
			13	On	On	Off	Off	On	Off
			14	On	On	Off	Off	Off	On
			15	On	On	Off	Off	Off	Off
			16	On	Off	On	On	On	On
			17	On	Off	On	On	On	Off
			18	On	Off	On	On	Off	On

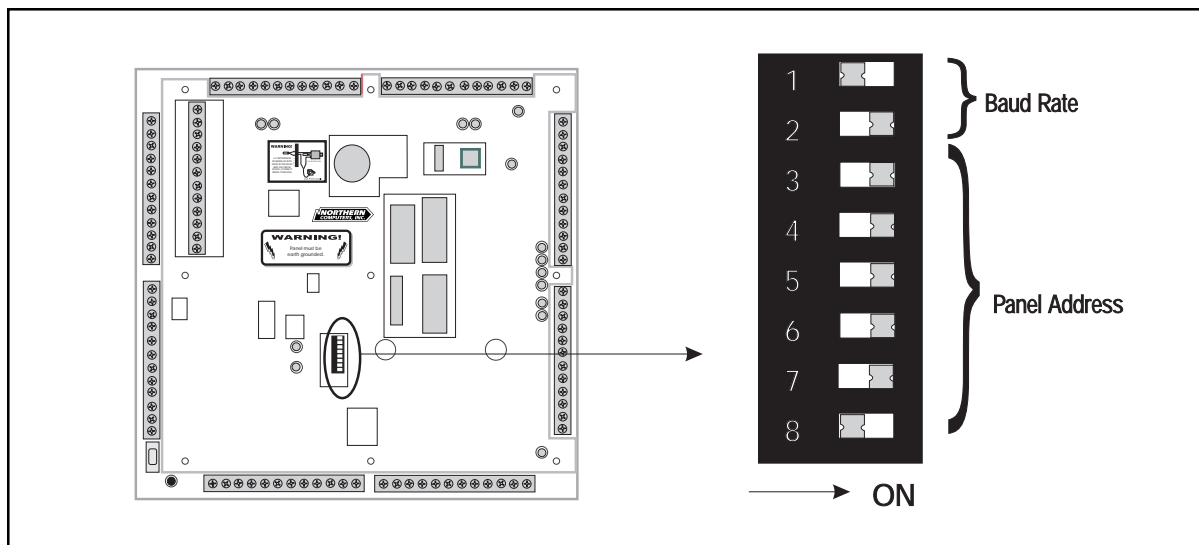

Figure 4-8. **DIP Switches.** Switch positions 1 and 2 control the panel baud rate for the 20 mA loop; switch positions 3 through 8 determine the control panel's address. The positions above are set for panel 1 and a baud rate of 2400.

	Panel	3	4	5	6	7	8
	19	On	Off	On	On	Off	Off
	20	On	Off	On	Off	On	On
	21	On	Off	On	Off	On	Off
	22	On	Off	On	Off	Off	On
	23	On	Off	On	Off	Off	Off
	24	On	Off	Off	On	On	On
	25	On	Off	Off	On	On	Off
	26	On	Off	Off	On	Off	On
	27	On	Off	Off	On	Off	Off
	28	On	Off	Off	Off	On	On
	29	On	Off	Off	Off	On	Off
	30	On	Off	Off	Off	Off	On
	31	On	Off	Off	Off	Off	Off
NOTE: Addresses 32 and above cannot be used with the 485 multi-drop.	32	Off	On	On	On	On	On
	33	Off	On	On	On	On	Off
	34	Off	On	On	On	Off	On
	35	Off	On	On	On	Off	Off
	36	Off	On	On	Off	On	On
	37	Off	On	On	Off	On	Off
	38	Off	On	On	Off	Off	On
	39	Off	On	On	Off	Off	Off
	40	Off	On	Off	On	On	On
	41	Off	On	Off	On	On	Off
	42	Off	On	Off	On	Off	On
	43	Off	On	Off	On	Off	Off
	44	Off	On	Off	Off	On	On
	45	Off	On	Off	Off	On	Off
	46	Off	On	Off	Off	Off	On
	47	Off	On	Off	Off	Off	Off
	48	Off	Off	On	On	On	On
	49	Off	Off	On	On	On	Off
	50	Off	Off	On	On	Off	On
	51	Off	Off	On	On	Off	Off
	52	Off	Off	On	Off	On	On
	53	Off	Off	On	Off	On	Off
	54	Off	Off	On	Off	Off	On
	55	Off	Off	On	Off	Off	Off
	56	Off	Off	Off	On	On	On
	57	Off	Off	Off	On	On	Off
	58	Off	Off	Off	On	Off	On
	59	Off	Off	Off	On	Off	Off
	60	Off	Off	Off	Off	On	On
	61	Off	Off	Off	Off	On	Off
	62	Off	Off	Off	Off	Off	On
	63	Off	Off	Off	Off	Off	Off

NOTE: For DIP switches with OPEN/CLOSED notation:
 OPEN= Off CLOSED= On

NOTE: The restart button **MUST** be pressed to activate a change made to any DIP switch setting (for baud rate and/or panel address). Pressing the restart button **DOES NOT** alter N-1000-III/IV database memory.

4-9: Jumpers

There are several jumpers on the circuit board (Figure 4-9) which configure the panel for various modes of operation as indicated below:

<i>Number</i>	<i>Position</i>	<i>Function</i>
JP1	Jump Pins 1 & 2	Select 20 mA communications loop.
	Jump Pins 2 & 3	Select 485 multi-drop communications (default).
JP2	Open	Provide end of line (EOL) termination for 485 drop line. Refer to <i>Section 6-6-8</i> for details.
JP3	Open	
JP4	Jump Pins 1 & 2	Jumper is on for the panel at the end of the 485 multi-drop cable (default).
	Remove	Remove the jumper if the panel is not at the end of the cable or JP2 and JP3 are used. Refer to <i>Section 6-6-8</i> for details.
JP5	(Not Used)	
JP6	Jump pins 2 & 3	Select onboard power status detection (default).
	Jump Pins 1 & 2	Select external power status detection.
JP7	(Not Used)	
JP8	(Not Used)	
JP9	Jump Pins 1 & 2	Disable clearing of RAM by JP10 (default).
	Remove	Enable clearing the RAM by JP10.
JP10	Jump Pins 1 & 2	Clears RAM when power is off for at least 60 seconds and JP9 is removed.
	Remove	Will not clear RAM, allows supercap to backup memory (default).
JP11	(Not Used)	

4-10: Connectors

Connector	Function
Battery Wires	Red and Black wires soldered to the circuit board with fast-on connectors for the 12 volt backup battery
J1	Four pin connector for the AEP-3 (Revision A) Relay Expansion Board(s)
J2	Eight pin connector for the AEP-3 (Revision B) Relay Expansion Board(s)

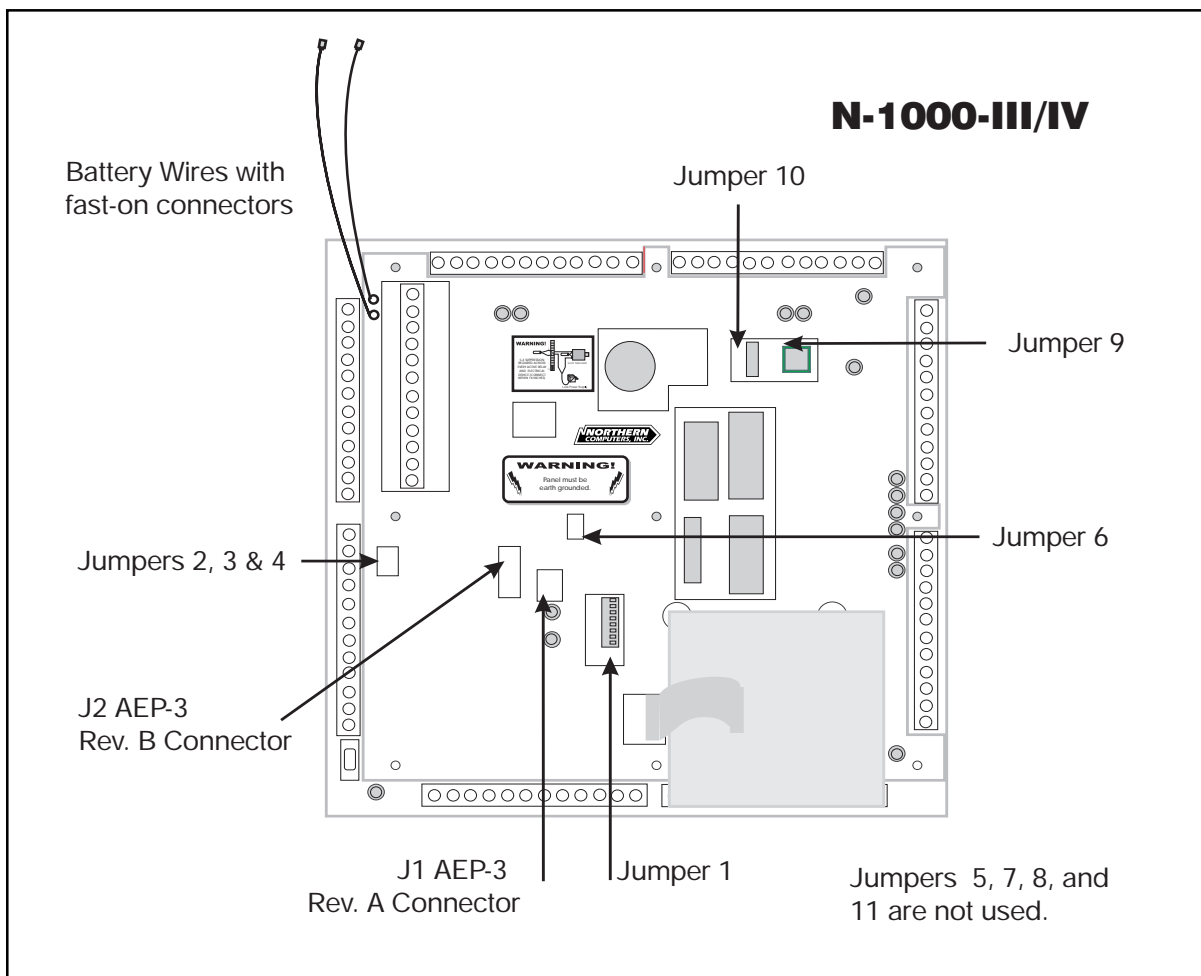

Figure 4-9. **Configuration Jumpers and Connectors.** The N-1000-III/IV panels provide for either 485 multi-drop communication or 20 mA communication loops. These modes are selected by changing jumper settings.

4-11: LEDs

The functions of the N-1000-III/IV LEDs are listed below and also illustrated in Figure 4-10. When an LED is lit it indicates that its relay is energized, that is the normally open relay contacts become closed and the normally closed relay contacts become open. Not lit indicates relay is de-energized, that is normally open and normally closed contacts are in normal state.

<i>Function</i>	<i>LED</i>	<i>Color</i>	<i>Lit Indicates</i>
Output Relay 1 Indicator:	1	Red	Energized
Output Relay 2 Indicator:	2	Red	Energized
Output Relay 3 Indicator:	3	Red	Energized
Output Relay 4 Indicator:	4	Red	Energized
Output Relay 5 Indicator:	5	Red	Energized
Output Relay 6 Indicator:	6	Red	Energized
Output Relay 7 Indicator:	7	Red	Energized
Output Relay 8 Indicator:	8	Red	Energized
485 Status:	9	Green	Slow flashing indicates proper 485 communications
+ 12 VDC Indicator:	10	Green	12 V DC external power is available
+ 5 VDC Indicator:	11	Green	Panel is supplying + 5 VDC output for reader/keypad power
Low-Voltage OK:	12	Green	Battery voltage acceptable and RAM back-up available
Input Ground:	13	Red	Ground fault detected
Run:	14	Green	Pulsing indicates N-1000 microprocessor operating properly (not lit or not pulsing indicates malfunction)
Power Status:	15	Red	Loss of primary power with panel powered by 12 VDC battery (fast flashing indicates battery charge is too low to operate panel even with primary power available)
Com Loop Indicator:	16	Yellow	Loop current is present (flashing off indicates data flow)
485-TX:	17	Red	Periodic quick flashing indicates 485 communications link functioning properly
Four Reader Board Status		Green	Quick flash indicates processor running, long flash indicates card read, very long flash indicates reset due to error or power problem

*indicator turns off at approx. 10 volts, the panel shuts down at approx. 9.9 volts

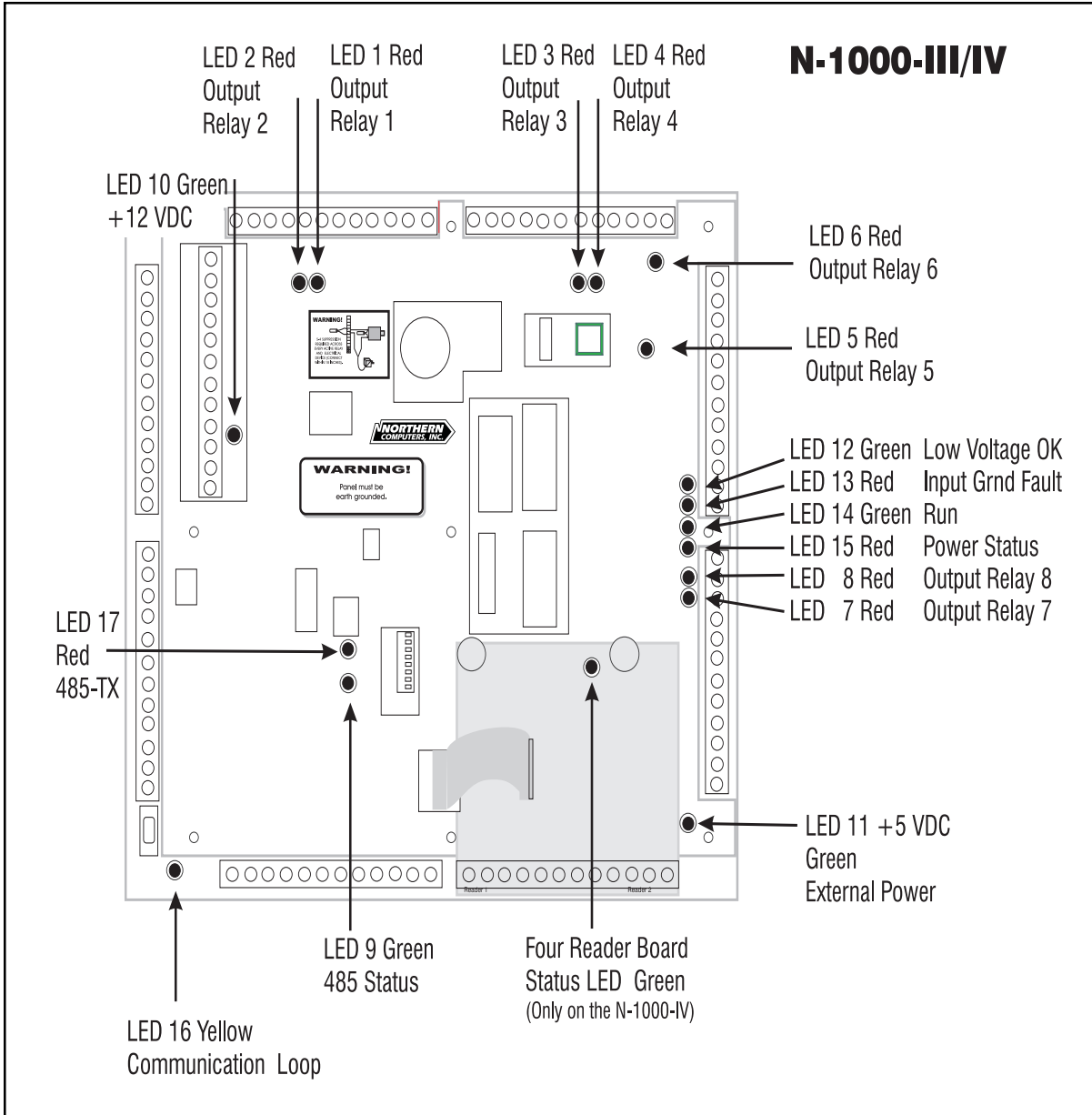

Figure 4-10. **LED Functions.** When an LED is lit it indicates that its relay is energized, that is, the normally open relay contacts become closed and the normally closed relay contacts become open. Not lit indicates relay is de-energized, that is normally open and normally closed contacts are in normal state.

4-12: Restart Button

The restart button is used to restart the N-1000-III/IV microprocessor. (See Figure 4-11.) Press the restart button to restart a “locked-up” control panel and to activate a change made to any DIP switch setting (for baud rate and/or panel address).

The panel’s self-test feature can be activated by setting all of the DIP switches to the On position and then depressing the Restart button. For details of the self-test, refer to Appendix C: Troubleshooting.

Pressing the Restart button DOES NOT alter N-1000-III/IV database memory. The data base can be completely cleared by the following method: Disconnect the AC power and battery back-up. Move jumper JP9 to position JP10 for one minute then return it to JP9. Restore the power connections.

4-13: RAM Chip

Control panel RAM chips store all database and transaction buffer memory. The N-1000-III/IV control panels use a single RAM chip with the option of an additional chip in socket U6. The N-1000-III/IV-X control panels come equipped with an extra RAM chip. (See Figure 4-11.)

NOTE: Control panel card database and transaction buffer capacities are determined by the number of RAM chips used and can be modified by use of the U command I option. Refer to Appendix A: Programming Quick Reference Guide for details.

4-14: PROM Chip

The control panel PROM chips store all N-1000-III/IV program and control logic memory and are located in sockets U5 & U19. (See Figure 4-11.) On each PROM is a sticker which indicates the socket number and the firmware version of the chip. Refer to the main PROM number when referencing the N-1000-III/IV Programming Manual for specific programming/operation functions.

4-15: Additional Installation Information

Northern Computers recommends the following installation techniques for the N-1000 panels:

DO

- Do run all wiring for door locks/strikes and panel primary power in a separate conduit or allow at least 12 inches of space between the power cables and the data/reader cables.
- Do use shielded cables or metal conduit when necessary to reduce interfering radio frequency emissions.

DO NOT

- *Do not* mount the power supplies, modem, or external relays inside the panel enclosure. An empty enclosure (ENC-0 or ENC-2) is available for this purpose. It is the same size as the N-1000 enclosure, with the same locking mechanism.
- *Do not* “string” wire across the face of the panel.
- *Do not* use the same power supply for both locks and control panel or locks and readers.
- *Do not* mount the control panel in or near an area that has electric noise (e.g., next to a large electric motor or power transformer).

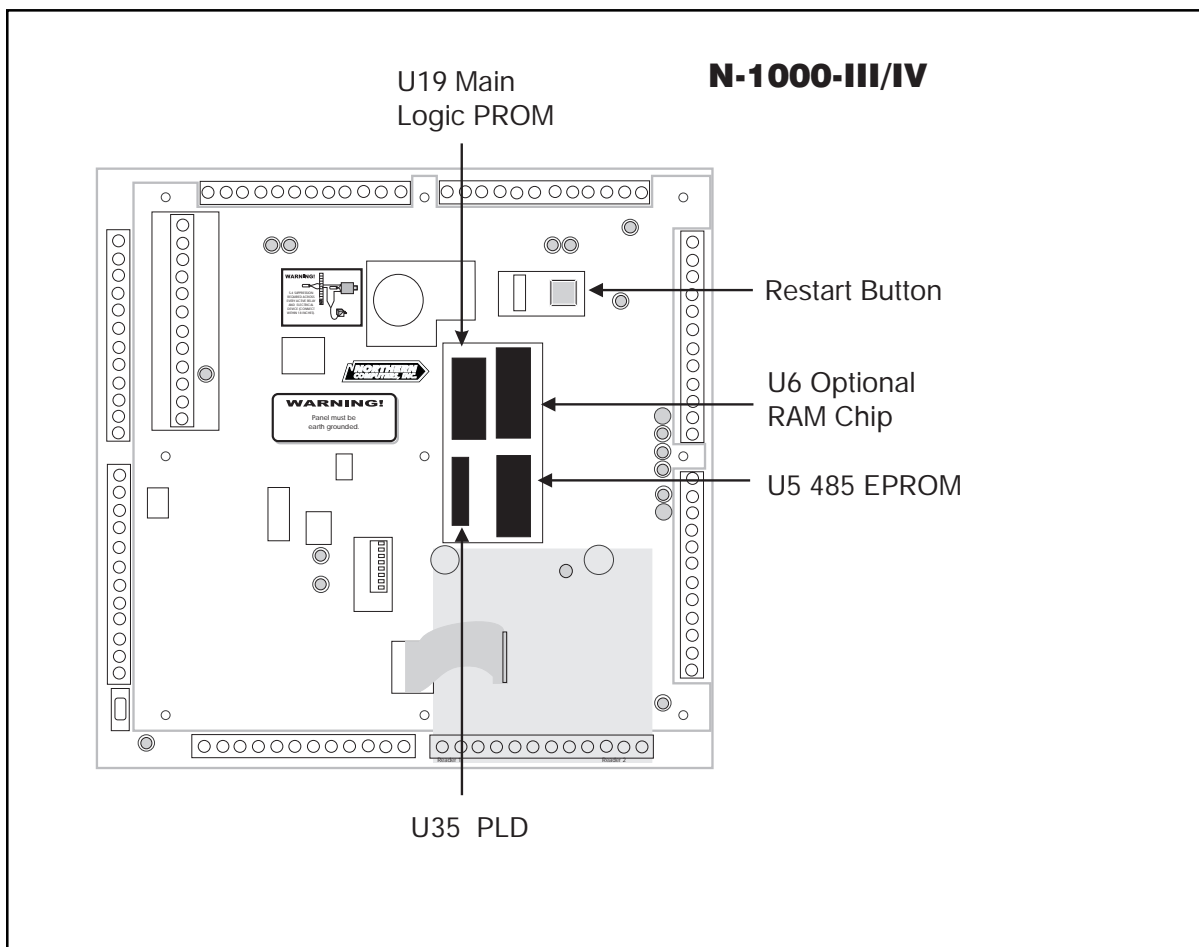

Figure 4-11. **Additional Panel Features.** The restart button is used to restart the N-1000-III/IV microprocessor. It can be used to restart a “locked-up” control panel or to activate a change made to any DIP switch setting (for baud rate and/or panel address). The N-1000-III/IV-X control panel comes equipped with an additional RAM chip, located in socket U6. The control panel PROM chips, located in sockets U5 & U19, store all N-1000-III/IV program and control logic memory.

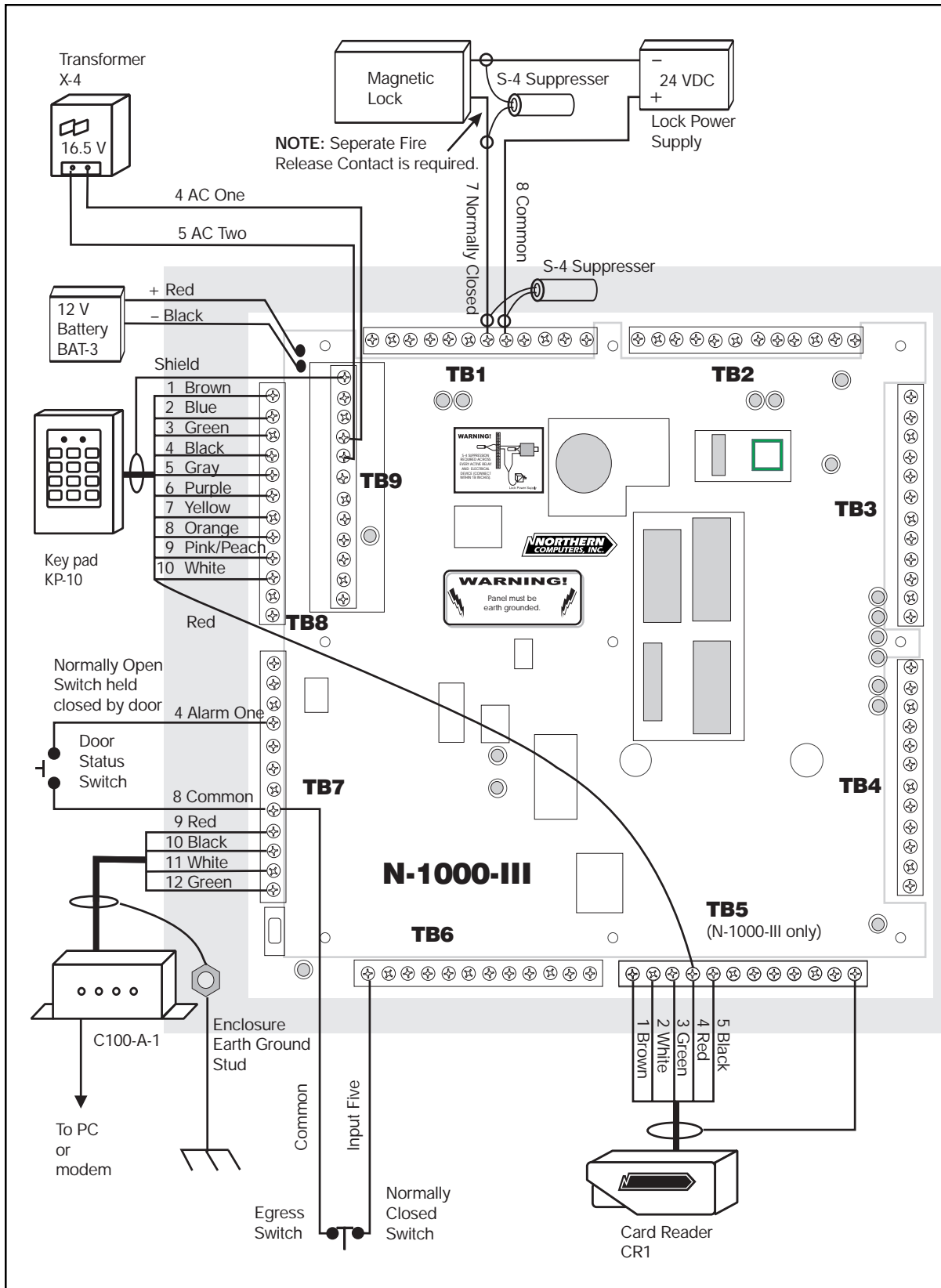

Figure 4-12. **Example Wiring Diagram.** Card Readers connect to TB5 of the N-1000-III as shown here. On the N-1000-IV, the card readers connect to the Four Reader Board. Refer to Section 4-3 for typical wiring diagram.

Section 5: Operation

5-1: Card Reader/Keypad Operation

Some card readers require that a format (software) command be programmed into the host N-1000-III/IV controller before cards can be read. If the format command is not programmed into the control panel, these readers or keypads will not transmit card numbers to the terminal/printer. Refer to *Appendix A: Programming Quick Reference Guide* for complete F Command format listings.

Verify card reader/keypad operation before programming. Codes need not be programmed into memory to verify reader/keypad operation. When a code is entered or a card presented, it should appear on the display/printer, followed by an NF or not found message.

The control panel continuously monitors the card reader and keypad ports for code use. Access is restricted by placing time zone limitations on the codes in use, NOT by time zone controlling (disabling) the reading devices.

Card reader or keypad activation of output points is determined by the presence or absence of the anti-passback option in panel memory. Refer to I Command, A Option in *Appendix A* for further information.

In anti-passback configurations with two card readers or two keypads, both devices activate Output Relay 1 (Door 1) upon valid code use (Figure 5-1). In anti-passback applications requiring a separate output relay for the reader (such as turnstile applications), refer to A Command in *Appendix A*.

In configurations WITHOUT anti-passback enabled, Card Reader or Keypad 1 activates Output Relay 1 (Door 1) and Card Reader or Keypad 2 activates Output Relay 2 (Door 2) (Figure 5-2).

Card readers and keypads can be reassigned to activate a specified input point, output point or group (multiple outputs) upon valid code use, via the A Command. Refer to *Appendix A*.

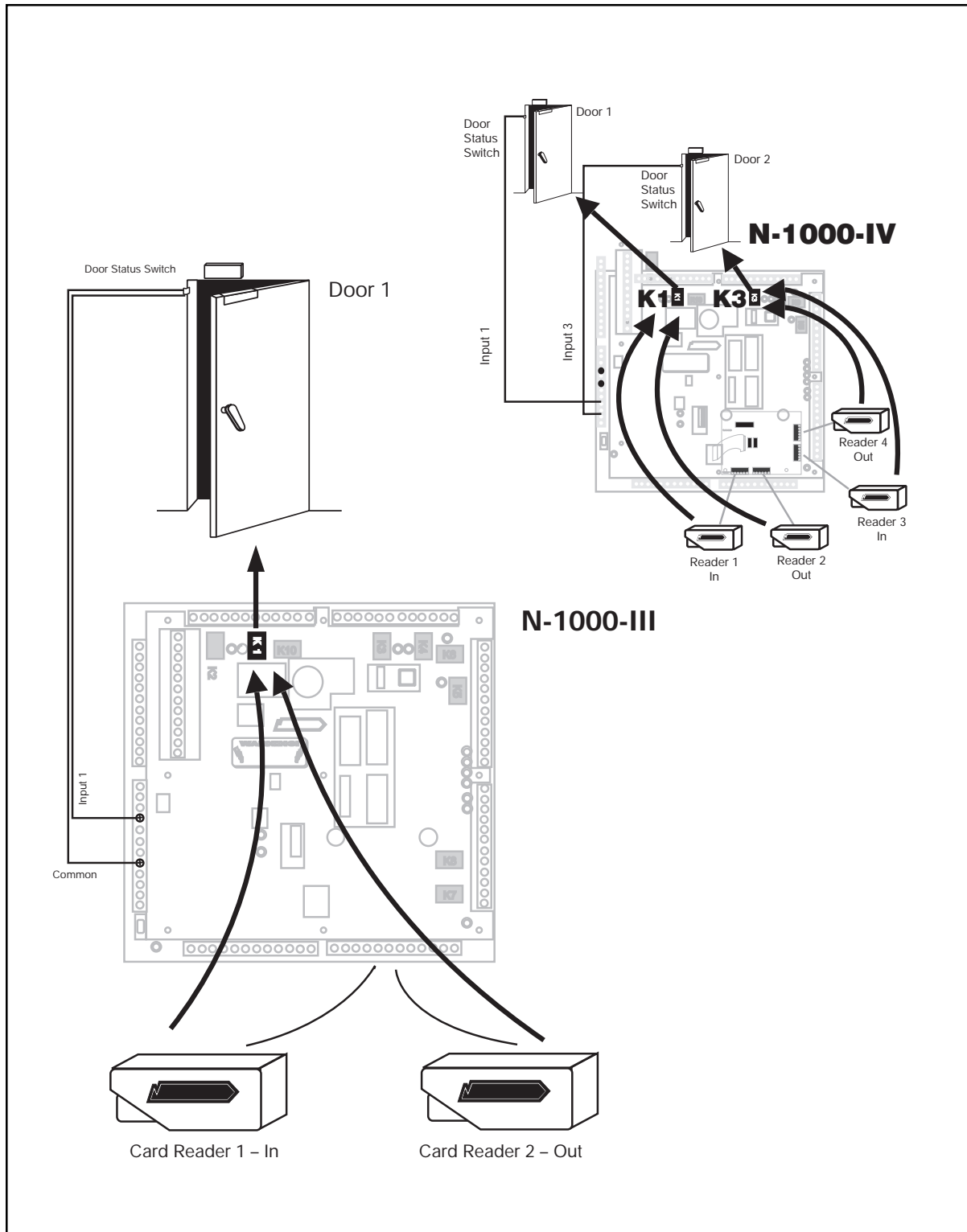

Figure 5-1. **Anti-passback with Two and Four Card Readers.** (Keypads may be substituted for card readers on TB8). In anti-passback configurations with two card readers, both devices activate Output Relay 1 (Door 1) upon valid code use. With four card readers, readers 1 and 2 activate Output Relay 1 (Door 1); reader 3 and 4 activate Output Relay 3 (Door 2). In anti-passback applications requiring a separate output relay for each reader (such as turnstile applications) refer to Appendix A, A Command.

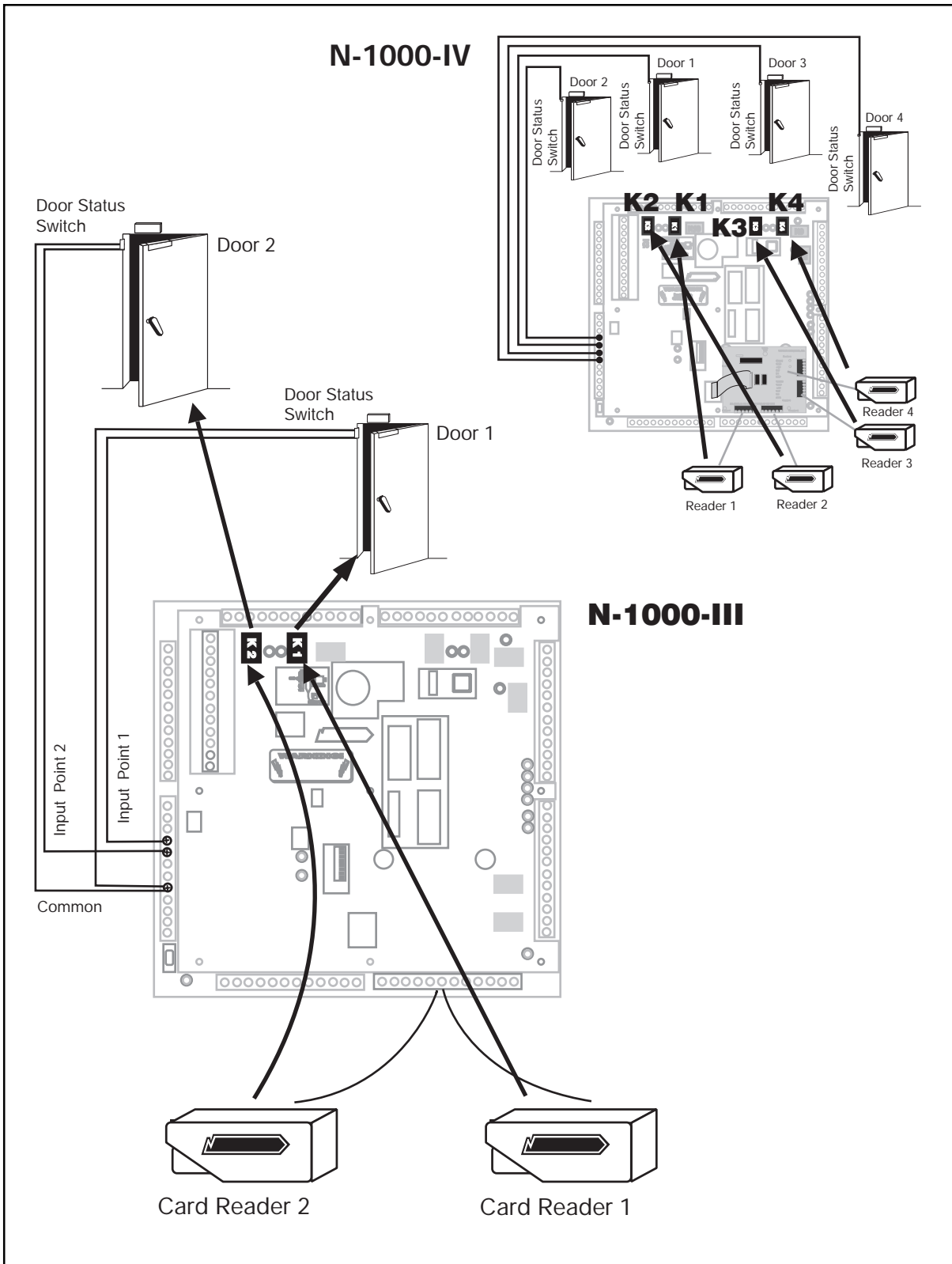

Figure 5-2. **Two and Four Card Readers without Anti-passback.** In configurations *WITHOUT* anti-passback enabled, card reader 1 activates Output Relay 1 (Door 1) and card reader or keypad 2 activates Output Relay 2 (Door 2). With four readers, card readers 1, 2, 3, and 4 activate output relays 1, 2, 3, and 4 activating doors 1, 2, 3, and 4 respectively.

5-2: Alarm Input Points

All N-1000 alarm input points default to normally-closed, non-supervised circuits used to monitor changes of state. N-1000-III/IV inputs can also be configured for normally-open circuits and 3-state supervised circuits. Input points have both a physical state and a software state, as described below:

Physical State

Input points have physical states of OPEN and CLOSED. An open input is considered to be in ALARM condition. A closed input is considered to be in NORMAL condition.

Software State

Input points have software states of UNSHUNTED (active) and SHUNTED (not active). When an input is unshunted, all physical changes of state (openings and closures) are recognized. When an input is shunted, physical changes of state are

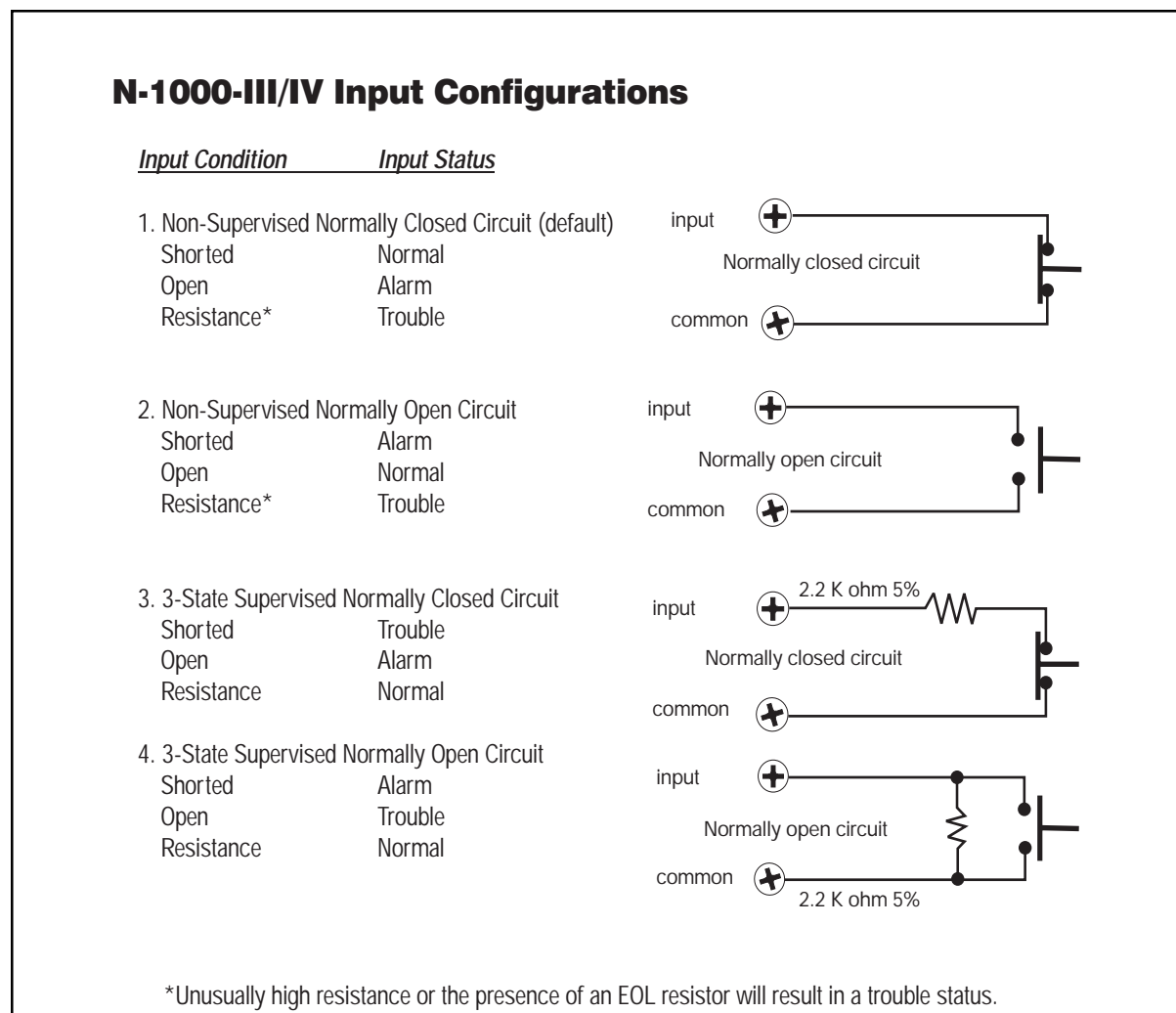

Figure 5-3. **Input Point configuration.**

not recognized. Input shunting is software controlled and does not involve a physical change of state of the input.

The default software state of all input points is unshunted. No programming is necessary to keep inputs in the default state. Programming is only necessary to shunt input points.

Input Points are assigned both shunt time and time zone parameters, as described below:

Shunt Time

The shunt time parameter defines the amount of time the input point is shunted (deactivated) when triggered, such as upon valid code use.

Time Zone

The time zone parameter defines the time the input point is automatically shunted (deactivated).

5-3: Relay Output Points

All N-1000-III/IV relay output points have both normally-open and normally-closed contacts, used to switch (activate/deactivate) electrical devices. Output points have only a physical state, as described below:

Physical State

Output points have physical states of DE-ENERGIZED and ENERGIZED. When an output is de-energized, normally-open and normally-closed contacts are in normal state. When an output is energized, normally-open contacts become closed and normally-closed contacts become open.

The default state of all output points is de-energized. No programming is necessary to keep outputs in the default state. Programming is only necessary to energize output points.

Door locks **MUST** be wired such that the following conditions are met:

1. **DE-ENERGIZED** relay outputs (default state) result in **LOCKED** doors.
2. **ENERGIZED** relay outputs result in **UNLOCKED** doors.

NOTE: *The appropriate side of the relay contact (normally-open or normally-closed) MUST be used to satisfy the conditions stated.*

Output points are assigned both pulse time and time zone parameters, as described below:

Pulse Time

The pulse time parameter defines the amount of time the output point is energized when triggered, such as upon valid code use.

Time Zone

The time zone parameter defines the time the output is automatically energized.

Outputs 11 & 12 control Card Reader 1 and Card Reader 2 LEDs, respectively. On the N-1000-IV panel, outputs 13 & 14 control Card Reader 3 and Card Reader 4 LEDs, respectively. Card reader LEDs change state upon valid code use for the duration of the programmed pulse time. Default pulse time for LED outputs is two seconds. Refer to *Appendix A, I Command, M Option and V Command* for further card reader LED information.

5-4: Default Input Point/Output Point Interaction

The actions of all input points and output points are independent of one another, unless otherwise programmed. Selected inputs and outputs can be programmed to interact with one another through an interlocking option (refer to *Appendix A, P Command* as well as *I Command, E Option*). Interlocking allows an input point or output point to take a specified action, based upon another input point or output point change of state.

The reserved input and output points, default interlocks, default pulse times and default shunt times for various system configurations (without anti-passback, with anti-passback and with free egress) are shown below:

Configurations WITHOUT Anti-Passback

<i>Input Point</i>	<i>Reserved for:</i>	<i>Default shunt time</i>
Input 1	Door position switch for Door 1	15 seconds
Input 2	Door position switch for Door 2	15 seconds
Input 3*	Door position switch for door 3	15 seconds
Input 4*	Door position switch for door 4	15 seconds
<i>Output Point</i>	<i>Reserved for:</i>	<i>Default pulse time</i>
Output 1	Door lock for Door 1	10 seconds
Output 2	Door lock for Door 2	10 seconds
Output 3*	Door lock for door 3	10 seconds
Output 4*	Door lock for door 4	10 seconds
Output 11	Reader 1 LED	2 seconds
Output 12	Reader 2 LED	2 seconds
Output 13*	Reader 3 LED	2 seconds
Output 14*	Reader 4 LED	2 seconds

**N-1000-IV only*

Output 1 is interlocked to Input 1. An activation of Output 1 (such as upon valid code use at card reader/keypad 1) causes Input 1 to be shunted for the duration of its shunt time.

Similarly, outputs 2, 3 and 4 are interlocked to inputs 2, 3 and 4 respectively. Activation of an interlocked output causes the respective interlocked input to be shunted for the duration of its shunt time. (See Figure 5-4.)

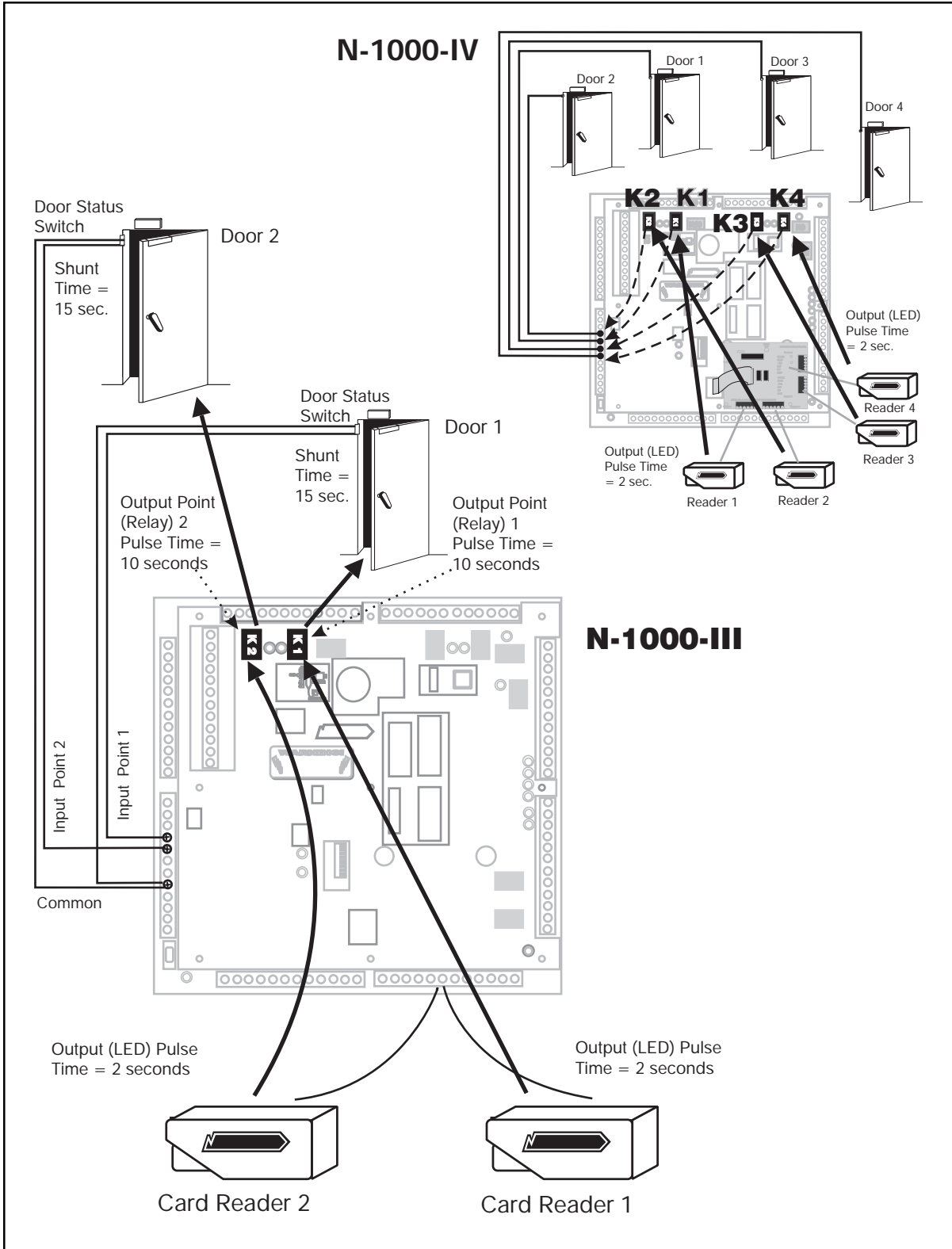

Figures 5-4. Interlocked Input/Output on Doors Without Anti-passback.
 Example: Valid code use at card reader (or keypad) 1 triggers the pulse time of Output Relay 1, unlocking Door 1 for 10 seconds and pulsing the reader LED for 2 seconds.
 The activation of Output 1 triggers the shunt time of Input 1 (via interlock) shunting Door 1 status switch for 15 seconds.

Configurations WITH Anti-Passback:

<i>Input Point</i>	<i>Reserved for:</i>	<i>Shunt Time</i>
Input 1	Door position switch for Door 1	15 seconds
Input 3*	Door position switch for Door 2	15 seconds
<i>Output Point</i>	<i>Reserved for:</i>	<i>Pulse Time</i>
Output 1	Door lock for Door 1	10 seconds
Output 3*	Door lock for Door 2	10 seconds

Output 1 is interlocked to Input 1. Activation of Output 1 causes Input 1 to be shunted for the duration of its shunt time.

Similarly, on the N-1000-IV only, Output 3 is interlocked to Input 3. Activation of Output 3 causes Input 3 to be shunted for the duration of its shunt time. (See Figure 5-5.)

Configurations With Free Egress:

<i>Input Point</i>	<i>Reserved for:</i>	<i>Default shunt time</i>
Input 1	Door position switch for Door 1	15 seconds
Input 2	Door position switch for Door 2	15 seconds
Input 3*	Door position switch for Door 3	15 seconds
Input 4*	Door position switch for Door 4	15 seconds
Input 5	Egress device for Door 1	0 seconds (N/A)
Input 6	Egress device for Door 2	0 seconds (N/A)
Input 7*	Egress device for Door 3	0 seconds (N/A)
Input 8*	Egress device for Door 4	0 seconds (N/A)
<i>Output Point</i>	<i>Reserved for:</i>	<i>Default pulse time</i>
Output 1	Door lock for Door 1	10 seconds
Output 2	Door lock for Door 2	10 seconds
Output 3*	Door lock for Door 3	10 seconds
Output 4*	Door lock for Door 4	10 seconds

Input 5 is interlocked to Output 1. An activation of Input 5 (via egress attempt) causes Output 1 to energize for the duration of its pulse time.

Input 6 is interlocked to Output 2. An activation of Input 6 (via egress attempt) causes Output 2 to energize for the duration of its pulse time.

Output 1 is interlocked to Input 1. An activation of Output 1 (such as upon valid code use at card reader/keypad 1 or egress attempt) causes Input 1 to be shunted for the duration of its shunt time.

Output 2 is interlocked to Input 2. An activation of Output 2 (such as upon valid code use at Card Reader/Keypad 2 or egress attempt) causes Input 2 to be shunted for the duration of its shunt time. (See Figure 5-6.)

*N-1000-IV only

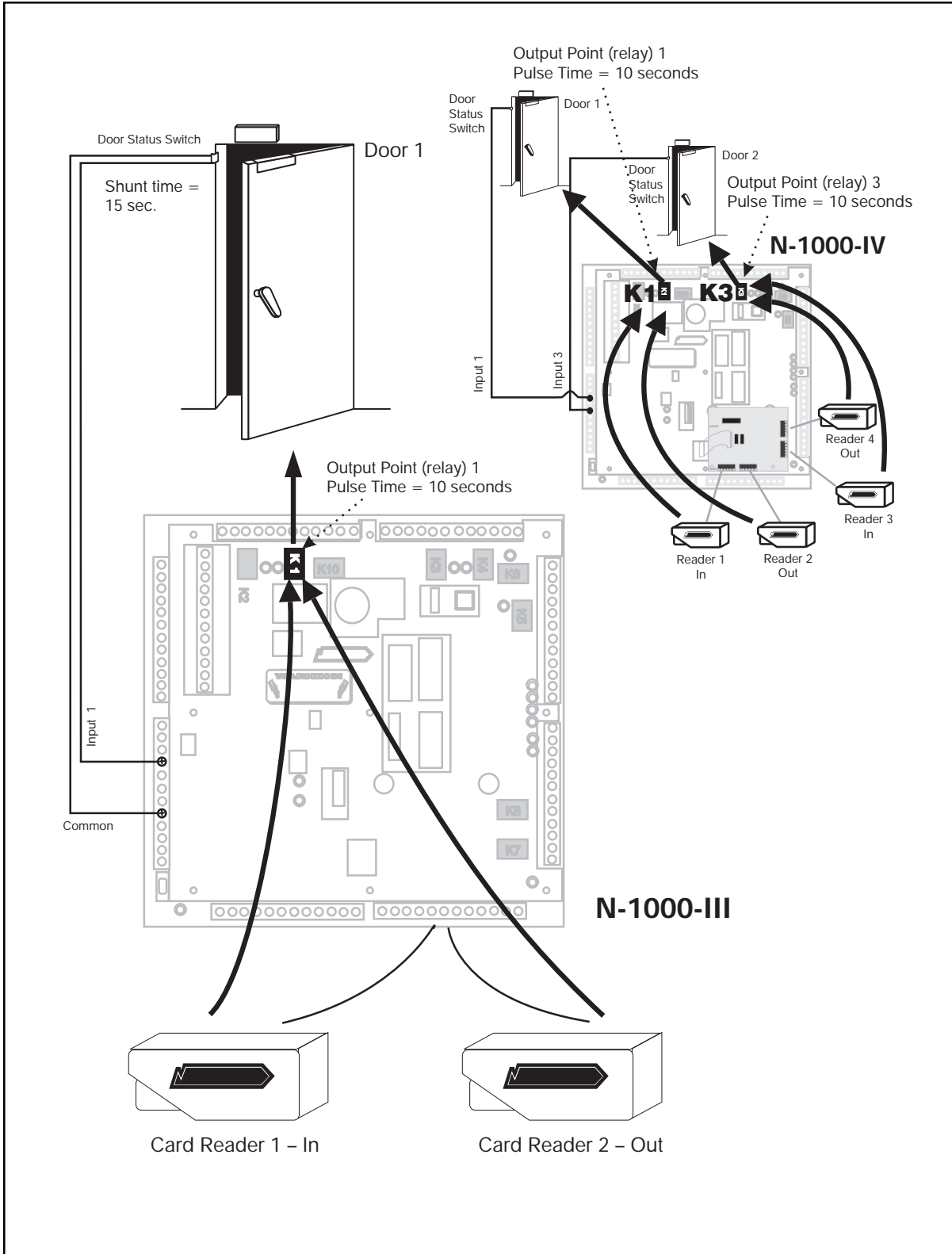

Figure 5-5 Interlocked Input/Output Points on Door WITH Anti-passback.
 Example: Valid code use at either card reader (or keypad) triggers the pulse time of Output Relay 1, unlocking Door 1 for 10 seconds. The activation of Output 1 triggers the shunt time of Input 1 (via the interlock), shunting Door 1 status switch for 15 seconds.

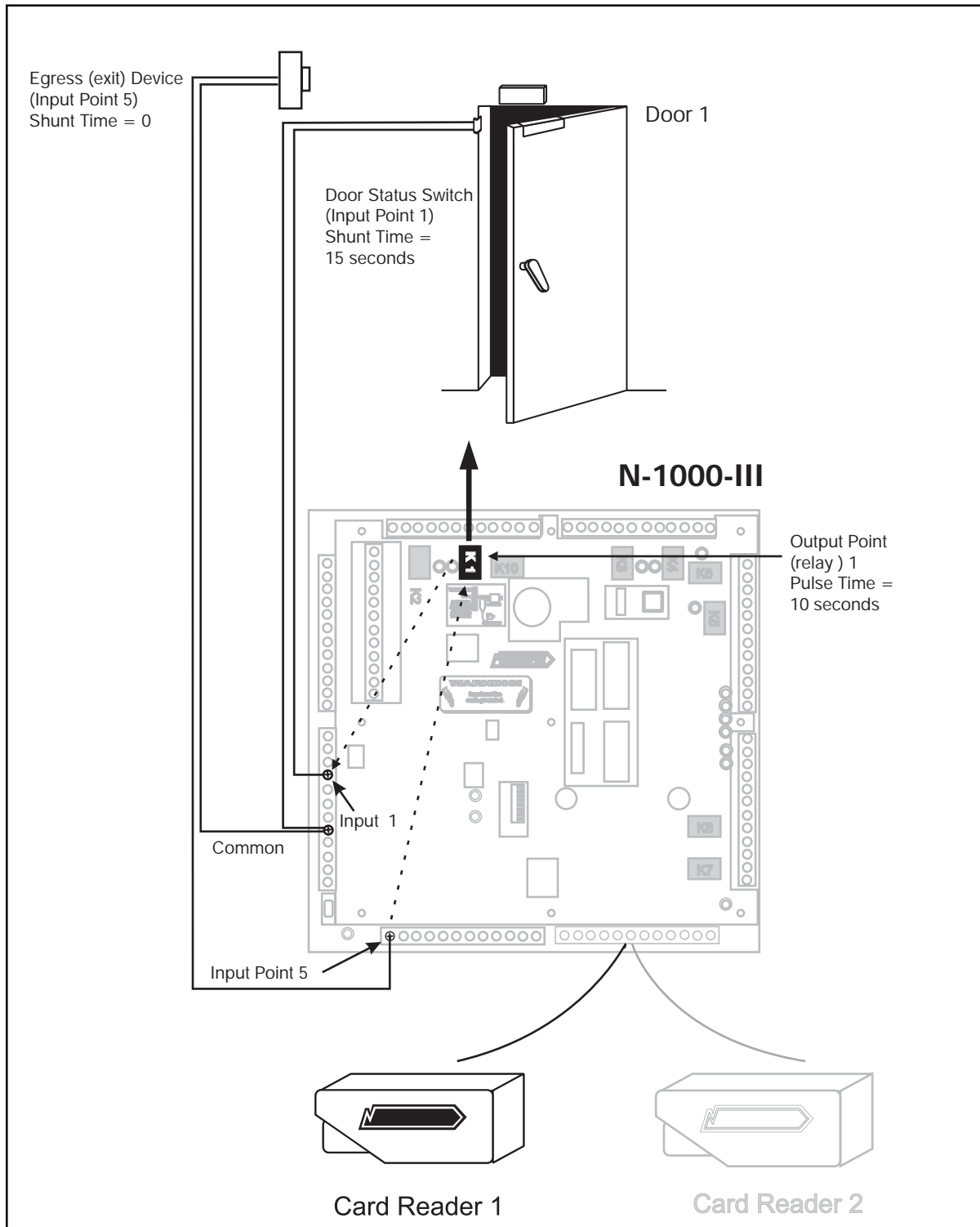

Figure 5-6. Door 1 with Free Egress. Valid code use at card reader (or keypad) 1 OR egress attempt (at Input 5) triggers the pulse time of Output Relay 1, unlocking Door 1 for 10 seconds. The activation of Output 1 triggers the shunt time of Input 1 (via the interlock), shunting Door 1 status switch for 15 seconds. Input 1 is shunted for the duration of its shunt time (15 seconds by default) upon valid code use OR upon egress attempt. Door 1 shunt time is determined by Input 1 shunt time, NOT Input 5 shunt time. Input 5 shunt time does not apply.

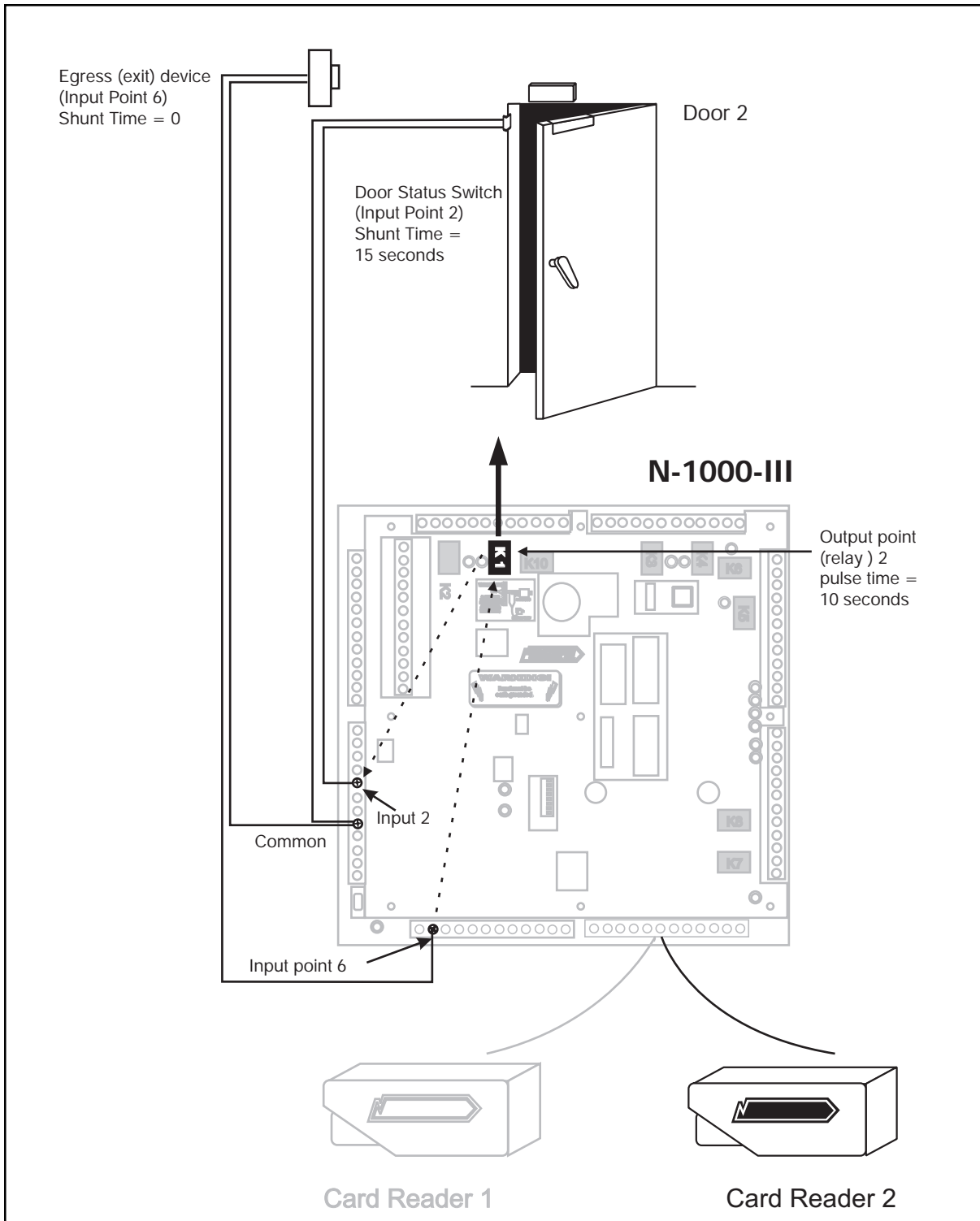

Figure 5-7. Door 2 with Free Egress. Valid code use at Card Reader (or Keypad) 2 OR egress attempt (at Input 6) triggers the pulse time of Output Relay 2, unlocking Door 2 for 10 seconds. The activation of Output 2 triggers the shunt time of Input 2 (via the interlock), shunting Door 2 status switch for 15 seconds. Input 2 is shunted for the duration of its shunt time (15 seconds by default) upon valid code use OR upon egress attempt. Door 2 shunt time is determined by Input 2 shunt time, NOT Input 6 shunt time. Input 6 shunt time does not apply.

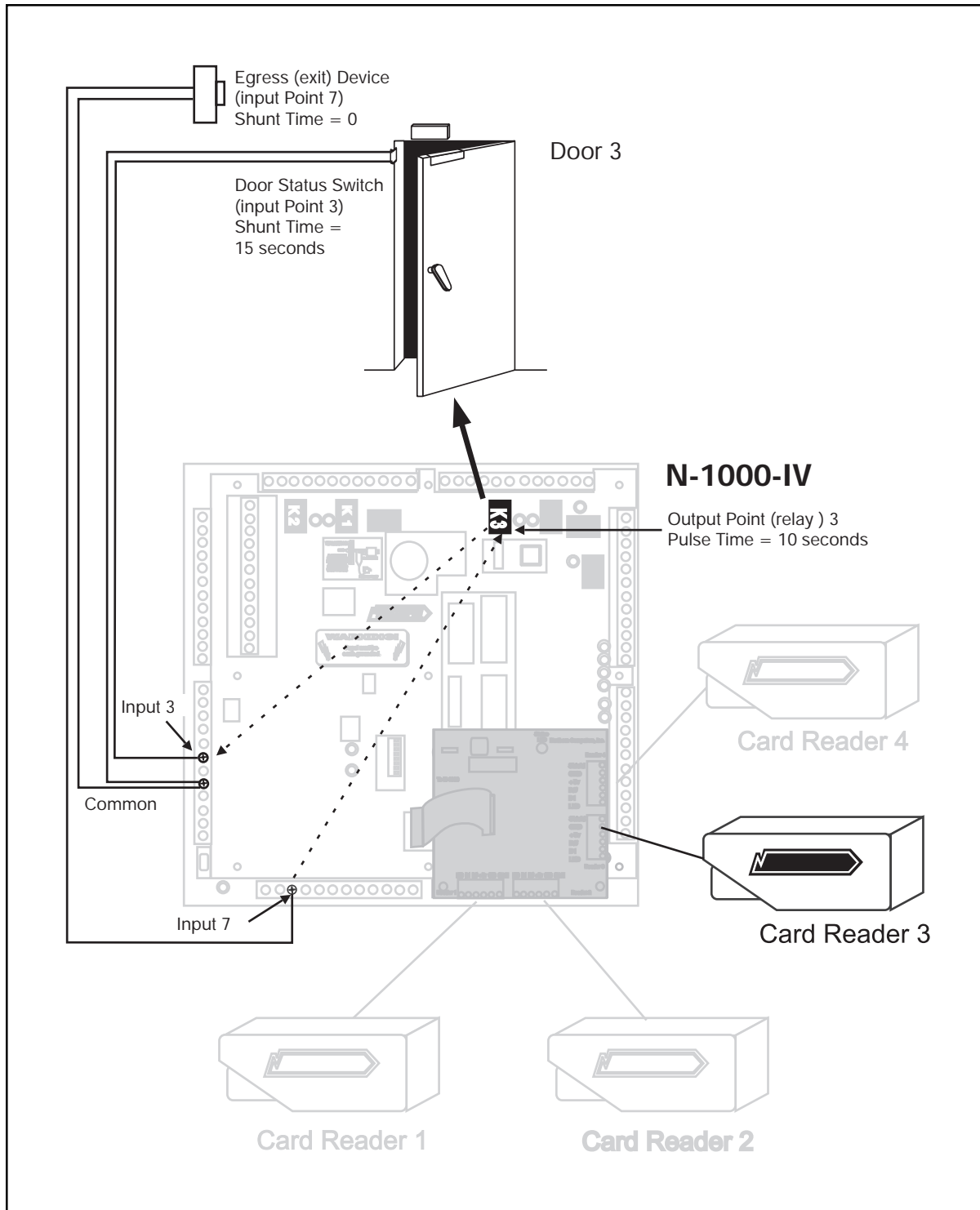

Figure 5-8. Door 3 with Free Egress. Valid code use at card reader 3 OR egress attempt (at Input 7) triggers the pulse time of Output Relay 3, unlocking door 3 for 10 seconds. The activation of Output 3 triggers the shunt time of Input 3 (via the interlock), shunting door 3 status switch for 15 seconds. Input 3 is shunted for the duration of its shunt time (15 seconds by default) upon valid code use or egress attempt. Door 3 shunt time is determined by Input 3 shunt time, not Input 7 shunt time. Input 7 shunt time does not apply.

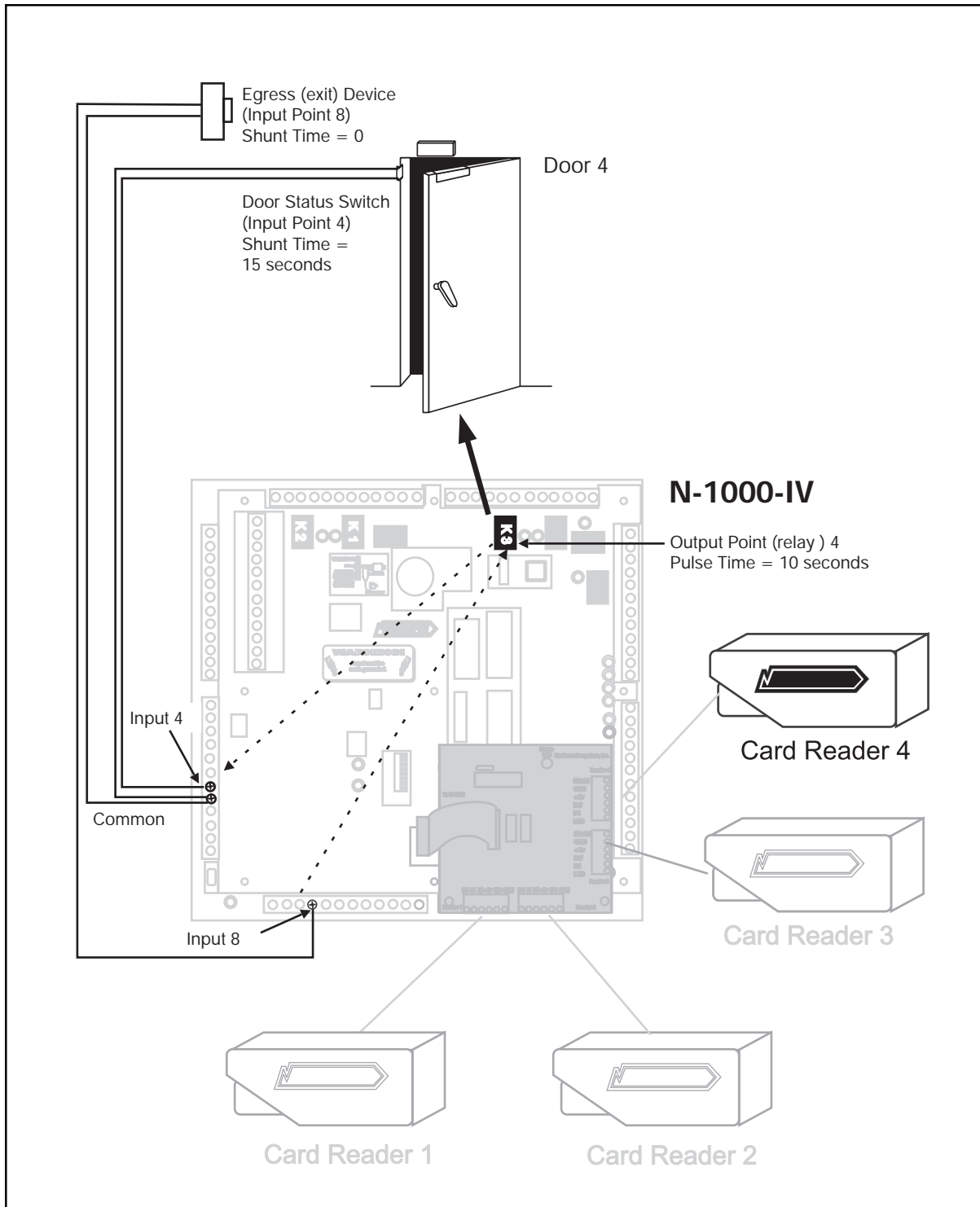

Figure 5-9. Door 4 with Free Egress. Valid code use at card reader 4 OR egress attempt (at Input 8) triggers the pulse time of Output Relay 4, unlocking door 4 for 10 seconds. The activation of Output 4 triggers the shunt time of Input 4 (via the interlock), shunting door 4 status switch for 15 seconds. Input 4 is shunted for the duration of its shunt time (15 seconds by default) upon valid code use or egress attempt. Door 4 shunt time is determined by Input 4 shunt time, not Input 8 shunt time. Input 8 shunt time does not apply.

5-5: Auto-Relock Operation

The auto-relock feature results in the immediate re-locking and re-arming (unshunting) of a door when the door status switch is closed after entry. With auto-relock operation, an output relay (controlling a door lock) de-energizes when the corresponding Input Point (door status switch) returns to normal state, and the Input Point is re-armed (unshunted) rather than remaining energized (shunted) for the duration of its pulse/shunt time.

Auto-relock associations between inputs and outputs are NOT considered interlocks and do not appear as interlocks on Input Point reports and output point reports.

Auto-relock operation can be set manually with the V Command, K option found in *Appendix A*.

Default auto-relock operation is described below and illustrated in Figure 5-10, 5-11 and 5-12.

With Anti-Passback

With anti-passback enabled, Input 1 is configured for auto-relock with Output 1.

Without Anti-Passback

Without anti-passback enabled, Input Point 1 is configured for auto-relock with Output 1 and Input 2 is configured for auto-relock operation with Output 2.

5-6: Time Zone Controlled Doors

When Time Zone controlling a door (for free access) that is operated by a card reader or keypad, the Time Zone must be assigned to the relay output point.

Example:

Want to keep Door 1 (controlled by Card Reader 1) unlocked during Time Zone 5, defined as 9 A.M. to 6:30 P.M., Monday through Friday.

Time Zone 5 must be assigned to Output 1 to unlock the door during the time zone.

The default interlock to shunt the door status switch will prevent an alarm from occurring while the output is pulse/energized.

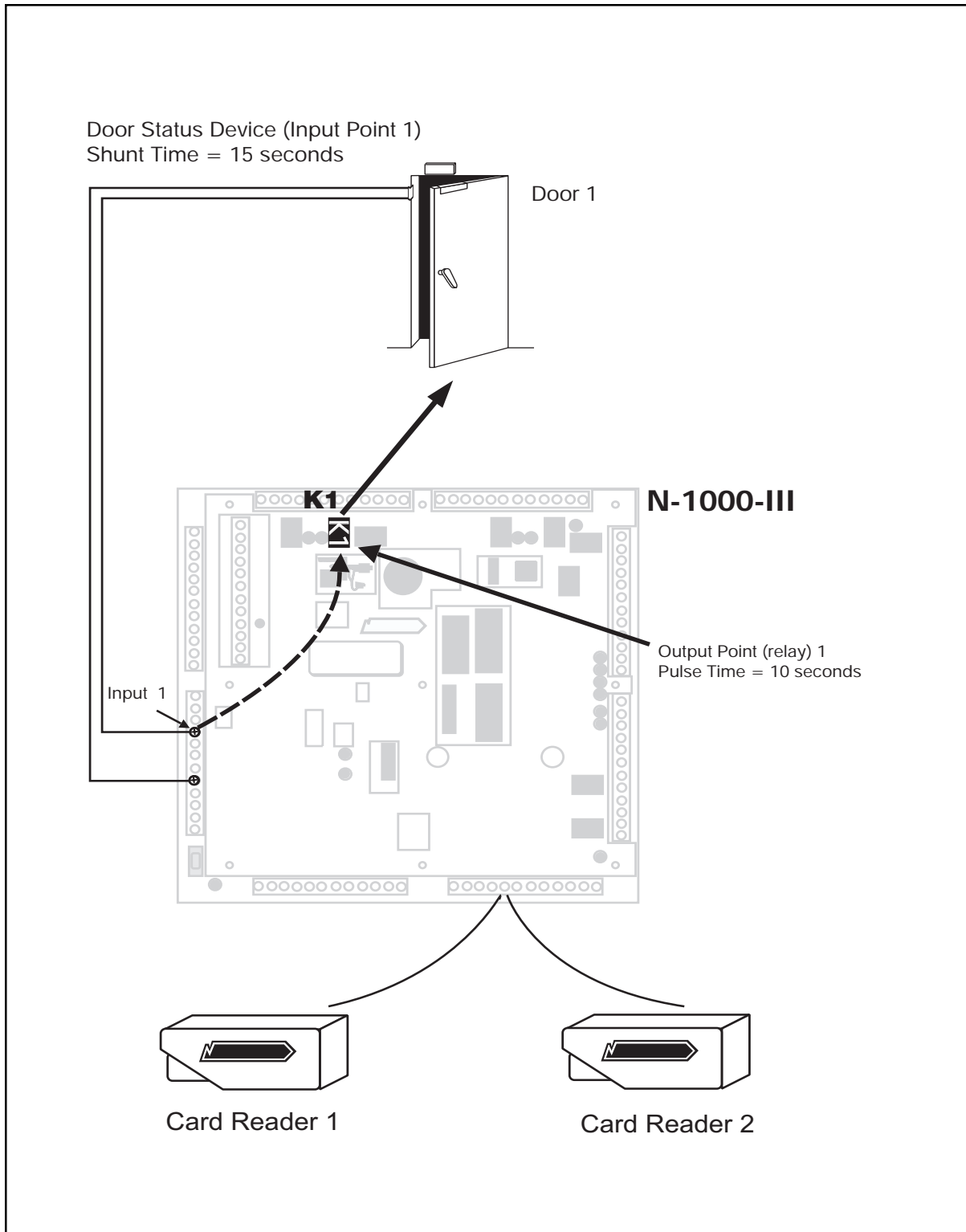

Figure 5-10. **Auto-relock with Anti-Passback.** Example: Valid code use at either card reader (or keypad) triggers the pulse time of Output Relay 1, unlocking Door 1 for 10 seconds. The activation of Output 1 triggers the shunt time of Input 1 (via the interlock), shunting Door 1 status switch for 15 seconds. Output Relay 1 de-energizes immediately upon Input 1's return to normal state, relocking Door 1 and re-arming Input 1, rather than remaining energized (shunted) for the duration of the 10 second pulse time/15 second shunt time.

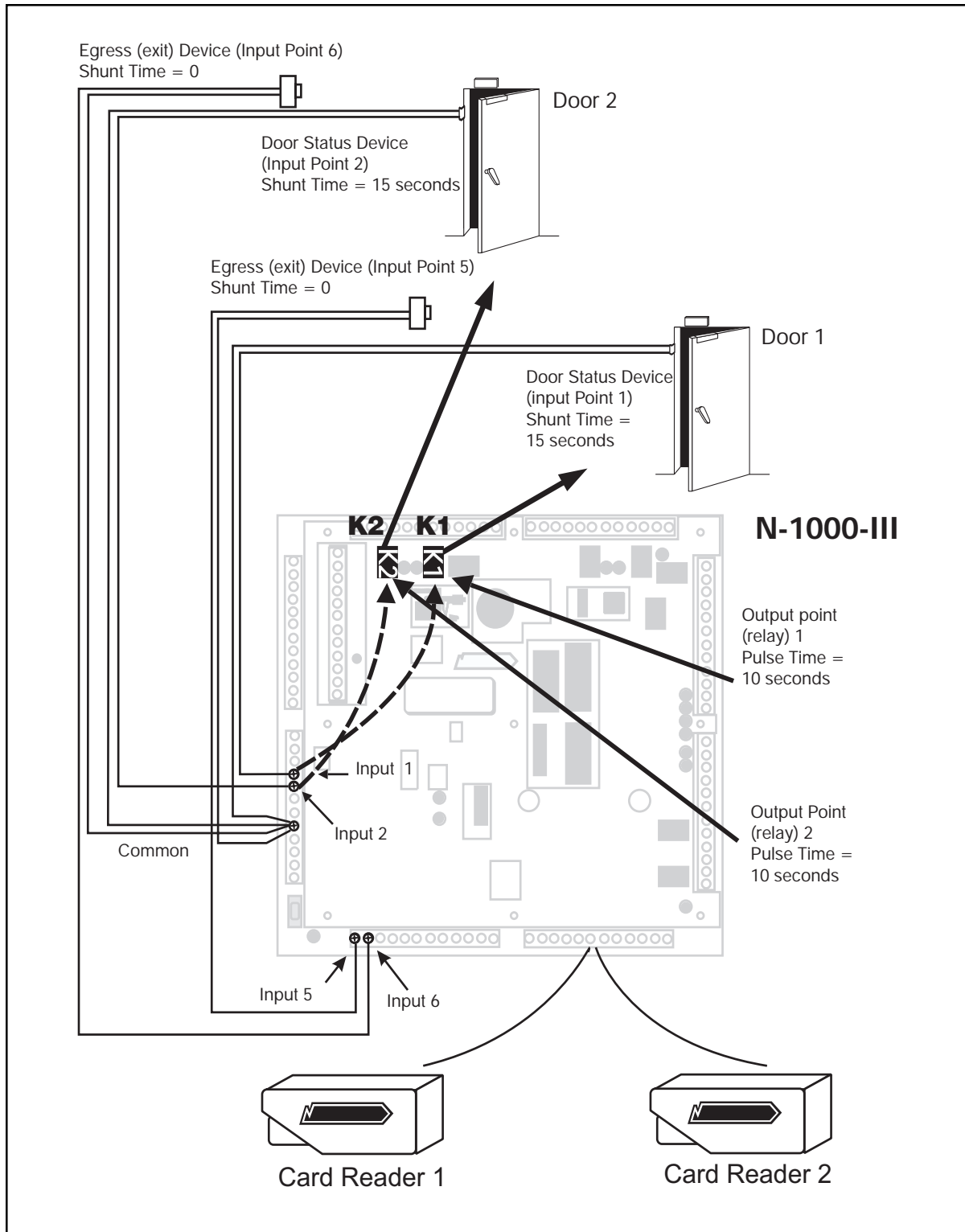

Figure 5-11. **Auto-locks Doors 1 and 2 without Anti-passback.** Output Relay 1 de-energizes immediately upon Input Point 1's return to normal state, re-locking Door 1 and re-arming Input 1, rather than remaining energized (shunted) for the duration of the 10 second pulse time/15 second shunt time. Output Relay 2 de-energizes immediately upon Input Point 2's return to normal state, re-locking Door 2 and re-arming Input 2, rather than remaining energized (shunted) for the duration of the 10 second pulse time/15 second shunt time.

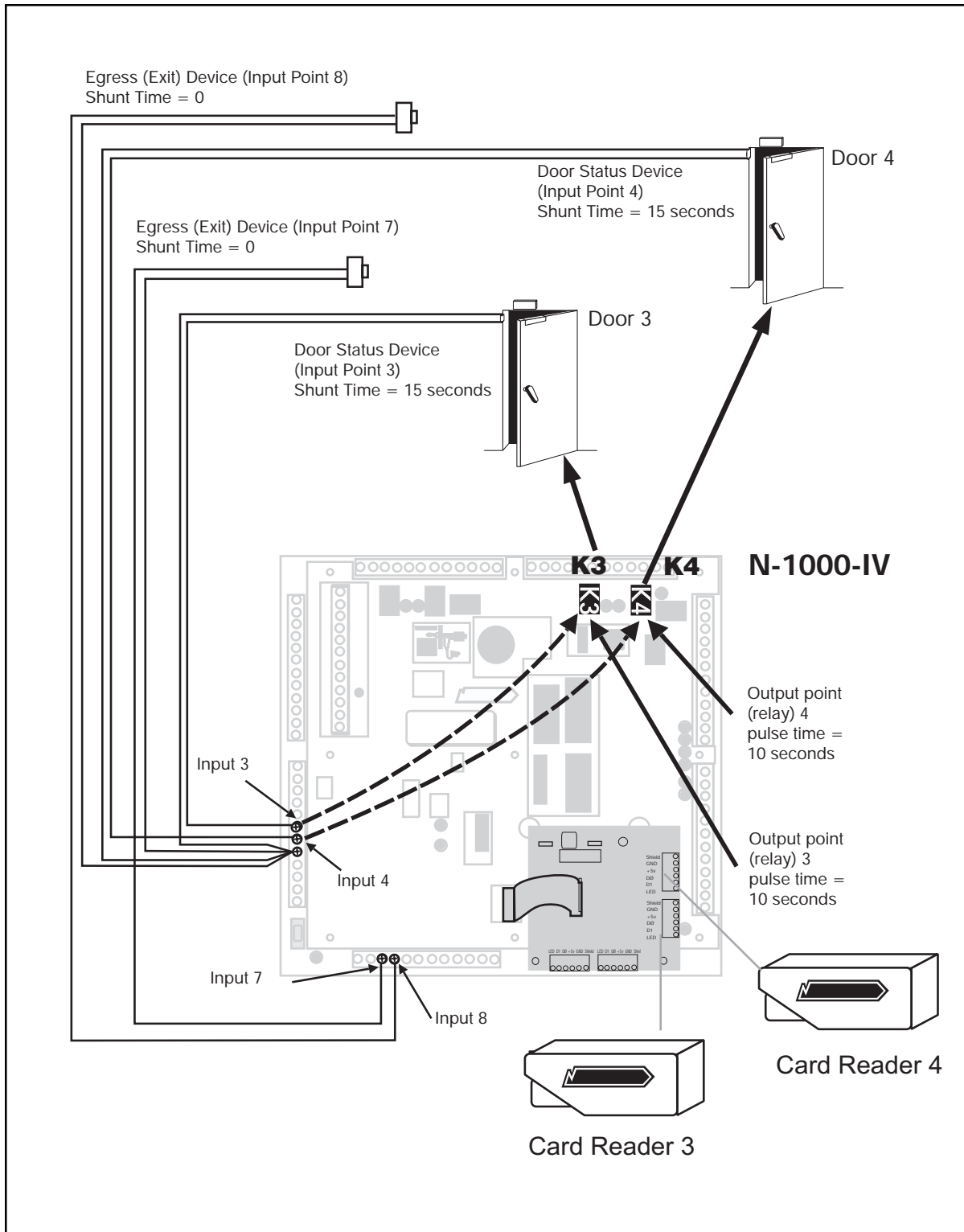

Figure 5-12. **Auto-relock Doors 3 and 4 without Anti-passback.** Output Relay 3 de-energizes immediately upon Input Point 3's return to normal state, re-locking door 3 and re-arming Input 3, rather than remaining energized (shunted) for the duration of the 10 second pulse time/15 second shunt time. Output Relay 4 de-energizes immediately upon Input Point 4's return to normal state, re-locking door 4 and re-arming Input 4, rather than remaining energized (shunted) for the duration of the 10 second pulse time/15 second shunt time.

Section 6: Wiring Requirements

6-1: Card Readers

Some card readers require that a format (software) command be programmed into the host N-1000-III/IV controller before cards can be read. When a card is run through a card reader that requires a format command, but the format command has not been programmed into the control panel, no card number is transmitted to the terminal/printer. Refer to *Appendix A* for complete F Command format listings.

N-1000-III Terminal Block 5 supports interface to two Wiegand output card readers and provides an alarm point common. Each card reader port includes terminals for LED control, Data 1 signal, Data 0 signal, + 5 VDC output and Ground. See Figure 6-1 for typical wiring diagram.*

Card reader/keypad communication shields should be connected to TB5 position 12. The shield at the card reader/keypad end should not be grounded unless the device is electrically floating (not touching metal). (See Figure 6-1.)

Typical Card Readers using Reader Cable NC1861 or for Plenum applications NCP1861 have the following terminations (maximum distance is 500' or 152 m). Refer to documentation included with your reader for the latest information. (Cable specifications and part numbers are listed at the end of this section.)

Reader 1:

Terminal

Block	Terminal	Function	Reader Wire Color
5	1	LED (Aux. Output 11)	Brown
5	2	Data 1	White
5	3	Data 0	Green
5 (or 9)	4 (or 7)	+ 5 VDC (+ 12 VDC)*	Red
5	5	Ground	Black
	–	Not used	Blue
5	12		Shield

Reader 2:

Terminal

Block	Terminal	Function	Reader Wire Color
5 (or 9)	4 (or 7)	+ 5 VDC (+ 12 VDC)*	Red
5	5	Ground	Black
5	6	Data 0	Green
5	7	Data 1	White
5	8	LED (Aux. Output 12)	Brown
	–	Not used	Blue
5	12		Shield

*+ 12 VDC 500 mA power is available on Terminal Block 9 position 7. Use TB5 terminal 4 **OR** TB9 terminal 7 **NOT BOTH**.

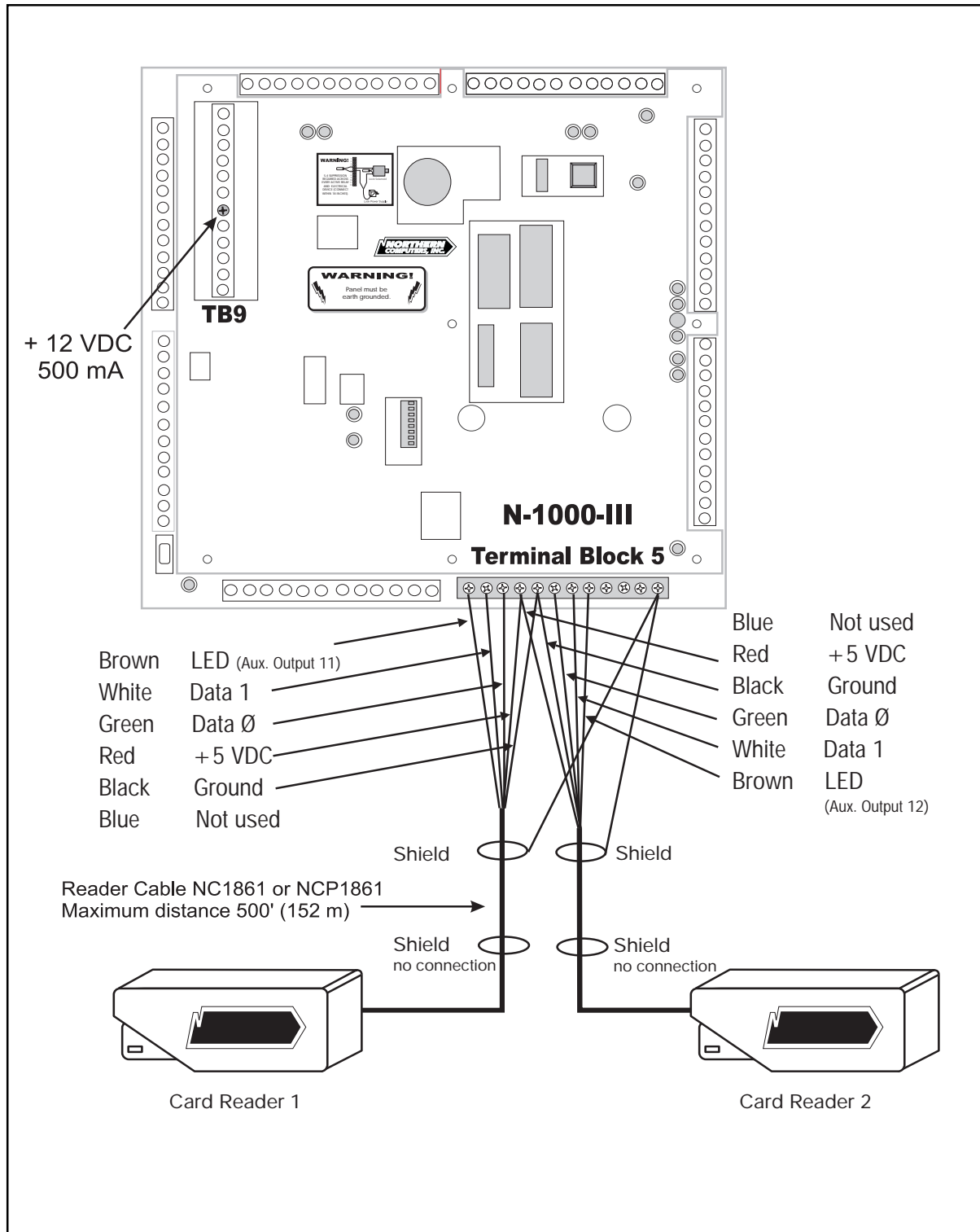

Figure 6-1. Card Reader Connections to TB5. N-1000-III Terminal Block 5 supports interface for two Wiegand output card readers and provides an alarm point common. Each card reader port includes terminals for LED control, Data 1 signal, Data Ø signal, +5 VDC output and Ground. +12 VDC power is available on Terminal Block 9 position 7. Card reader/keypad communication shields should be connected to TB5 position 12. The shield at the card reader/keypad end should not be grounded unless the device is electrically floating (not touching metal).

6-2: Four Reader Board (N-1000-IV Only)

The N-1000-IV includes a board that supports up to four card readers. The wiring terminal blocks are removable and interchangeable. No connections should be made to the TB5 terminals of the main board when the Four Reader Board is connected. (See Figure 6-2.)

If a reader requires 12 VDC, power can be obtained from TB9 terminal 7. The electrical load on TB9 terminal 7 must not exceed 500 mA. If the combined reader current draw exceeds 500 mA, a separate power supply should be used. Refer to the Readers' Technical Bulletin for the wiring details.

Reader 1, 2, 3, 4:

Terminal	Function	Reader Wire Color
1	LED (Aux. Output 11)	Brown
2	Data 1	White
3	Data Ø	Green
4 (TB9-7)	+ 5 VDC (+ 12 VDC)*	Red
5	Ground	Black
-	Not used	Blue

*+ 12 VDC power is available on Terminal Block 9 terminal 7. Use connection 4 or TB9 terminal 7 **NOT BOTH**.

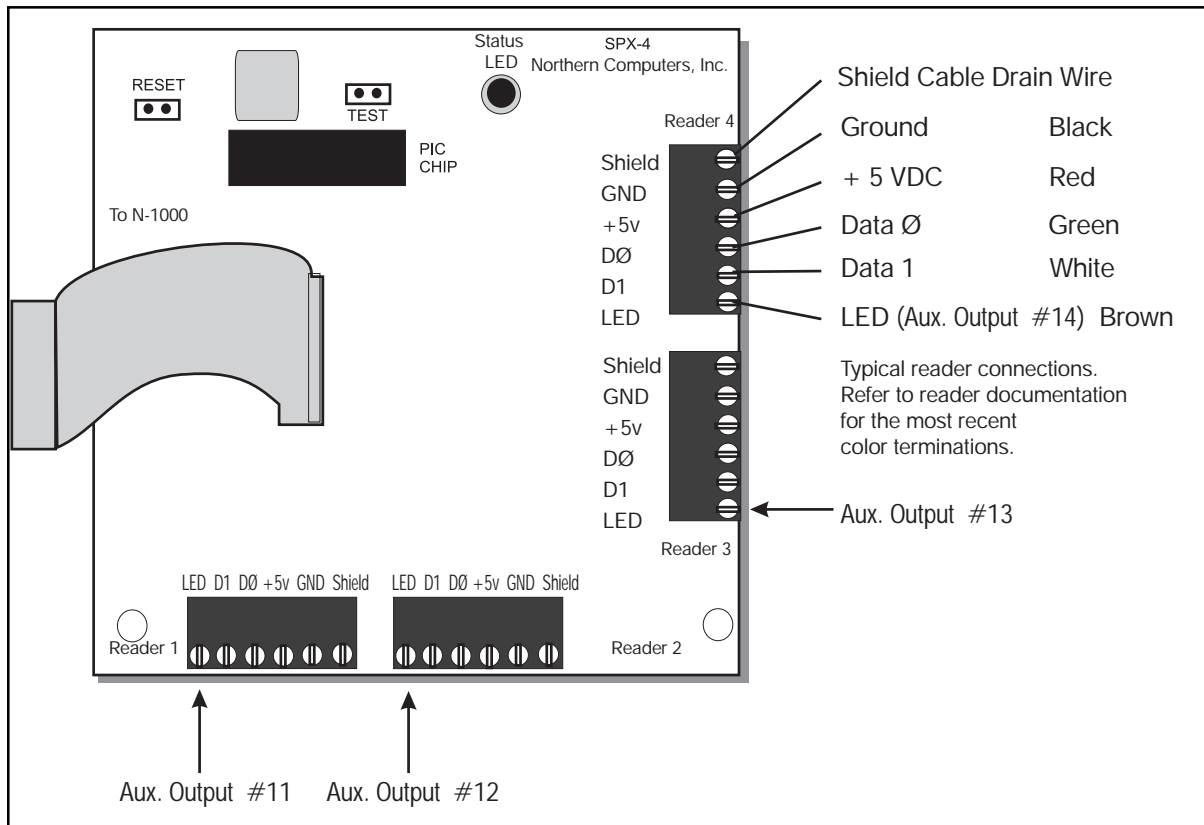

Figure 6-2. **Card Reader Connections for the N-1000-IV.** The N-1000-IV includes a board that supports up to four card readers. The wiring terminals are removable and interchangeable. No connections should be made to the TB5 terminals of the main board when the Four Reader Board is connected.

On the N-1000-IV, card reader/keypad communication shields should be connected to the panel at the shield position on the Four Card Reader wiring blocks. The shield at the card reader/keypad end should not be grounded unless the device is electrically floating (not touching metal). (See Figure 6-3.)

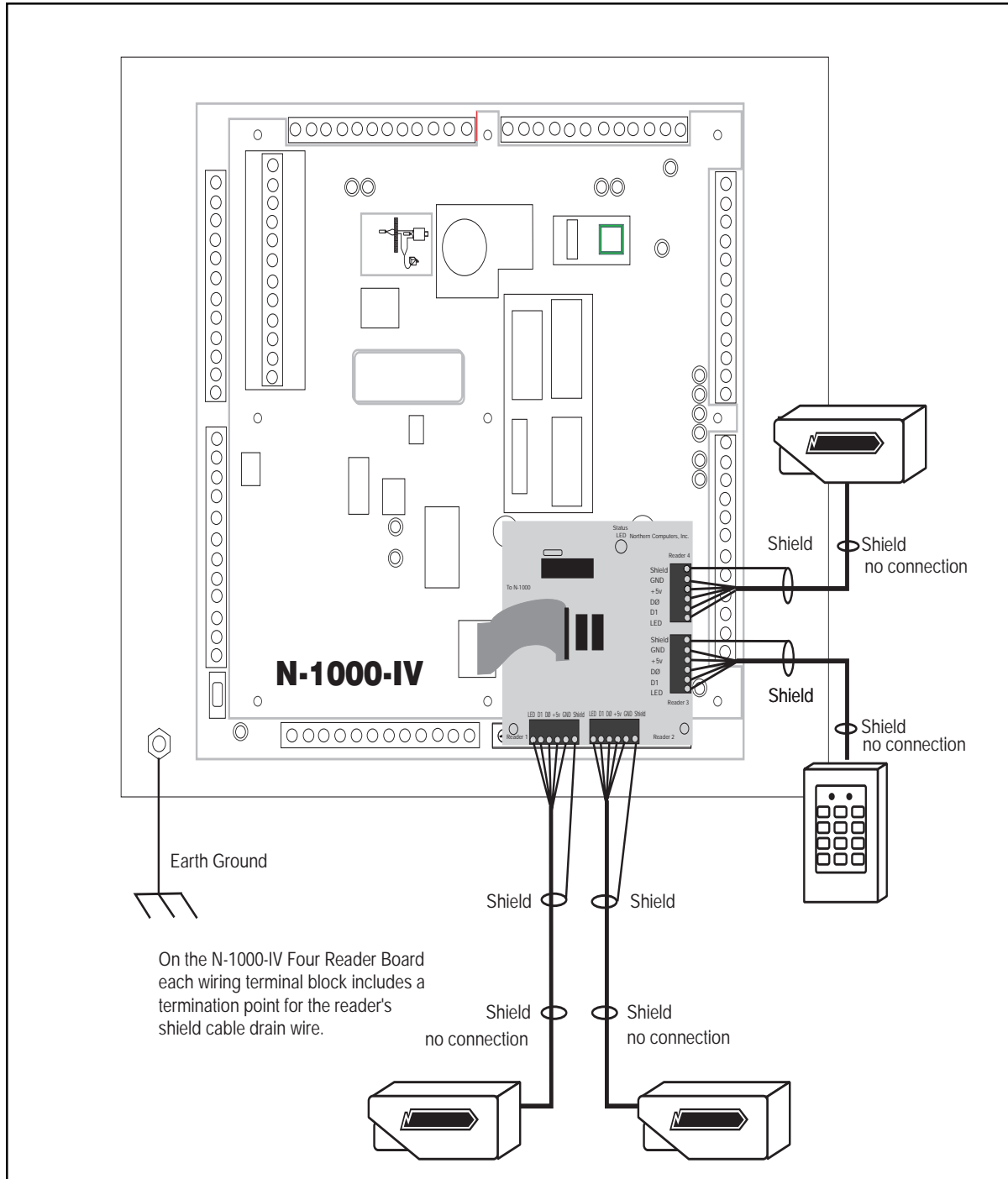

Figure 6-3. Card Reader/Keypad Grounding N-1000-IV. Card reader/keypad communication shields should be connected to the panel at wiring block position 5. The shield at the card reader/keypad end should not be grounded unless the device is electrically floating (not touching metal).

6-3: Eleven Conductor Keypads

A typical Eleven Conductor Keypad uses a 2 of 7 matrix configuration where each keypad row and column corresponds to a unique wire (Figure 6-4). When a key is pressed, two of seven wires are activated (two of the wires are put to ground); one wire corresponds to the key's row and one wire corresponds to the key's column. For example, if the 3 button is pressed, the gray (row 1) and green (column 3) wires are activated (put to ground). If the 8 button is pressed, the yellow (row 3) and blue (column 2) wires are activated (put to ground).

Typical eleven conductor keypads, using Keypad Cable NC18121 or for Plenum applications NCP18121 (maximum distance is 500' or 152 m), have the following terminations (See Figure 6-5):

Keypad 1			Keypad 2		
TB	Terminal	Wire Color	TB	Terminal	Wire Color
8	1	Brown	8	1	Brown
8	2	Blue	8	2	Blue
8	3	Green	8	3	Green
8	4	Black	8	4	Black
8	5	Gray	8	5	Gray
8	6	Purple	8	6	Purple
8	7	Yellow	8	7	Yellow
8	8	Orange	8	8	Orange
8	9	Peach/Pink	8	9	Peach/Pink
8	10	White	8	11	White
5	4	Red	5	4	Red

Refer to your keypad technical documentation for the latest information.

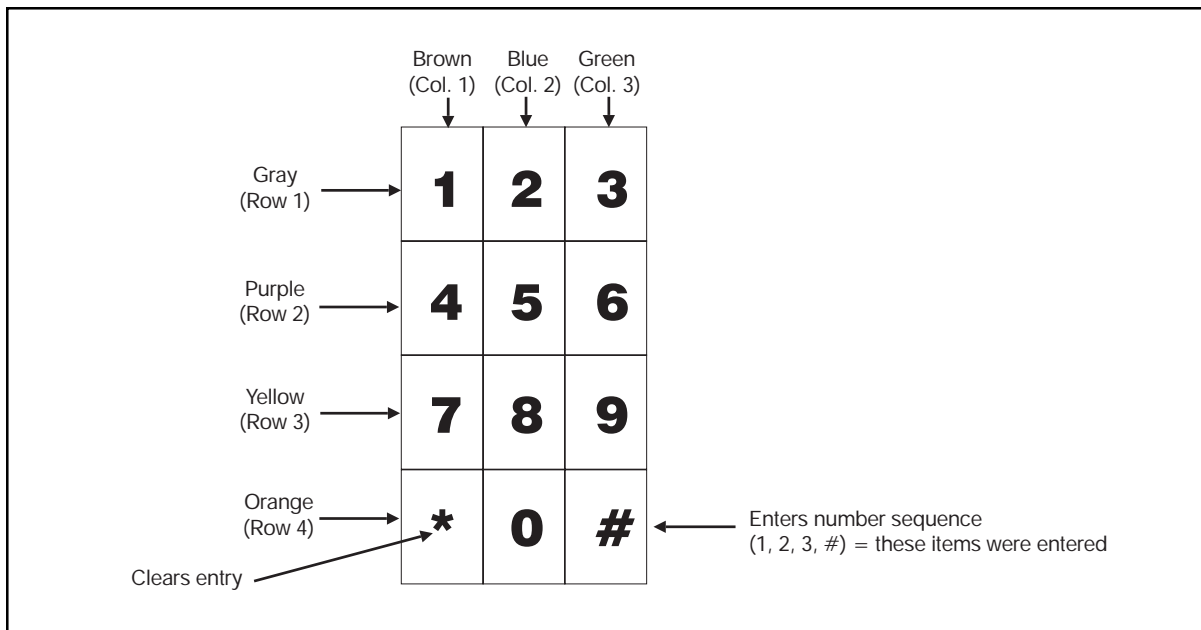

Figure 6-4. **Eleven Conductor Keypad 2 of 7 Matrix.**

Tan Earth Ground wire connections (Not used on all keypads).

If the keypad is mounted directly on grounded metal, tie the tan wire to the grounded metal and tie the keypad cable shield to the N-1000-III/IV grounding point (float shield at keypad).

If the keypad is mounted on ungrounded metal or nonmetallic material, tie the tan wire to the keypad cable's shield only and connect the shield to the N-1000-III/IV ground point.

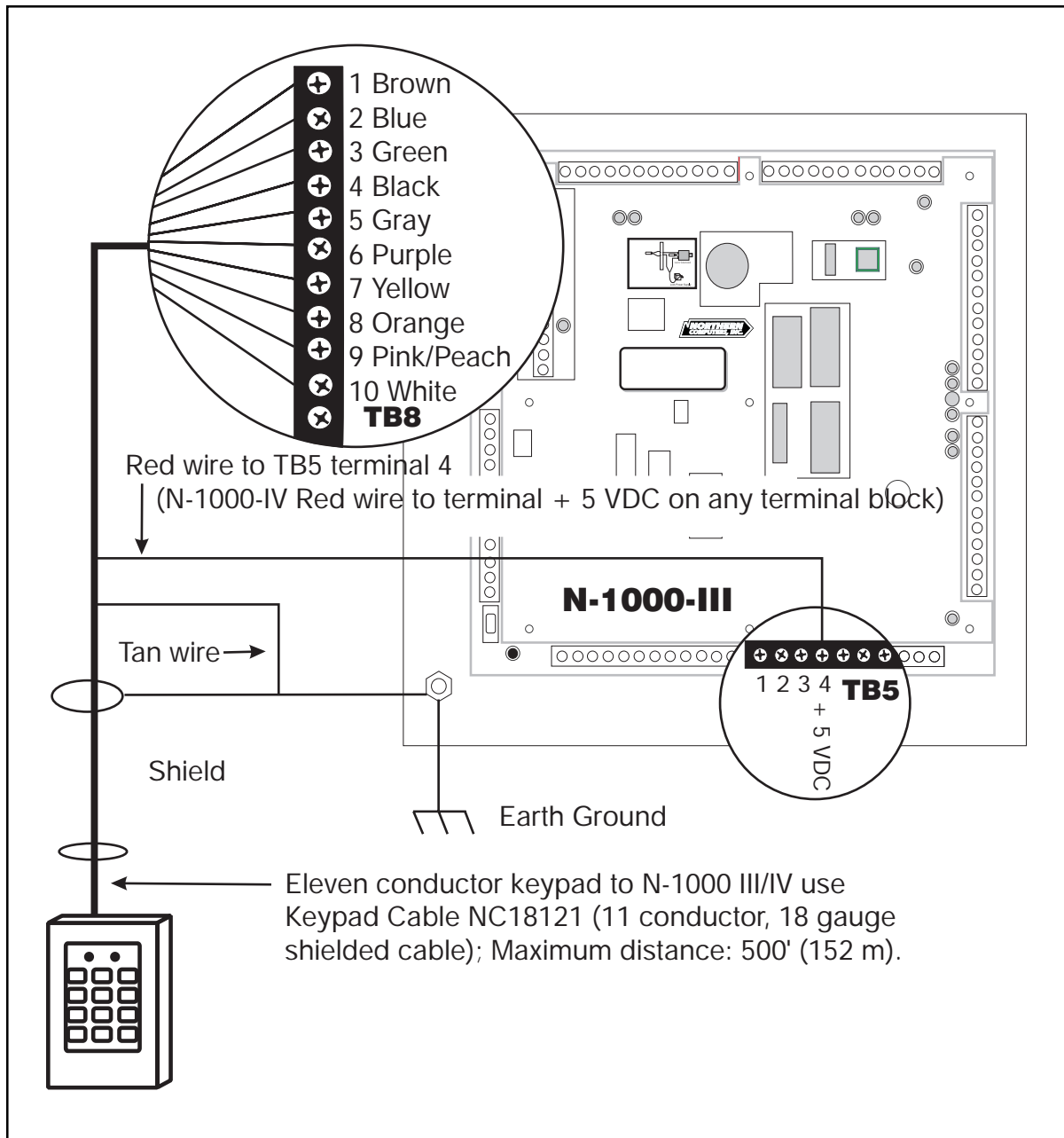

Figure 6-5. **Eleven Conductor Keypad Connection to the N-1000-III/IV.** *If the keypad is mounted on ungrounded metal or nonmetallic material, tie the tan wire to the keypad cable's shield only and connect the shield to the N-1000-III/IV ground point.*

6-4: Alarm Input Points

Panel/communication cable NC1821/NCP1821 (twisted, 18 gauge overall shielded cable) is recommended for alarm input point use. This enables the input device to be located up to 2000 feet (610 m) away from the N-1000-III/IV.

Connect the shield to the panel's earth ground and leave the other end of the shield not connected.

All N-1000-III/IV alarm point commons are electrically the same and can be used with any panel alarm point. Refer to terminal block diagrams in Section 4 for alarm point common locations.

If end of line (EOL) resistors are used for supervised inputs, then they must be located at the switch in order to be effective.

Refer to *Appendix A* for a summary list of specific alarm input point commands.

6-5: Relay Output Points

Panel/communications cable NC1821/NCP1821 (twisted pair, 18 gauge, overall shielded) is recommended for relay output point use. This enables the output device to be located up to 2000 feet (620 m) away from the N-1000-III/IV. An 18 gauge wire's resistance results in a 6.5 volt drop for a quarter ampere load at 2000 feet.

Refer to *Appendix A* for a summary list of specific relay output point commands.

6-6: Communications

6-6-1: PC to C-100-A1

Cable CBL-2 (three conductor, 18-20 gauge) is recommended for use between the PC and the C-100-A1 Converter. This enables the C-100-A1 to be located up to 50 feet (15 m) away from the CPU (See Figure 6-6).

6-6-2: C-100-A1 to Panel(s)

Panel/communications cable NC1821/NCP1821 (twisted pair, 18 gauge shielded) is recommended, enabling runs of up to 2000 feet (610 m), for each of the following:

- C-100-A1 to first panel in communication loop.
- Panel to panel.
- Last panel in communication loop to C-100-A1. (See Figure 6-6.)

The 20 mA communications loop for the C-100-A1 and the N-1000-III/IV operate using active-transmit and passive-receive. The Communications Type Selection Jumper JP1 must be set to the 20 mA (default) position 1 & 2.

In a single panel 20 mA communication loop, ground the communication cable shield only at the panel, as shown in Figure 6-8.

In a multiple 20 mA panel communication loop, the 20 mA communication cable shield between any two given panels in the loop should be grounded at one end only. Ground either the receive side *or* the transmit side of the shield (*not both*), giving care to be consistent throughout the loop. *The receive side grounding method is preferred* (see Figure 6-9). The transmit side grounding method is not recommended.

6-6-3: AEP-3 to N-1000-III/IV

Up to two AEP-3 Relay Expansion Boards per N-1000-III/IV panel can be added to the communication loop. Using the cable supplied with the unit, one AEP-3 connects to the N-1000-III/IV at J1, and then to the next AEP-3. (See Figure 6-10.) Refer to the AEP-3 manual for further details.

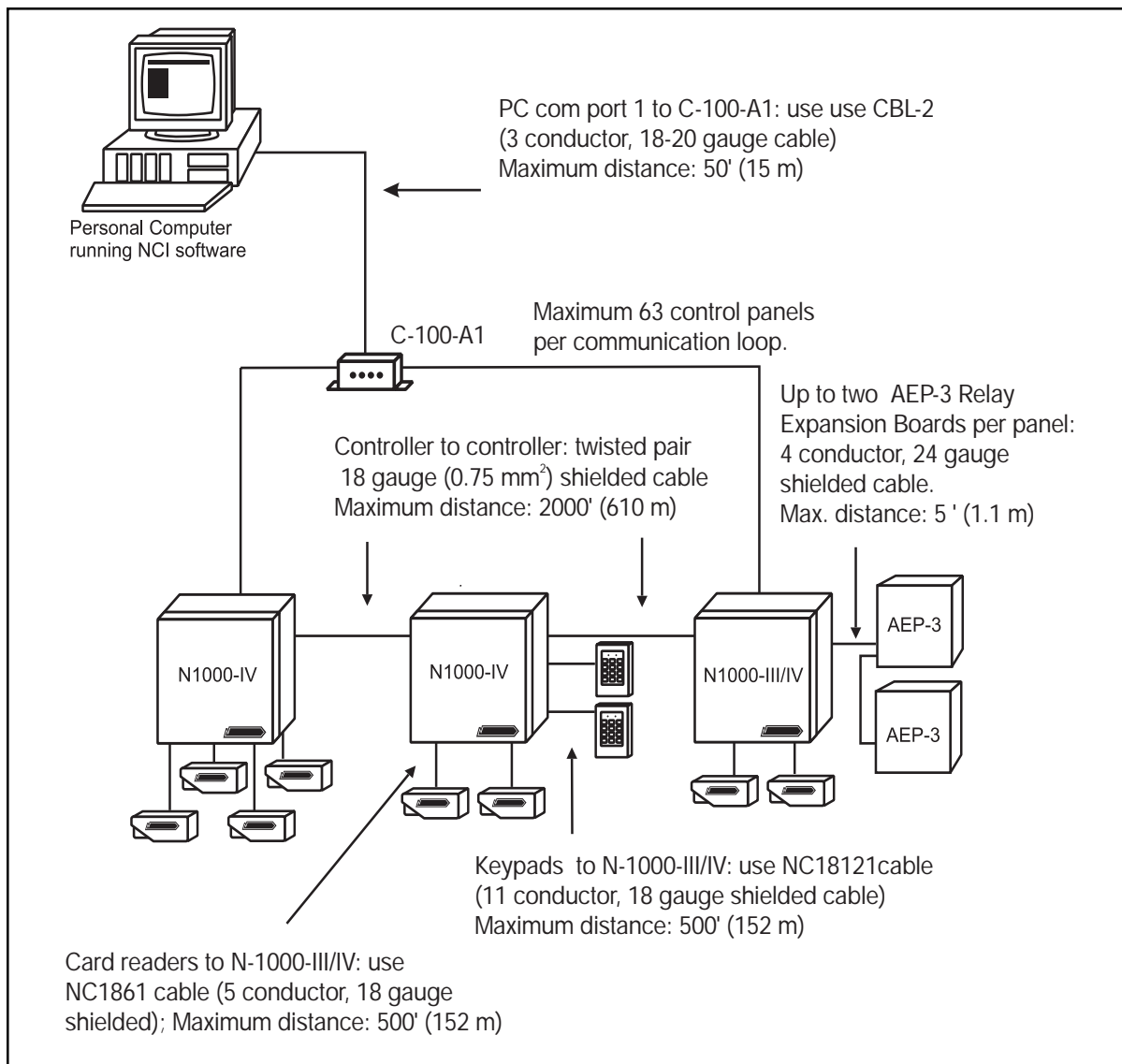

Figure 6-6. **Typical 20 mA Communication Loop.** See Figure 6-10 for AEP-3 connections.

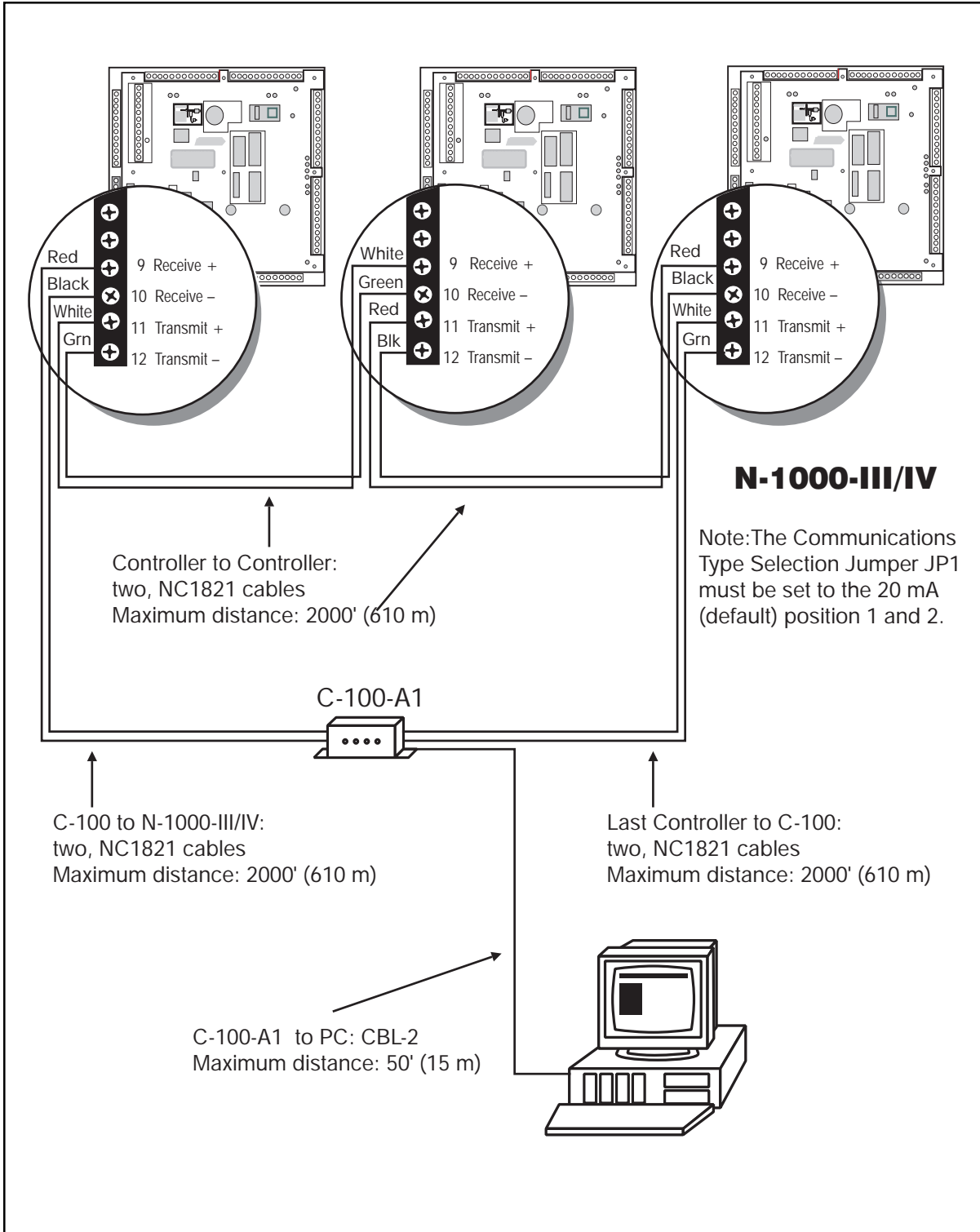

Figure 6-7. Typical C-100-A1 Multiple Panel 20 mA Communication Loop. Refer to Figure 6-9 for grounding of the communication loop. The Communications Type Selection Jumper JP1 must be set to the 20 mA (default) position 1 & 2.

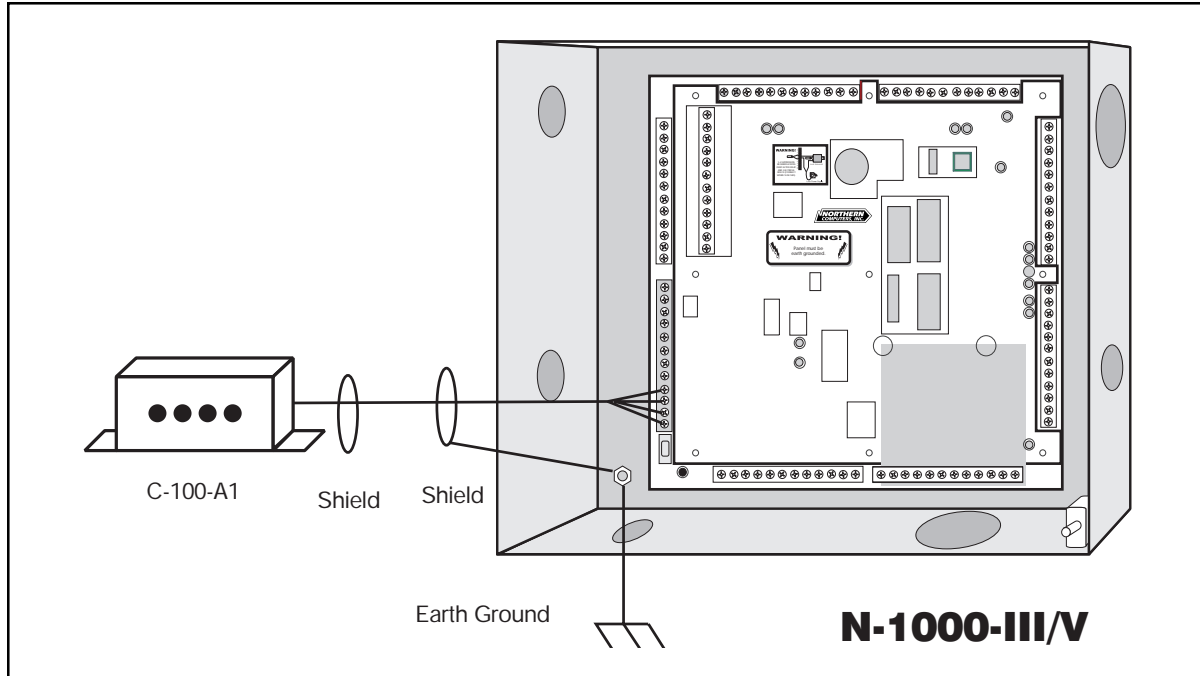

Figure 6-8. **Grounding a Single Panel, 20 mA Communication Loop.** In a single panel 20 mA communication loop, ground the communication cable shield only at the panel.

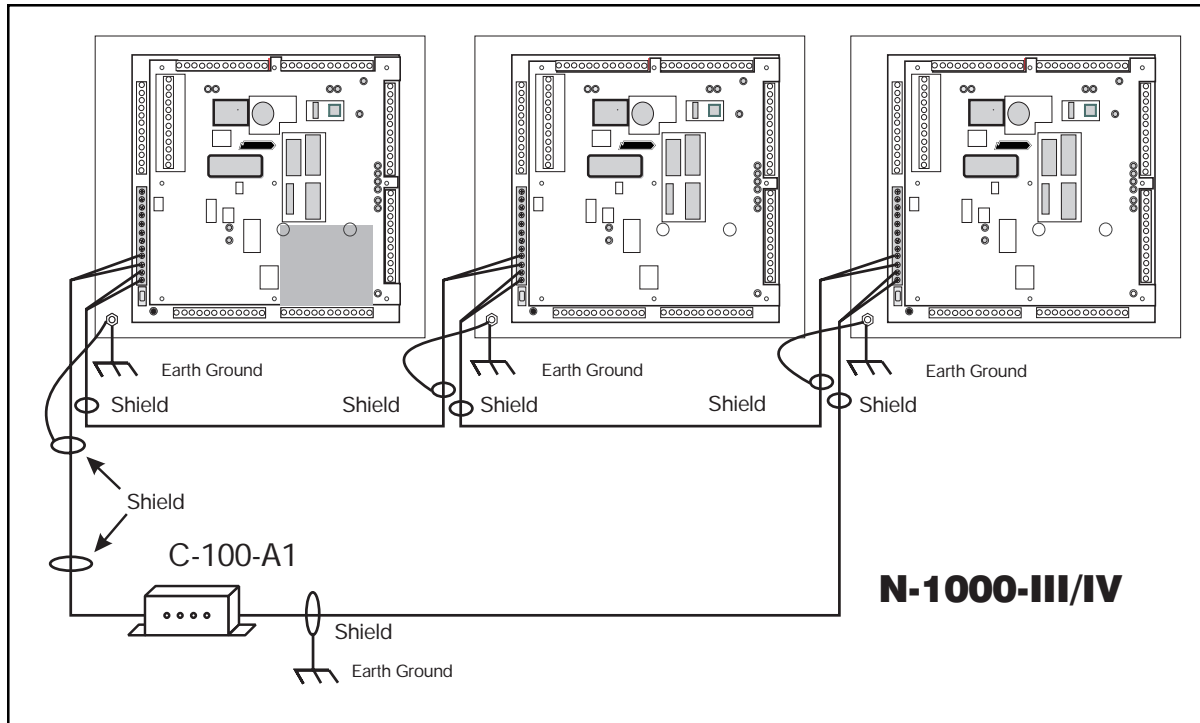

Figure 6-9. **Grounding a Multiple Panel, 20 mA Communication Loop.** In a multiple 20 mA panel communication loop, the 20 mA communication cable shield between any two given panels in the loop should be grounded at one end only. The preferred receive side grounding method is shown here. The transmit side grounding method is not recommended.

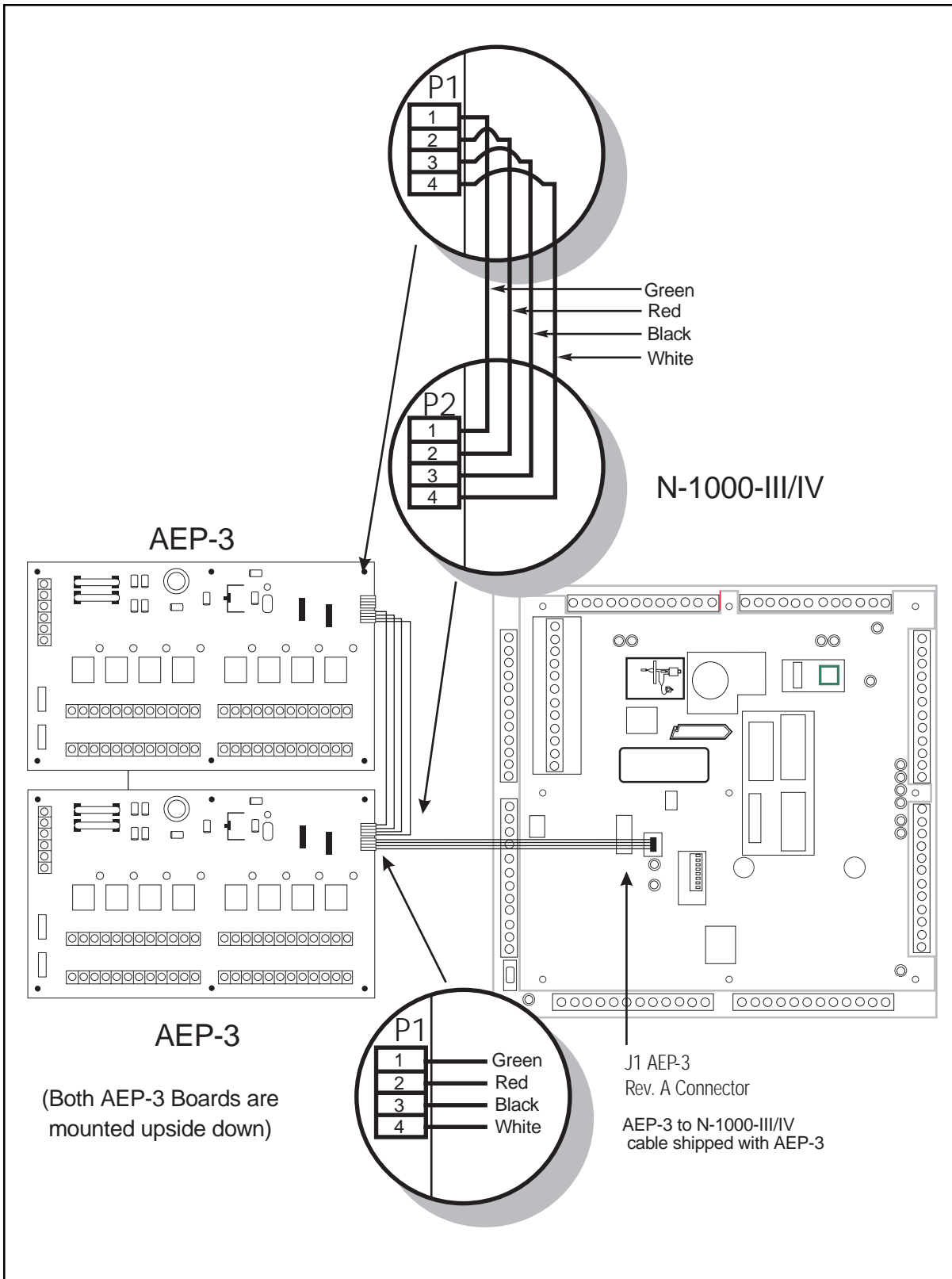

Figure 6-10. **Connecting an AEP-3 Relay Expansion Board.** The AEP-3 Relay Expansion Board is shipped with a cable. It connects to the N-1000-III/IV panel at J1. The next AEP-3 Expansion Board connects to the first as shown above. See the AEP-3 manual for further details.

6-6-4: PC to N-485-PCI-2

The N-485-PCI-2 uses a 9 pin female connector which will plug into a standard 9 pin serial port on the PC. If the PC is configured for use with a serial expansion device, an adaptor cable or shell may be required. Refer to the N-485-2 Adapter Installation Guide (TD1077) for proper configuration. Figure 6-11 shows a typical configuration with an N-485-PCI-2 at one end of the line and a panel at the other end.

6-6-5: N-485-PCI-2 to Panel

The NC2021/NCP 2021 cable is recommended (twisted pair, 24 gauge overall shielded cable with a characteristic impedance of 120 ohms and a capacitance of 20 pf/ft. (or lower) should be used). Consult the device installation guide for cable lengths and configurations.

The Communications Type Selection Jumper JP1 must be set to the RS-485 position 2 & 3. For proper communication, jumpers JP2, JP3 and JP4 must also be properly configured on each panel. Refer to *Section 6-6-8* and Figure 6-13 for details.

For 485 multi-drop communications, the shield should be connected at both ends and **only** to the screw terminals labeled *485 Shield* as in Figure 6-14. The shield should be tied to the earth ground only at the PCI or HUB.

For a typical configuration using the N485DRLA Digital Redundant Loop Adapter see Figure 6-15.

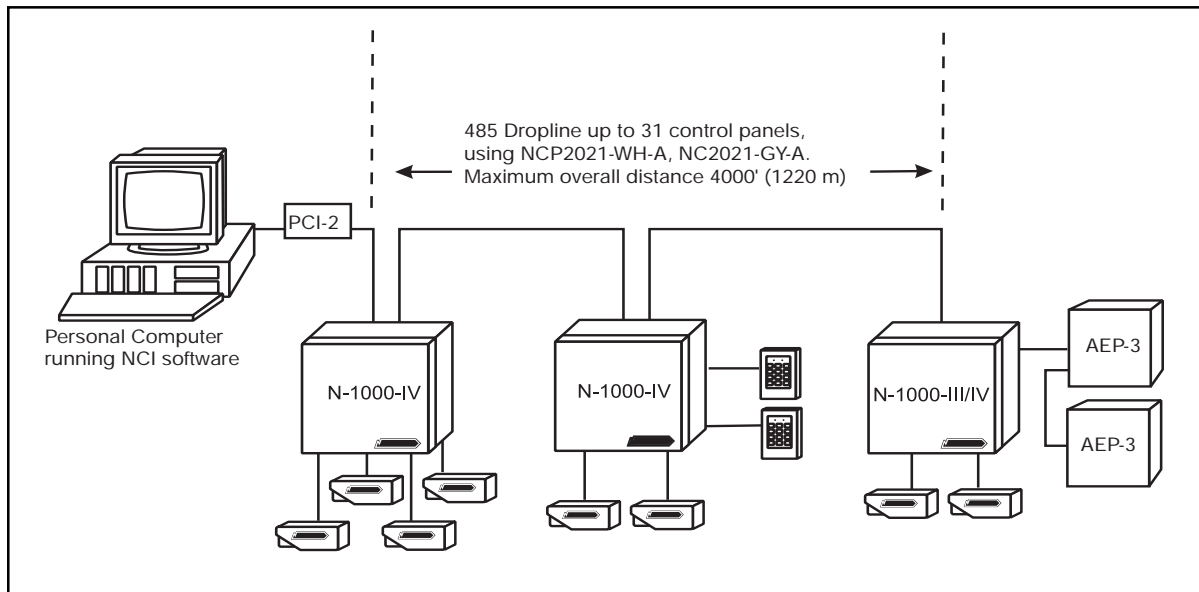

Figure 6-11. **Typical N-485 Multi-drop Configuration.** This is a typical configuration with an N-485-PCI-2 at one end of the line and a panel at the other end. The AEP-3 is connected to the N-1000-III/IV at J1. See Figure 6-10 for details of the AEP-3 connection.

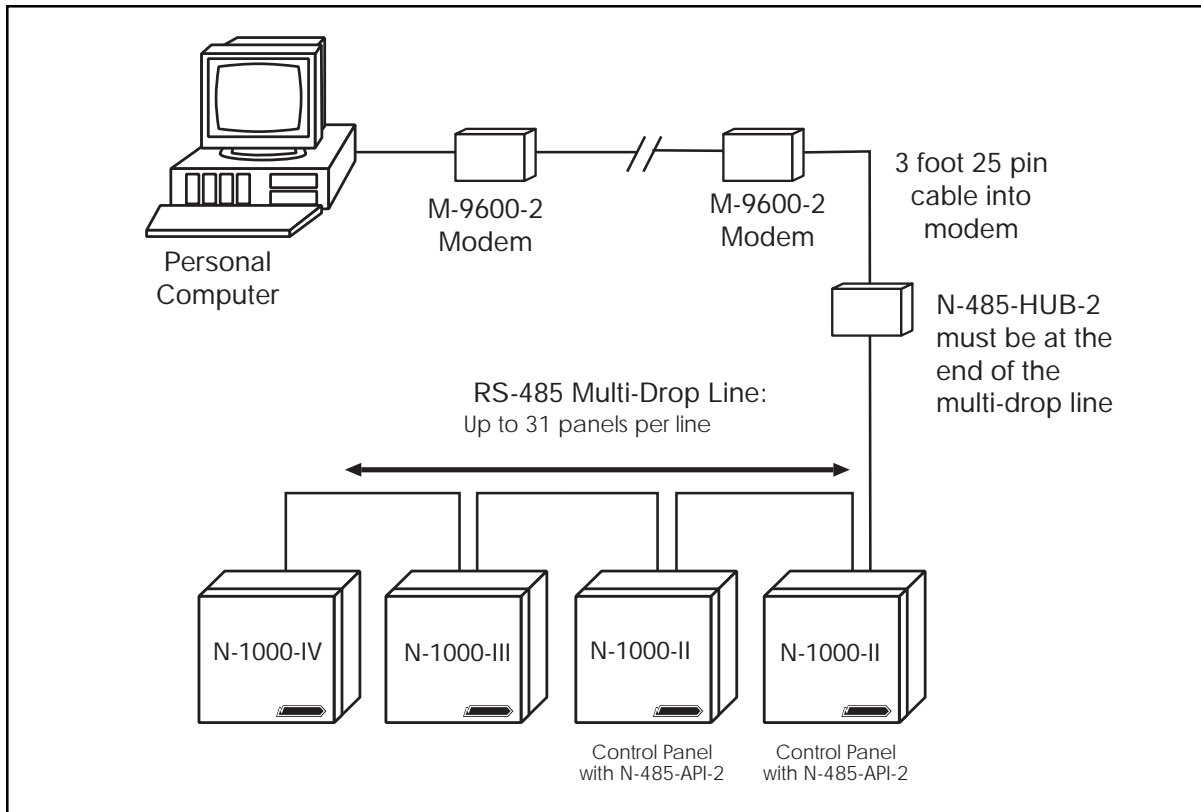

Figure 6-12. **Typical N-485 Multi-drop Configuration.** This is a typical configuration using an N-485-HUB-2 and modems and mixed N-1000 panels.

Note: When mixing N-1000-II panels with the N-1000-III/IV in an N-485 dropline, the N-485-API-2 panels must have the same version (1.xx, 2.xx...) as the N-1000-III/IV panel's 485 EPROM.

The dropline must be terminated at the ends. No other termination should be used at the panels which are not located at the ends.

For proper configuration of the N-1000-II in mixed loops, refer to the manuals for N-485-API-2, N-485-PCI-2, and N-485-HUB-2.

6-6-6: N-485-HUB-2 to Panel

The same cable should be used as the connection between the N-485-PCI-2 and the panels. The Communications Type Selection Jumper JP1 must be set to the RS-485 position 2 & 3. Figure 6-12 shows a typical configuration with a HUB using modems.

6-6-7: N-485-HUB-2 to Modem

The N-485-HUB-2 includes a DB-25 male connector, with a three foot long cable, to plug directly into the modem.

6-6-8: Bias and EOL with 485 Communication

Bias voltage, provided by “pull up/down” resistors (bias resistors), is required for the greatest clarity in 485 transmissions. At least one bias resistor must be connected to a given drop line. In addition there must be an end of line resistor (EOL) at both ends of the copper wire on a drop line for units to function efficiently.

Bias and EOL resistors are built into the N-1000-III/IV panel, the PCI, HUB and API units. On the PCI and HUB, bias and EOL are present on the line when the green/white wires are attached. With the API, bias and EOL are present when proper attachments are made to pins 1 and 2 on TB2 (Refer to TD1077, N-485 Communication Adaptor Installation Guide that comes with the N-485-API-2.)

The N-1000-III/IV can provide bias for the PCI, HUB and API units when they are not at the end of the line. Bias and EOL resistors on the N-1000-III/IV are attached by using the proper jumper settings. Setting JP2 and JP3 on provides both bias and EOL, while setting JP4 on provides EOL only. When JP2 and JP3 are on, JP4 must be off.

Refer to Figure 6-13 for examples of bias and EOL.

Rule of Thumb for end of line termination (EOL).

1. EOL at both ends of copper.
2. Only one N-1000-III/IV panel, PCI, HUB or API provides 485 line bias. Bias is provided when the green/white wires are used on the PCI and HUB, when attachments are made to pins 1 and 2 on TB2 on the API or when JP2 and JP3 are used on the N-1000-III/IV panel. JP4 must not be used at the same time as JP2 & JP3.

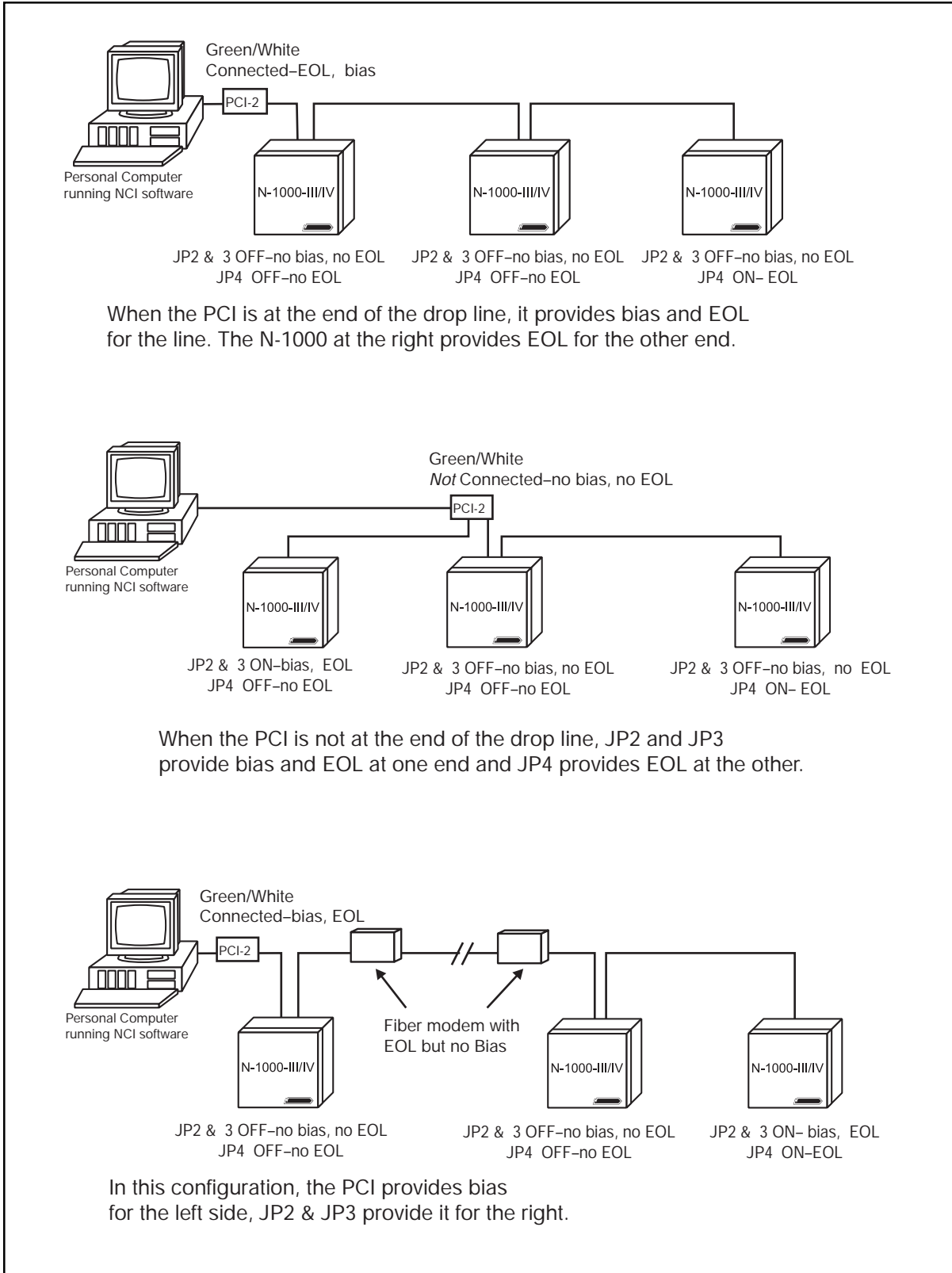

Figure 6-13. 485 Multi-drop Bias and EOL If the N-485-PCI-2 (or HUB-2) is wired between two panels and not at the end of the multi-drop communications wiring, terminate the last panel at one end only with JP 2 and JP 3 inserted and JP 4 off.

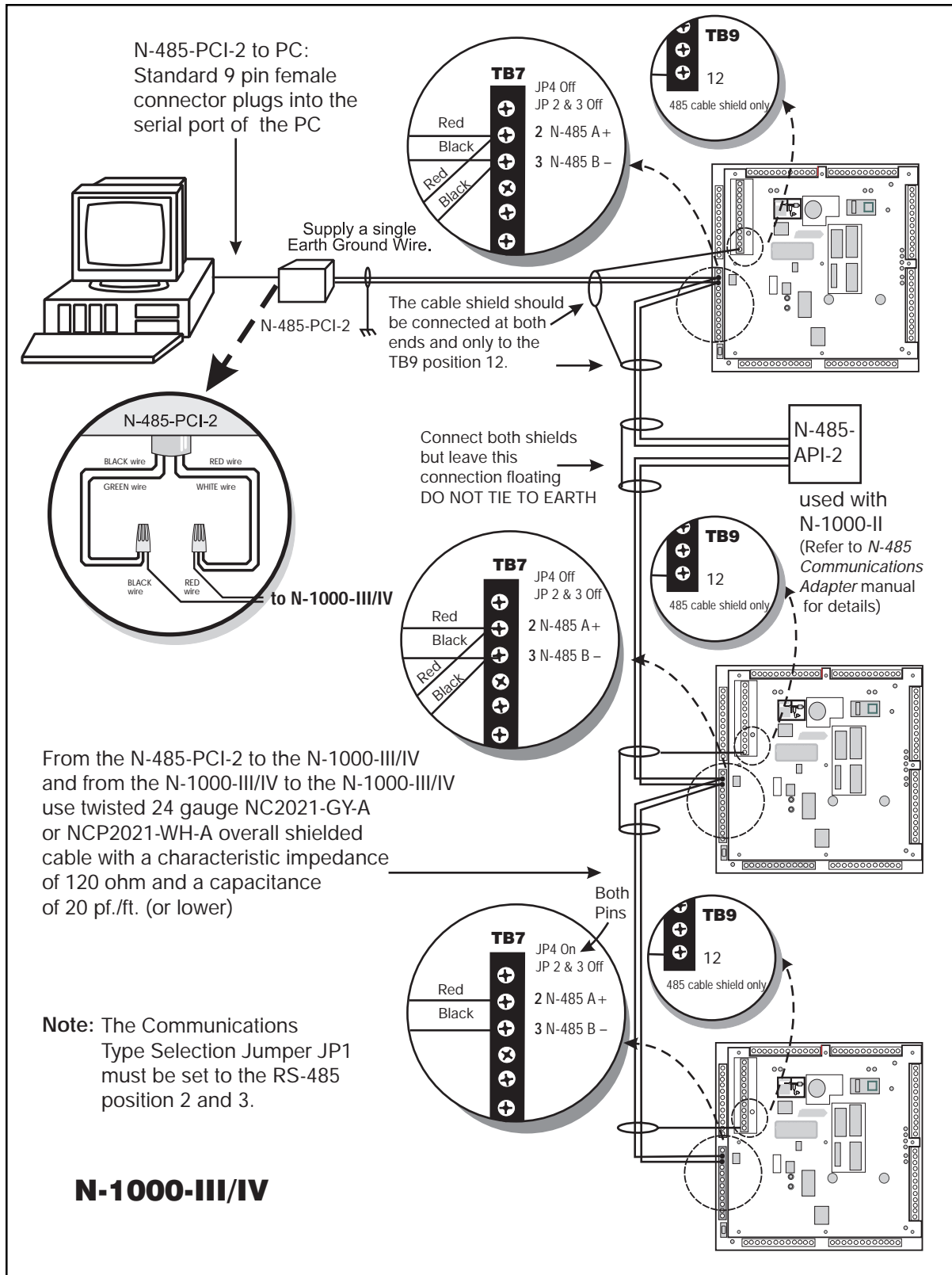

Figure 6-14. 485 Multi-drop Connection with Shielded Cable. A 485 communication loop with a PCI at the end of the line.

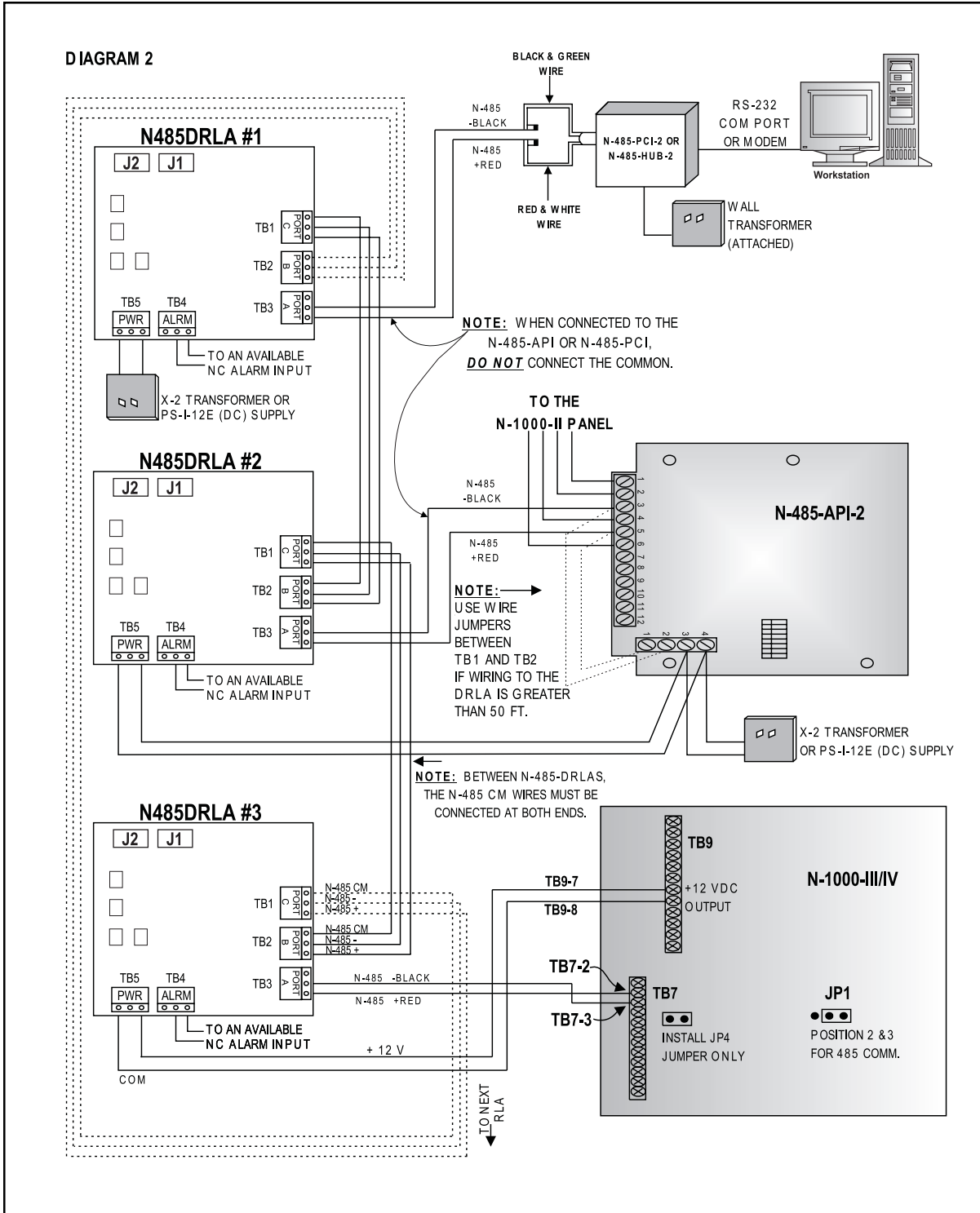

Figure 6-15. **485 Multi-drop Connection with N485DRLA.** The N-485-DRLA Digital Redundant Loop Adapter provides an alternate communications route in the event that wiring is cut or a short circuit. Also, the signal is amplified at each node, allowing longer wiring distances. A minimum of three DRLAs are required.

6-7: Cable Specifications

<i>Application</i>	<i>NCI Part No.</i>	<i>AWG</i>	<i>Description</i>	<i>Max. Dist.</i>	<i>Imp.</i>	<i>Cap.</i>
CPU to C-100-A1	CBL-2	N/A	9-25 pin adapter	6' (1.8 m)		
C-100-A1 to controller, controller to controller, controller to C-100-A1	NC1821-GR	18	twisted pair, shielded	2000' (610 m)		
N-485 connections	NC2021-GY-A or NCP2021-WH-A	N/A N/A	twisted pair, shielded 2 conductor	4000' (1200 m)	120 Ω	20pf/ft
N-1000-II to AEP-3				5' (1.1 m)		
CR-1, TR-1, CI-1, KR-1 Wiegand card readers	NC1861-BL	18	6 conductor shielded	500' (152 m)		
NR-1 magstripe reader	NC1861-BL	18	6 conductor shielded	500' (152 m)		
PR-1-280 Cotag reader: 280 read head to SZC SZC to N-1000-II	NC1861-BL NC1861-BL	18 18	6 conductor shielded 6 conductor shielded	300' (91 m) 500' (152 m)		
PR-2 Hughes reader: scanner to reader reader to N-1000-II	NC1861-BL NC1861-BL	18 18	6 conductor shielded 6 conductor shielded	30' (9 m) 500' (152 m)		
PR-3, PR-5 Indala readers: A-3/A-5 read head to RE-2	NC18121-YL NC1861-BL	18 18	12 conductor shielded 6 conductor shielded	75' (23 m) 500' (152 m)		
PR-20 , PR-22 Indala readers: A-20/A-22 read head to RE-2 RE-2 to N-1000-II	NC18121-YL NC1861-BL	18 18	12 conductor shielded 6 conductor shielded	75' (23 m) 500' (152 m)		
PR-10, PR-12 Indala readers:	NC1861-BL	18	6 conductor shielded	500' (152 m)		
HG-3 hand geometry reader:	NC1861-BL	18	6 conductor shielded	500' (152 m)		
11 conductor keypad	NC18121-YL	18	12 conductor shielded	500' (152 m)		
5 conductor keypad	NC1861-BL	18	6 conductor shielded	500' (152 m)		
Alarm input points	NC1821-GR or NC 2221-BR	18 22	twisted pair, shielded	2000' (610 m)		
Relay outputs	NC 1821-GR or NC 2221-BR	18 22	twisted pair, shielded 2 conductor	2000' (610 m)		

Note: for Plenum rated cable just add a "P" to Northern's part number prefix

6-8: NCI Cable Part Numbers

<i>Part Number</i>	<i>Description</i>	<i>Application</i>	<i>Length</i>
NC1821-GR	18 AWG/2 conductor	panel/communication cable	1,000'
NC2021-GY-A	24 AWG/2 conductor communication cable 120 ohm impedance, 20 pf/ft capacitance	RS-485 panel/	1,000'
NC1841-GY	18 AWG/4 conductor	reader cable	1,000'
NC1861-BL-500	18 AWG/6 conductor	reader cable	500'
NC1861-BL	18 AWG/6 conductor	reader cable	1,000'
NC18121-YL-500	18 AWG/12 conductor	keypad cable	500'
NC18121-YL	18 AWG/12 conductor	keypad cable	1,000'
NCNET-1	50 ohm	network cable	1,000'
NC2221-BR	22 AWG/2 conductor	alarm cable	1,000'
NC1821-OR	18 AWG/2 conductor	power/door cable	1,000'
NCC59206-BK	RG-59	video cable	1,000'
NCP1821-GR	18 AWG/2 conductor Plenum	panel/communication cable	1,000'
NCP2021-WH-A	24 AWG/2 conductor Plenum 120 ohm impedance, 20 pf/ft capacitance	RS-485 communication cable	1,000'
NCP1841-GY	18 AWG/4 conductor Plenum	reader cable	1,000'
NCP1861-BL-500	18 AWG/6 conductor Plenum	reader cable	500'
NCP1861-BL	18AWG/6 conductor Plenum	reader cable	1,000'
NCP18121-YL	18 AWG/12 conductor Plenum	keypad cable	1,000'
NCP18121-YL-500	18 AWG/12 conductor Plenum	keypad cable	500'
NCPNET-1	50 ohm Plenum	network cable	1,000'
NCP2221-BR	22 AWG/2 conductor Plenum	alarm point cable	1,000'
NCP1821-OR	8 AWG/2 conductor Plenum	power/door cable	1,000'

6-9: Configurations for RS-232 Serial Communication Ports

PC's, DigiBoard or WIN-EXP-8 or 16 connected to a MODEM or a C-100 (C setting)

PC/DigiBoard			WIN-EXP-8 or 16			Modem DCE			C-100 (C)		
DB	25	male	DB	25	male	DB	25	female	DB	25	female
1	Shld	—	1	Shld	—	1	Shld	—	1	n/c	
2	TxD	output	2	TxD	output	2	TxD	input	2	TxD	input
3	RxD	input	3	RxD	input	3	RxD	output	3	RxD	output
4	RTS	output	4	RTS	output	4	RTS	input	4	RTS	n/a
5	CTS	input	5	n/c		5	CTS	output	5	n/c	
6	DSR	input	6	DSR	to 20	6	DSR	output	6	n/c	
7	GND	common	7	GND	common	7	GND	common	7	GND	common
8	DCD	input	8	DCD	input	8	DCD	output	8	n/c	
20	DTR	output	20	DTR	to 6	20	DTR	input	20	n/c	
22	RI	input	22	n/c		22	RI	output	22	n/c	

PC's or WIN-EXP-8 or 16 connected to a 485-PCI-2 or EXP (SW1-1 & SW2-1 closed & SW1-2 and SW2-2 open)

PC			WIN-EXP DTE			485-PCI-2			PC-EXP/CCTV		
DB	9	male	DB	9	male	DB	9	female	DB	9	female
1	DCD	input	1	DCD	input	1	n/c		1	n/c	
2	RxD	input	2	RxD	input	2	RxD	output	2	RxD	output
3	TxD	output	3	TxD	output	3	TxD	input	3	TxD	input
4	DTR	output	4	DTR	to 6	4	DTR	to 6	4	n/c	
5	GND	common	5	GND	common	5	GND	common	5	GND	common
6	DSR	input	6	DSR	to 4	6	DSR	to 4	6	n/c	
7	RTS	output	7	RTS	output	7	RTS	to 8	7	n/c	
8	CTS	input	8	n/c		8	CTS	to 7	8	n/c	
9	RI	input	9	n/c		9	n/c		9	n/c	

C-100 (M setting) or a 485-HUB-2 connected to a MODEM

C-100 (M)			485 HUB			485 MODEM DCE			DB9/25 Adapter		
DB	9	male	DB	9	male	DB	9	female	DB9	25	
1	N/C		1	n/c		1	Shld	—	1	DCD	8
2	TxD	output	2	TxD	output	2	TxD	input	2	RxD	3
3	RxD	input	3	RxD	input	3	RxD	output	3	TxD	2
4	RTS	n/a	4	RTS	to 5	4	RTS	input	4	DTR	20
5	CTS		5	CTS	to 4	5	CTS	output	5	GND	7
6	DSR		6	DSR	to 20	6	DSR	output	6	DSR	6
7	GND	common	7	GND	common	7	GND	common	7	RTS	4
8	n/c		8	n/c		8	DCD	output	8	CTS	5
20	n/c		20	DTR	to 6	20	DTR	input	9	RI	22
22	n/c		22	n/c		22	RI	output			

General rules of thumb:

- Inputs are connected to outputs
- Two outputs are never connected together
- The hardware handshaking lines should be ignored in software (if possible)
- For connecting 2 **DB25** DTEs together cross pins 2 & 3, 4 & 5, 8 & 20, and connect 6 to 20
- For connecting two **DB9** DTEs together cross pins 2 & 3, 1 & 4, 7 & 8, and connect 4 to 6
- Keep cables away from electrical noise sources and less than 50 feet long
- Use shielded cable and connect all of the units to the same earth ground point

Section 7: Locks and Suppression

An S-4 Suppressor Kit must be installed with every electrical switching device run through a relay contact on the N-1000-III/IV. The Suppressor Kit protects the N1000-III/IV from the power generated by the collapsing magnetic field of an electrical load device.

The S-4 Suppressor Kit consists of two identical pieces. Each piece contains a resistor, a capacitor and tranzorb network. These parts are encapsulated in a rubber-like insulating material. One piece is installed across the relay contacts without regard to polarity. The second is installed within 18 inches (457 mm) of the electrical load locking device, without regard to polarity. (See Figure 7-1.)

DO NOT run the panel wires or the lock power wires in the same cable/conduit as the reader/communication line cables. The lock wiring should be at least 12 inches away from the data lines, or it should have a separate conduit.

DO NOT power door locks with the same power supply used for the N-1000-III/IV or card readers.

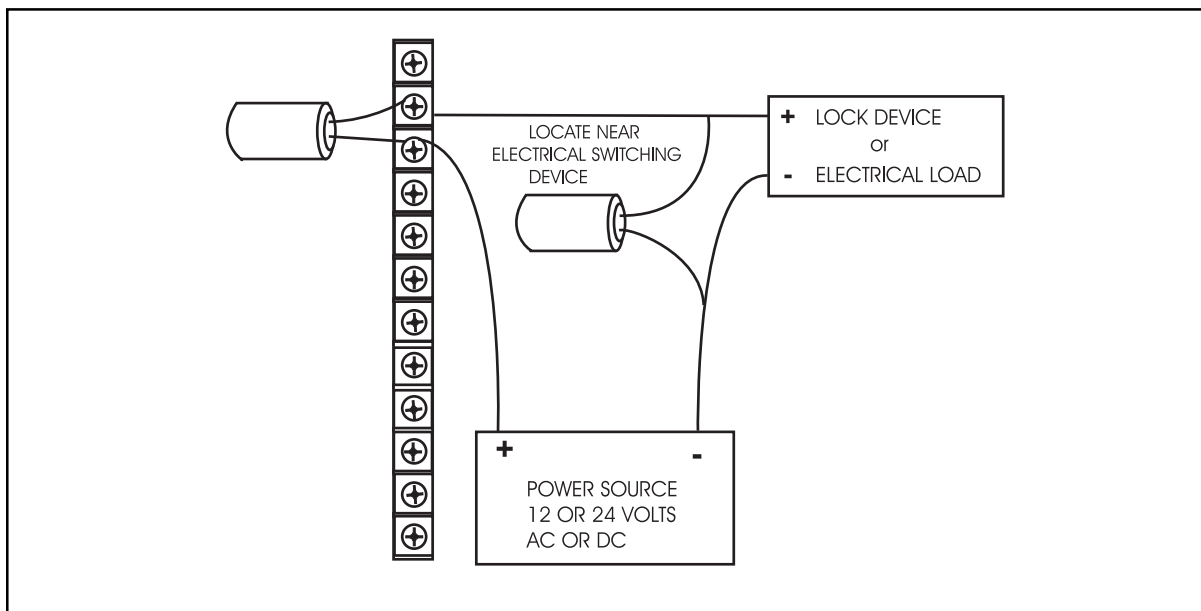

Figure 7-1. **S-4 Suppressor Kit Installation.**

Section 8: Grounding

It is important to ground all N-1000-III/IV control panels properly. Each panel in the communication loop should be individually grounded.

In some locations, the individual earth ground is not adequate and a separate 12-14 gauge Common Ground wire should be run along with the communication loop wire. Ground this wire at one location for the entire system. The 18 gauge or larger cable must be connected from the panel ground point directly to earth ground. The grounding point is shown in Figure 8-1.

Note: The X-4 transformer's earth ground (TB9-1, refer to *Section 4-7*) may be used if an unsuitable earth ground exists. The transformer's 3rd ground prong must be plugged into the outlet.

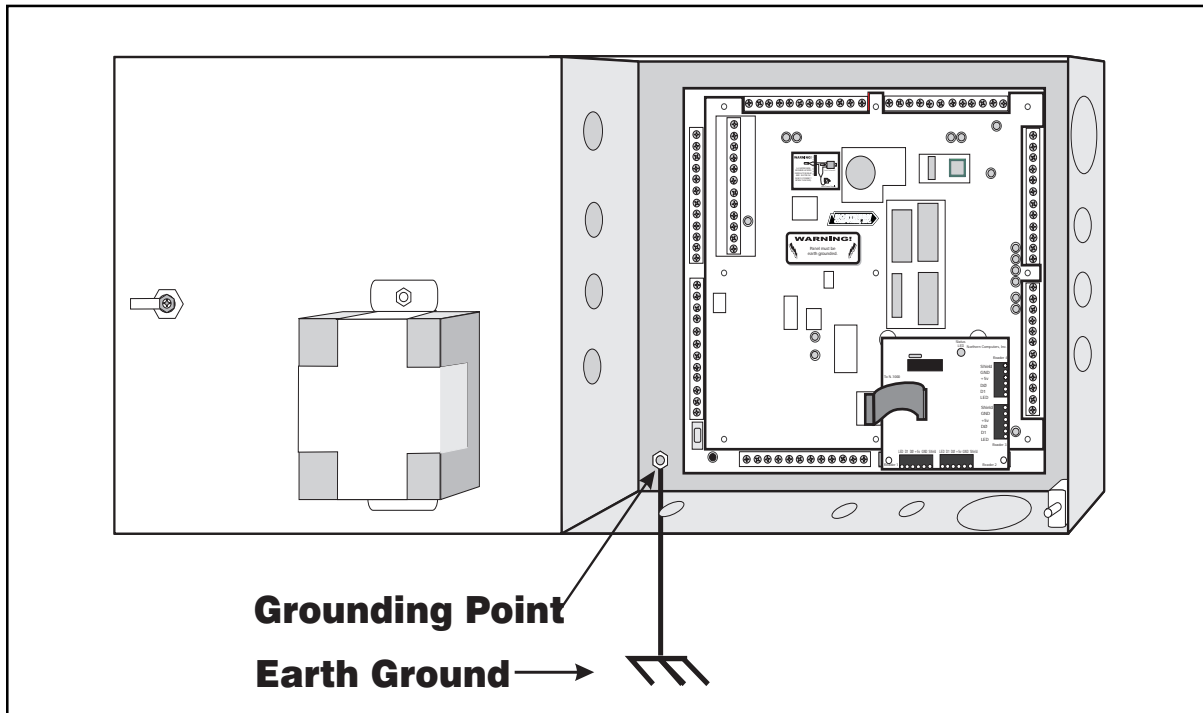

Figure 8-1. **Access Control System with Grounding Point.**

NOTE: The X-4 transformer's earth ground (TB9-1, see *Section 4-7*) may be used if an unsuitable earth ground exists. The 3rd ground prong must be plugged into the outlet.

Use one or the other; **DO NOT USE BOTH** TB9-1 and the "local" chassis ground.

The chassis earth ground is preferred.

Use one or the other, **DO NOT USE BOTH** TB9-1 and the “local” chassis ground. **The chassis earth ground is preferred.**

In installations where there is a significant amount of electrical noise, shields should be grounded outside of the panel.

The access control system should use a consolidated earth ground, in which the power line, telephone and access control system ground rods are bonded together. A consolidated earth ground eliminates the problem of step voltage blowout, in which measurable voltage potential exists between earth ground rods, resulting in a current flow path and damage to the access control system during a lightning strike.

Ground wire runs should be as short and straight as possible. Avoid sharp turns and use a minimum radius of eight inches (203 mm) for bends. Ground wires should be run separate from other wires and be routed toward the earth. Do not run ground wires parallel to metal without proper bonding to the metal. Use of eight foot (2.4 m) copper clad ground rods is recommended. Consolidated earth ground configuration is shown in figure 8-2.

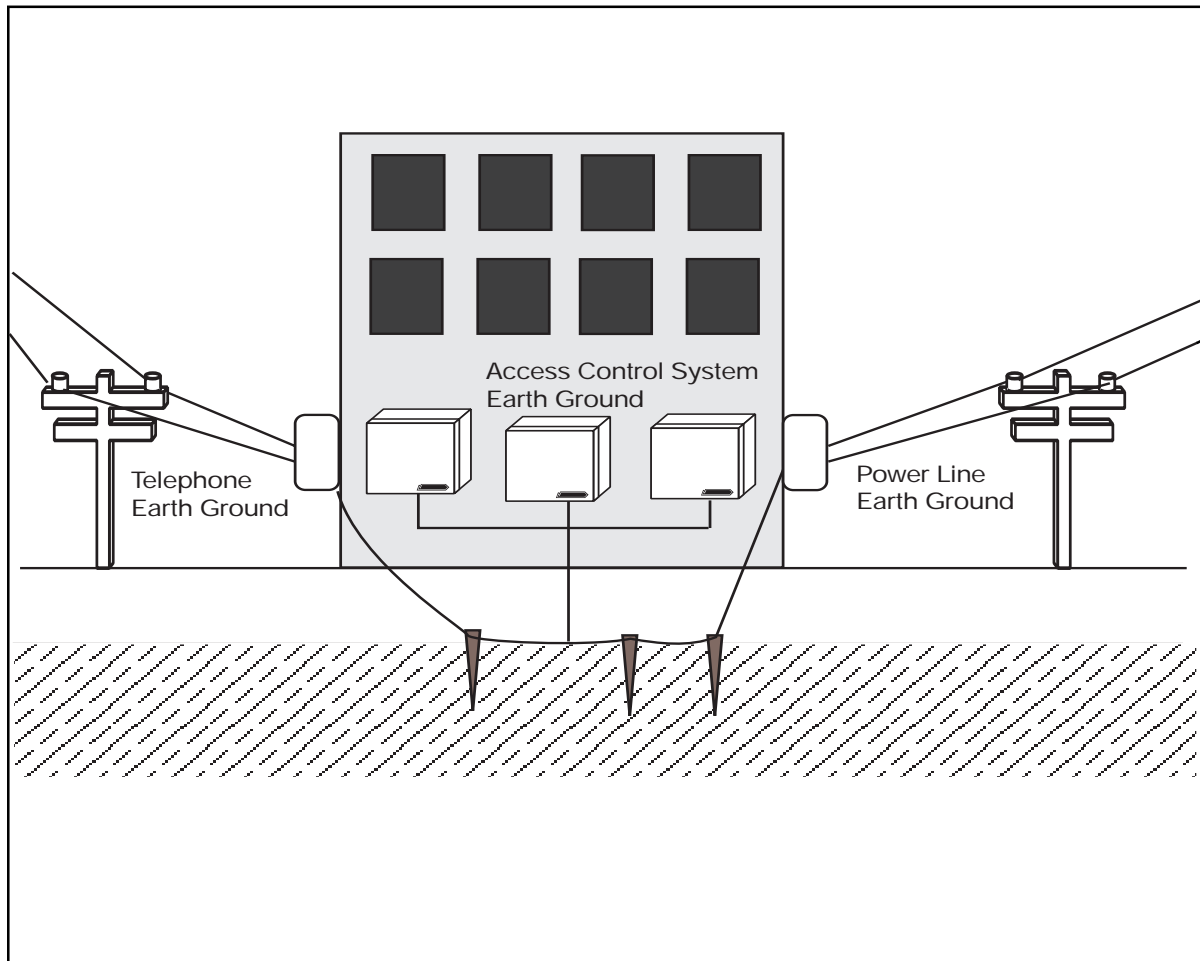

Figure 8-2 **Access Control System with Consolidated Earth Ground.**

Section 9: Power

The N-1000-III/IV requires a 16.5 VAC, 50 VA, 60 HZ or a 12 VDC linear (2 Amp continuous) primary power supply. If using an AC power source as primary power supply, connect the primary power supply to TB9 positions 4 and 5, without regard to polarity. If using a DC power source as primary power, connect the primary power supply to TB9 positions 2 and 3, noting polarity. Use one or the other for primary power supply, not both. N-1000-III/IV AC power terminals are shown in figure 9-1.

Upon loss of primary power, the control panel is powered from the 12 VDC (4 amp/hour) backup battery, if present, for up to four hours of full operation. Alarm point #19 goes into alarm state upon primary power loss. Battery wires with fast-on connectors are soldered to the N-1000-III/IV panel. Use these to connect the 12 VDC battery to the panel, *with regard to polarity* (Figure 9-1).

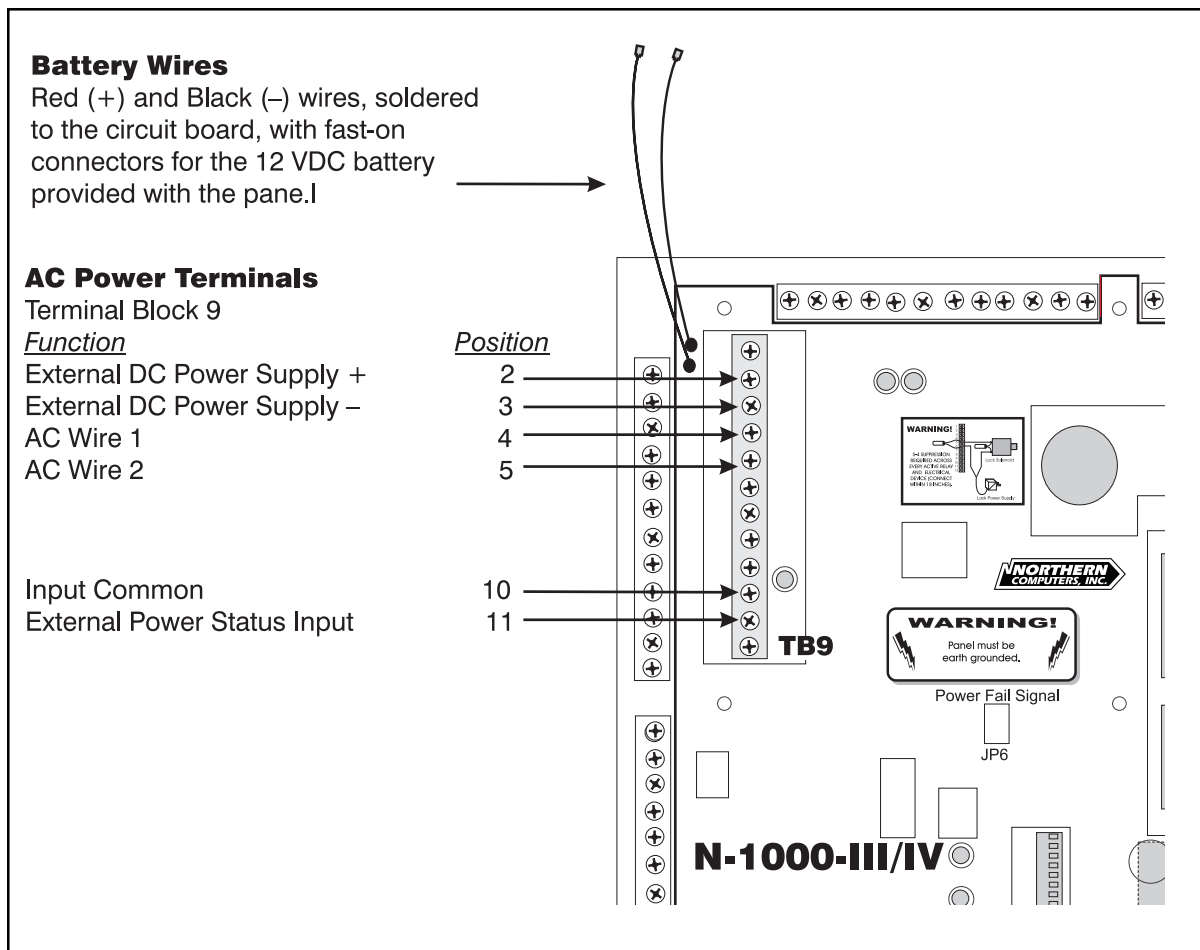

Figure 9-1 AC, Optional External DC and Backup Power Connections.

For backup function with 12 VDC power, select a 12 VDC power supply with battery backup capability and/or use the standard 12 VDC backup battery provided with the control panel. If the external power supply has a relay contact output which indicates a power failure, then it should be wired to TB9-10 and TB9-11. Jumper JP6 (Power Fail Signal) must be moved to Position 1 and 2 in order to enable the external input.

Upon loss of backup battery power, the control panel ceases operation, but retains database/transaction buffer memory for up to 7 days.

Power-up Sequence for the N-1000-III/IV:

- Step 1: Set DIP-switch and verify jumper settings.
- Step 2: Make primary power supply connections.
- Step 3: Make backup battery connections.

Power-down Sequence for the N-1000-III/IV:

- Step 1: Remove backup battery connections.
- Step 2: Remove primary power supply connections.

Appendix A: Programming Quick Reference Guide

Preface

The following Programming Guide applies to the N-1000-II and the N-1000-III/IV panels. The text indicates where there are differences between the N-1000-II and the N-1000-III/IV. These panels can be programmed using Northern's access control software installed on a PC. Information on time zones, areas, panel variables and access levels can be managed automatically using this software.

These operations can also be performed via terminal or printer/programmer. This Programming Guide provides basic code format information necessary to program the N-1000-II and N-1000-III/IV control panels. For complete explanations and examples, contact the factory.

Note: If the N-1000-II or the N-1000-III/IV is to be used in an existing N-1000-II system, the N-1000-II must be at least version 7.0 panel firmware.

Notation Conventions

The following notation conventions are used:

bold	Literal elements of a command that must be entered exactly as shown.
<i>italic</i>	Variables that must be defined by the user. Descriptions of these variables follow this section
_ (underscore)	A space
<CR>	The ENTER key (Carriage Return)
[]	Brackets surround optional command elements.
{ }	Braces surround two or more choices
	A vertical bar separates individual choices within the braces: {choice 1 choice 2 choice 3}. The user must select only one of the choices.

Invalid Code Error Messages

Error Message	Violation
AP	Anti-passback violation.
EX	Code expired (Limited Use or Visitor status)
NF	Code not found (programmed) in memory for the selected card reader or keypad.
TR	Trace message (enabled with the C Sub-command 1/T option). Access is allowed.

TZ	Time Zone violation.
PN	PIN number violation.
SC	Site Code violation.

User Defined Parameter Variables

<i>Parameter</i>	<i>User Response</i>														
<i>code</i>	card number or keycode (1-65535)* OR card number or keycode range. In a card number or keycode range, specify the first and last codes in the range, separated by a hyphen (-).														
<i>code1</i>	first code in a range (1-65535)*														
<i>code2</i>	last code in a range (1-65535)*														
<i>cc</i>	the number of characters to use in the access code number (F Command, Sub-Command 5)														
<i>dev</i>	device number, as shown below: <table> <thead> <tr> <th>(N-1000-II)</th> <th>(N-1000-III/IV)</th> </tr> </thead> <tbody> <tr> <td>1= card reader 1</td> <td>1= card reader 1</td> </tr> <tr> <td>2= card reader 2</td> <td>2= card reader 2</td> </tr> <tr> <td>3= keypad 1</td> <td>3= card reader 3</td> </tr> <tr> <td>4= keypad 2</td> <td>4= card reader 4</td> </tr> <tr> <td></td> <td>5= keypad 1</td> </tr> <tr> <td></td> <td>6= keypad 2</td> </tr> </tbody> </table>	(N-1000-II)	(N-1000-III/IV)	1= card reader 1	1= card reader 1	2= card reader 2	2= card reader 2	3= keypad 1	3= card reader 3	4= keypad 2	4= card reader 4		5= keypad 1		6= keypad 2
(N-1000-II)	(N-1000-III/IV)														
1= card reader 1	1= card reader 1														
2= card reader 2	2= card reader 2														
3= keypad 1	3= card reader 3														
4= keypad 2	4= card reader 4														
	5= keypad 1														
	6= keypad 2														
<i>day(s)</i>	day of week, as shown below: <ul style="list-style-type: none"> 1= Monday 2= Tuesday 3= Wednesday 4= Thursday 5= Friday 6= Saturday 7= Sunday 0= Holiday notation (all holidays) 														
<i>dd</i>	day of month (1-31)														
<i>deb</i>	debounce time (1-255) in seconds														
<i>desc</i>	descriptive name up to 12 characters														

* Value range

With the OL Option it is a 10 digit number where the value range of the 1st 5 digits is 1-65535; and the 2nd 5 digits is 1-65535

With the OJ Option it is an 11 digit number where the value range of the 1st 4 digits is 1-4095; and the next 7 digits is 1-1,048,575

With the Y Option it is a 16 digit number with a range of 1- 9,999,999,999,999,999

Parameter	User Response																		
<i>durA</i>	duration of time as shown below: {S_sec M_min H_hr} where <i>sec</i> = seconds (1-63) <i>min</i> = minutes (1-63) <i>hr</i> = hours (1-63)																		
<i>dr1</i>	relay that is pulsed when a duress status is received from Reader 1																		
<i>dr2</i>	relay that is pulsed when a duress status is received from Reader 2																		
<i>errors</i>	error count (0-255)																		
<i>fsn</i>	format slot number (1-8)																		
<i>format</i>	format command parameters for a specific card reader and/or cards (see F command)																		
<i>group</i>	group number (1-32)																		
<i>h1</i>	start time zone: hours (00-23)																		
<i>h2</i>	end time zone: hours (00-23)																		
<i>hol</i>	holiday number (1-32)																		
<i>input</i>	input number (1-16) are hardwire Panel/System alarms <table border="0"> <tr> <td>(N-1000-II)</td> <td>(N-1000-III/IV)</td> </tr> <tr> <td>17 com status 20 mA</td> <td>17 com status 485-20 mA</td> </tr> <tr> <td>18 aux status 232 port</td> <td>18 aux status 232 port</td> </tr> <tr> <td></td> <td>19 primary power</td> </tr> <tr> <td></td> <td>20 tamper</td> </tr> <tr> <td></td> <td>21 input ground fault status</td> </tr> <tr> <td></td> <td>22 low power supply</td> </tr> <tr> <td></td> <td>23 external 5 volt short</td> </tr> <tr> <td></td> <td>99 reset</td> </tr> </table>	(N-1000-II)	(N-1000-III/IV)	17 com status 20 mA	17 com status 485-20 mA	18 aux status 232 port	18 aux status 232 port		19 primary power		20 tamper		21 input ground fault status		22 low power supply		23 external 5 volt short		99 reset
(N-1000-II)	(N-1000-III/IV)																		
17 com status 20 mA	17 com status 485-20 mA																		
18 aux status 232 port	18 aux status 232 port																		
	19 primary power																		
	20 tamper																		
	21 input ground fault status																		
	22 low power supply																		
	23 external 5 volt short																		
	99 reset																		
<i>i/o</i>	This symbol actually stands for { I_#,O_#,G_# } and indicates that you must choose one Input , Output , or Group . Refer to individual parameter for details.																		
<i>limit</i>	maximum use limit																		
<i>m1</i>	start time zone: minutes (00-59)																		
<i>m2</i>	end time zone: minutes (00-59)																		
<i>mm</i>	month number (1-12)																		
<i>nh</i>	card numb mode time (1-65535 units) where each unit equals 15 seconds. And where once a valid card is read, it will not read on any other reader connected to this panel. Card numb duration is cleared at midnight (00:00)																		
<i>nn</i>	a two digit number between 16 and 64 that indicates the number of characters to skip after the beginning of the access code number																		

Parameter	User Response
<i>output</i>	<p>output number</p> <p>(N-1000-II)</p> <p>N-1000 (1-4, 13, 14)</p> <p>N-1000-X (1-8, 13, 14)</p> <p>1st AEP-3 (17-24) 13 = rdr 1 LED</p> <p>2nd AEP-3 (25-32) 14 = rdr 2 LED</p> <p>(N-1000-III/IV)</p> <p>N-1000 (1-4, 11, 12, 13, 14) 11 = rdr 1 LED</p> <p>N-1000-X (1-8, 11, 12, 13, 14) 12 = rdr 2 LED</p> <p>1st AEP-3 (17-24) 13 = rdr 3 LED</p> <p>2nd AEP-3 (25-32) 14 = rdr 4 LED</p>
<i>pn</i>	panel number (0-63); Ø= global command
<i>relock</i>	<p>component to relock as shown below:</p> <p>{I_input O_output G_group} See <i>input</i>, <i>output</i>, and <i>group</i>.</p>
<i>shunt time</i>	<p>shunt time as shown below:</p> <p>{S_sec M_min H_hr} where</p> <p><i>sec</i>= seconds (1-63)</p> <p><i>min</i>= minutes (1-63)</p> <p><i>hr</i>= hours (1-63)</p>
<i>sss</i>	card site code(s) (0-65535)
<i>tz</i>	time zone number (0-63)
<i>tz link</i>	time zone link number
<i># delay count</i>	1-255 (255 = 6 seconds delay)
<i>zgn</i>	input group number 1-16

Error Codes

C?	Command Structure Error
F?	Database Full Error
R?	Range Error
S?	Syntax Error
T?	Timeout Error
U?	Unable to Complete Error

Programming Order

The following command list serves as a general guideline for the chronological order of programming.

<i>Command</i>	<i>General Purpose</i>
I	Clear panel memory
I	Initialize panel
T	Set time
D	Set date
F	Set format commands
N	Assign descriptive names
L	Define time zones
H	Set holidays
G	Define groups
P	Set interlocks
V	Assign input/output/group information
O	Assign input/output/group information
C	Add codes (cards/keycodes)
M	Set buffer/print options
E	Eliminates pin/invalid attempt counting
A	Assigns reader to pulse output/input/groups
W	Defines alarm input type (NO, NC, & supervision)
Z	Creates groups of Inputs (zones)

Commands

The following commands are listed in alphabetical order

A Command

Sub-Command 1

Function: Assign reading devices (card readers/keypads) to activate specified input points, output points and groups.

Syntax: ***_A=****pn_dev_i/o_ <CR>*

Example: ***_A= 1_2_I_5***

A valid code use at Card Reader 2 (Device 2) on Panel 1 shunts Input 5 for the duration of the input's set shunt time.

Sub-Command 2

Function: Set the device from which a PIN is expected for a given card reader. Eliminates required PIN use at specified card reader.

Syntax: `_A=pn_dev_D_Ø_dev< CR>` (first dev = card reader,
second dev = keypad)

Example: `_A= 1_2_D_Ø`

A PIN is not required for access at Card Reader 2 (Device 2) on Panel 1. (This is the most common use of this command.)

C Command

Sub-Command 1

Function: Add a single or multiple codes to memory with special options.

Syntax: `_C=pn_code_tz_dev [_i/o][_A][_K][_L_#][_P_#][_T][_N_desc]< CR>`

User

options: A: Set Anti-passback feature to "IN" (card added with "IN" status.)
(NOTE: the default status of cards is "Unused")

K: No PIN required

L_#: Limited code use

P: Personal Identification Number (PIN)

T: Trace code

N: Name (must not be used with access control software)

Example: `_C= 1_594_1_1_2_A_P_12345`

Card number 594 is valid with PIN 12345 during Time Zone 1 at both card reader/keypad 1 and card reader/keypad 2 (devices 1 and 2) on panel 1.

Sub-Command 2

Function: Allow cards to have different time zones per reader or keypad on a single panel. Panel must be initialized with I Command, Z_Ø option.

Syntax:

N-1000-II `_C=pn_card#_tz1_tz2_{dev1/dev3}_{dev2/dev4}< CR>`

or

N-1000-III/IV `_C=pn_card#_tz1_tz2_tz3_tz4_{dev1/dev5}_{dev2/dev6}_{dev3}_{dev4}< CR>`

Example: `_C= 1_750_1_3_1_2`

Card number 750 is valid at panel during Time Zone 1 on Reader 1 and Time Zone 3 on Reader 2.

Sub-Command 3

Function: Deletes single or multiple code(s) from memory.

Syntax: `_C=pn_code< CR>` or `_C=pn_code1-code2_Ø< CR>`

Example: `_C=1_25Ø-299_Ø`

Codes 250-299 are deleted from memory in panel 1.

Sub-Command 4

Function: Generate code database reports based on user-selected parameters.

Syntax: `_C=pn_{L_limit | N | R | U | Z_tz} [_code]< CR>`

User

options:

L: Limited Use/Visitor status specification

N: IN status

R: Full report

U: OUT status

Z: time zone specification

Example: `_C=1_L_3_1ØØØ-12ØØ`

The returned report includes only those codes from 1000 to 1200 with three or fewer uses remaining in Panel 1.

Sub-Command 5

Function: Manually set anti-passback IN/OUT code status.

Syntax: `_C=pn_{I | O}_card #< CR>`

User

options:

I: Set IN status

O: Set OUT status

Example: Reset code

Cardholder 750 enters the building in the morning via the *In* reader (on Panel 1, Device 1) and exits without using the *Out* reader (Panel 1, Device 2) in the evening. The following morning, the cardholder is denied access at the *In* reader (anti-passback violation).

The system operator enters the following command to set the status of Card 750 to OUT: `_C=1_O_75Ø`

Card 750 is then allowed entry at the *In* reader.

Sub-Command 6

Function: Allow information in a split time zone card record to be modified without overwriting the whole command.

Syntax: `_C=pn_T_card#_tz_tz_dev <CR> *`

`_C=pn_C_card#_DeviceList<CR>`

User

Options: T: Reset time zones

C: Delete devices from the card without removing it from the panel

Example: `_C=1_T_750_3_5_1`

Card 750 already exists in panel but is valid during Time Zones 1 & 6. Now it changes Card 750 to be valid during Time Zone 3 and 5 at device 1.

Example: `_C=1_C_22939_3_4`

Card 22939 had access to devices 1 through 4 at panel 1. Card 22939 now only has access at devices 1 and 2 at Panel 1.

If Ø is entered for the 1st or 2nd Time Zone (or both) it will **not overwrite the existing Time Zone. If a device is listed it will be **added** to the existing device list.*

Sub-Command 7

Function: Immediately set the status of all cards to “Out.” Used with panels programmed for Anti-passback.

Syntax: `_C=pn_F<CR>`

Example: `_C=1_F<CR>`

All cards in Panel 1 are set to “Out” status.

D Command

Function: Set control panel date.

Syntax: `_D=pn_mm/dd_day <CR>`

Example: `_D=Ø_2/6_3`

The date is set for Wednesday, February 6 in all panels.

Leap Year

Syntax: `_D=pn_2/29_Day of week 1-7`

Syntax: `_D=pn_mm/dd_dow_[yyyy]<CR>`

Note: The date command has the option of adding a four digit year after the day of the week. If no year is specified, the panel will assume it is not a leap year, and February 29th will be skipped.

E Command

Sub-Command 1

Function: Establish the time zones for required use of PINs at specified panels.
(Note: Panel must also be initialized with the P option.)

Syntax: `_E=pn_P_tz <CR>`

Example: `_E=1_P_2`

During Time Zone 2, a valid card/PIN combination is required for access in Panel 1. Outside of Time Zone 2, only a valid card is required for access.

Sub-Command 2

Function: Pulse input point, output point or group, based on a selected number of consecutive invalid code uses.

Syntax: `_E=pn_C_errors_[R_{device #}]{I_input | O_output | G_group}`
`<CR>`

Example: `_E=1_C_3_R_3_O_3<CR>`

Upon three consecutive invalid code uses at Device 3, on Panel 1, Output 3 is pulsed.

F Command

Sub-Command 1

Function: Sets the method of interpreting card read data for Wiegand type cards.

Syntax: `_F=pn_fsn_format< CR>`

User

options:

<i>CR-1 Wiegand Card Swipe Reader:</i>	<code>_F=pn_1_26_S_1_D_1_B1_B2_B3_B4</code>
<i>CI-1 Wiegand Card Insert Reader:</i>	<code>_F=pn_1_26_I_S_1_D_1_B1_B2_B3_B4</code>
<i>NR-1 Magstripe Swipe Reader:</i>	<code>_F=pn_fsn_32_S_Ø_D_Ø_B1_B2_B3_B4</code>
<i>PR-1-280 Cotag Proximity Reader:</i>	<code>_F=pn_fsn_32_S_Ø_D_Ø_B1_B2_B3_B4</code>
<i>PR-2 Hughes/IDI Proximity Reader:</i>	<code>_F=pn_fsn_34_S_1_D_1_B1_B2_B3_B4</code>
<i>HG-1 Hand Geometry Reader:</i>	<code>_F=pn_fsn_32_S_Ø_D_Ø_B1_B2_B3_B4</code>
<i>5-Conductor Keypad:</i>	<code>_F=pn_fsn_32_S_Ø_D_Ø_B1_B2_B3_B4</code>
<i>Dorado Magstripe Cards:</i>	<code>_F=pn_fsn_34_S_1_D_Ø_B1_B2_B3_B4</code>
<i>Sielox Wiegand Cards:</i>	<code>_F=pn_fsn_34_S_1_D_1_B1_B2_B3_B4</code>
<i>Sielox Proximity Cards:</i>	<code>_F=pn_fsn_32_S_Ø_D_Ø_B1_B2_B3_B4</code>
<i>NCS 25-Bit Cards:</i>	<code>_F=pn_fsn_25_S_1_D_1_B1_B4_B2_B3</code>
<i>NCS 29-Bit Cards:</i>	<code>_F=pn_fsn_29_S_1_D_1_B1_B4_B2_B3</code>
<i>Kidde Cards:</i>	<code>_F=pn_fsn_31_S_1_BØ_B2_B3_B4</code>
<i>Continental 36-Bit Cards:</i>	<code>_F=pn_fsn_36_S_3_D_2_B1_B2_B3_B4</code>
<i>Continental 37-Bit Cards:</i>	<code>_F=pn_fsn_37_S_3_D_2_B1_B2_B3_B4</code>

Example: `_F=1_2_32_S_O_D_Ø_B1_B2_B3_B4`

The format command entered (as format #2) enables use of Cotag Proximity Readers in Panel 1.

Sub-Command 2

Function: Sets the format for use with ABA encoded cards—12 digits are used with PC-PAK and WIN-PAK.

Syntax: **_F=pn_M[_R]_positions 1-12< CR>**

User

option **R:** Allows debugging of raw card number information.

Example: **_F= 1_M_0_0_0_0_0_0_1_2_3_4_5_6< CR>**

The number indicates the digit number from the card. The position of the number in the format indicates where the digit will appear in the final mapped card number. A zero in the format will cause a zero to appear at that point in the final card read.

Note: User Option R can be used as shown here when adding to existing information or with position specified as a separate command.

Sub-Command 3

Function: Set the format for 35 bit cards used with the I Command, OJ Option.

Syntax: **_F=pn4_35_S_1_D_2_B1_B2_B3_B4< CR>**

Sub-Command 4

Function: Set the format for use with 29 bit format cards (TI/Silicon Systems) with the I Command, OL Option.

Syntax: **_F=pn_fsn_29_S_1_1_B0_B4_B2_B3< CR>**

Sub-Command 5

Function: Sets the format to support Track 1 Readers, for use with the M400-NORT1 reader.

T: Track 1 reader.

Syntax: **_F=pn_M_T_nn_cc< CR>**

G Command

Function: Define output point groups.

Syntax: `_G=pn[_Z_input]_group_outputs[_W_wgroup]< CR>`

Example: `_G=1_1_5_6_7_8`

Group 1 is defined as outputs 5, 6, 7 and 8 in Panel 1.

User

options: W: Warning group

Z: Special output groups

Note: All warning groups must be on the N-1000 panel NOT the AEP-3 board.

Syntax: `_G=pn_group_W_wgroup__Outputs< CR>`

Example: `_G=1_1_W_2_1_1_2< CR>`

Creates Group 1 on Panel 1. Group 1 has relays 1 and 2 and uses Group 2 as a warning group. (Group 2 must be created and given a pulse time.)

Syntax: `_G=pn_Z_input_group_outputs< CR>`

(When the group is used singly the input number functions only to signify that the group is Special and will follow the rules below. In the case where only one group is used this should be Ø in order to prevent action being transferred to the next group);

The single Special Group has one main function: It will not go on during its time zone unless a card is swiped to turn it on. But it will go off automatically at the end of its time zone in the normal manner. This means, for example, if your front door is on a time zone and there is a snow storm preventing personnel from getting to the office, the door will not unlock.

Example: `_G=pn_Z_Ø_2_3_4< CR>`

Group 2 containing relays 3 and 4 is established. A time zone can then be attached to Group 2 via the V Command. When the time zone begins, nothing happens. When a card valid for Group 2 is used, relays 3 and 4 go on. Subsequent reads during the time zone toggle relays 3 and 4 off or on. If they are on when the time zone ends, they go off.

H Command

Function: Set holiday dates.

Syntax: `_H=pn_hol_mm/dd< CR>`

Deleting Holidays:

To delete an existing holiday database entry, enter the H Command for the desired holiday number WITHOUT the month (*mm*) and day (*dd*) parameters.

Example: `_H=Ø_1_12/25`

Holiday 1 is set as December 25 in all panels.

I Command

Function: Initialize the control panel, enabling features and programming options for future use and set panel site code(s).

Syntax: `_I=pn[_sss][_A][_B][_E][_F][_G][_H_nh][_K][_I][_L][_M][_N][_OA]{_OD_dr1|_dr2}[_OJ][_OL][_ON][{_OP_19_S[_OP_Ø]}][_P][_R][_S][_U][_V][_Y][_Z_Ø] [_Z_tzn]< CR>`

User

options:

- A: Anti-passback
- B: Continuous code reads (busy)
- E: Free egress
- F: Forgiveness (with anti-passback)
- G: Groups
- H: Numb mode "nh" is unit of 15 seconds
- K: Keypads
- I: In/Out command sent from panel
- L: Limited Use Cards
- M: Card Reader LED function reversed
- N: Names
- OA: Alarms are reported when coming out of time zone shunt
- OD: Duress option (N-1000-II only) requires card/keypad configuration. PIN numbers entered where the last digit is off by 1 (+/-) will cause "dr1" duress relay for Reader 1 or "dr2" duress relay for Reader 2 to pulse (can be same duress relay). For example, if the normal PIN number is 12345, entering number 12346 or 12344 will create a duress condition.
- OJ: Format for 35 bit card numbers, the first 12 bits (after the starter bits) are interpreted as the site code and the next 20 as

the card number, followed by 1 stop bit. The resulting site code and card number are concatenated to form one card number, which is sent to the head end software as a 12-digit number.

NOTE: A special format is required. Refer to *F Command, Sub-Command 3*.

Application Note: For simplicity of system management, it is recommended that you set the site code value to \emptyset when the OJ Option is used.

- OL: Create Wiegand card numbers by concatenating site code with card number. The result is transmitted as a 12 digit number.
- ON: Normals are reported when coming out of time zone shunt
- OP: Switches the Power Fail Input from Input Point 8 to Input Point 19 (**_OP_19_S**) or from Input Point 19 to Input Point 8 (**_OP_Ø**). NOTE: Redirecting the Power Fail to Input 19 reclaims Input 8 as a normal input on the AEP-5 board only. However, this change will disable the AEP-5 Board Present/Functioning alarm.
- P: Personal identification numbers (PIN)
- R: Restart
- S: Supervisory Board (Not for use with N-1000-III/IV)
- U: The number of cards panel should set itself for
- V: Visitor cards
- Y: Long format ABA cards
- Z_Ø: Split time zone
- Z_tzn: All cards with time zone numbers higher than the number indicated will use the next higher time zone at Reader 2. At Reader 1 they will use the time zone attached to the card number.

Global Specification

Control panels MUST be initialized on an individual basis. The global specification ($pn = \emptyset$) is NOT allowed with the I command.

L Command

Function: Define time zones.

Syntax: **_L=** $pn_tz_h1:m1-h2:m2_days$ [*tz link*]**< CR>**

Comment: Time zone definition consists of a reference number, start time, end time, day(s) of week specification and optional link number. The end period of a time zone goes until the last second of the last minute (e.g., 8:00-17:00—at 17:01 the door is locked).

A time zone definition alone causes no action. Time zones must be assigned to cards/keycodes, input points or output points to cause action.

Example: `_L=Ø_1_ØØ:ØØ-23:59_1_2_3_4_5_6_7_Ø`

Desired time zone: 24 hours every day, including holidays.

M Command

Sub-Command 1

Function: Sets control panel buffer/print options.

Syntax: `_M=pn[_P][_D][_L][_V][_X][_F][_R]< CR>`

User

- options:*
- P: The panel buffers all activity.
 - D: The panel does not buffer or print valid code activity
 - L: The panel buffers and prints all activity
 - V: The panel buffers only valid code activity and prints invalid codes and alarm input point activity.
 - X: The panel buffers all activity and prints invalid codes and alarm input point activity
 - F: The panel “dumps” the buffer when it is within 100 transactions of capacity
 - R: The buffer is dumped, all buffer/transmit options are cleared

Example: `_M= 1_P`

Panel 1 buffers all activity and transmits no activity.

Sub-Command 2

Function: Set control panel anti-passback and “print names” mode of operation.

Syntax: `_M=pn_{A | N | B | E | K | G}< CR>`

User

- options:*
- A: Enable anti-passback
 - N: Disable anti-passback
 - B: Disable names
 - E: Print names

Example: `_M= 1_N`

Panel 1 is operating in the anti-passback mode.

Result: Panel 1 is taken out of the anti-passback mode.

Sub-Command 3

Function: Disables global “OK” message.

Syntax: `_M=Ø_K <CR>`

Sub-Command #4

Function: Time delay between transmissions.

Syntax: `_M=pn_# delay count<CR>`

Default: delay count = 1

Maximum = 255 at 6 seconds between transactions.

N Command

Sub-Command 1

Function: Assigns 12 character descriptive names to codes (cards and keycodes).

Syntax: `_N=pn_C_code_desc <CR>`

Example: `_N=1_C_8562_JONES,_MIKE`

Code 8562 is assigned the name JONES, MIKE in Panel 1.

Sub-Command 2

Function: Assigns 12 character descriptive names to control panels, card readers and keypads.

Syntax: `_N=pn_R_dev_desc <CR>`

Example: `_N=1_R_Ø_LOBBY_PANEL`

Control Panel 1 is assigned the name “LOBBY PANEL”

Example: `_N=1_R_6_BACK_KEYPAD`

Keypad 2 (N-1000-IV) is assigned the name “BACK KEYPAD”

Sub-Command 3

Function: Assigns 12 character descriptive names to input points, output points and groups.

Syntax: `_N=pn_i/o_desc <CR>`

Example: `_N=1_I_6_BACK DOOR CT`

Assigns the name BACK DOOR CT to Input 6 on Panel 1.

O Command

Sub-Command 1

Function: Provides manual control and sets special options for input points, output points and groups.

Syntax: `_O=pn_i/o_{A | C | D | E | I | P | O | T | Z } <CR>`

User

options: A: Acknowledge alarm

C: Clear all options

D: De-energize/Unshunt

E: Energize/Shunt

I: Interlock disable

P: Pulse/Shunt (Definable Duration)

O: Keep on

T: Returns a point to its time zone when removed by the *O command* with the *D or E option*.

Z: time zone control disable

Example: Group 3 (outputs 1, 3, 5, 7) in Panel 60 is de-energized and assigned a 12 second pulse time.

Command: `_O=60_G_3_P`

Result: Group 3 (outputs 1, 3, 5, 7) pulses for 12 seconds.

Sub-Command 2

Function: Used to control input point groups (Zones) which are created using the Z Command.

Syntax: `_O=pn_Z_zgn_E<CR>`

or

`_O=pn_Z_zgn_D<D>`

P Command

Function: Sets interlocks between alarm input points and/or output points.

Syntax: `_P=pn_i/o1_i/o2_{D|E|F|I|N|P|S}_{D|E|F|I|N|P|S}<CR>`

User

options: D: De-energize
E: Energize
F: Follow
I: Invert follow
N: No action
P: Pulse
S: Pulse off

Example: i/o1: Input 5 (motion detector)

i/o2: Output 3 (siren)

Action 1: Energize

Action 2: De-energize

Interlock

command: `_P=1_I_5_O_3_E_D`

Result: When Input 5 goes into alarm state (motion detector triggered), Output 3 energizes (sounding the alarm). When Input 5 returns to normal state, Output 3 de-energizes (turning off the siren).

R Command

Function: Generates control panel database reports which are displayed on the system monitor and/or printer.

Syntax: `_R=pn_{C | G | H | I | O | o | P | p | T | V | Z} <CR>`

Report

options: C: Code (card/keycode) database
G: Groups
H: Holiday schedule
I: Initialization parameters
O: Output points
o: Short output points report
P: Input points
p: Short input points report
T: time zones
V: Firmware version
Z: Z Groups

T Command

Function: Sets control panel time.

Syntax: **_T=***pn_hh:mm* <CR>

Example: **_T=Ø_17:45**

The time is set to 5:45 PM. in all panels.

V Command

Sub-Command 1

Function: Assigns shunt times and time zones to input points **WITH** special options.

Syntax: **_V=***pn_I_input_shunt time_tz[_1][_A_durA[_tzA]][_B[_tzB]][_C][_D_deb][_K_relock][_S[_tzS]][_X][_N_name][_Y[_tzY]]*<CR>

User

options: 1: Disable alarm/normal messages, but transmit trouble messages

A: Acknowledge required

B: Buffered mode activation

C: Clear options

D: Debounce

K: Enable auto-relock

S: Disable alarm/normal messages

X: Reverse alarm/normal states

N: Name input point

Y: Disabling response to interlock by time zone

Example: *Alarm Acknowledge* message without time zone

Input 5 (motion detector) monitors a secure area. You want the input to be shunted (de-activated) during Time zone 20 for free access. Input shunt time is not applicable. You want *alarm acknowledge* message activation.

Command: **_V=1_I_5_Ø_20_A_1Ø**

Result: Input 5 is shunted during Time Zone 20 and is assigned a shunt time of 0 (not applicable). When Input 5 goes into alarm condition, an *alarm acknowledge* message is sent to the system monitor and/or printer. The message is transmitted every 10 seconds until acknowledged with the following command: **_O=1_I_5_A**

Sub-Command 2

Function: Assign pulse times and time zones to output points **WITH** special options.

Syntax: `_V=pn_{O}output_pulse_time_tz[_C][_L][_Y_tzY][_N_name]<CR>`

User

options: C: Clear options

L: Latch

N: Name output point

Y: Disabling response to interlock by time zone

Example: `_V=1_O_4_8_Ø_N_FRONT_SIREN`

Output Point 4 is not time zone controlled and is assigned a pulse time of eight seconds. The output is assigned the name "FRONT SIREN."

Sub-Command 3

Function: Assign pulse times and time zones to groups **WITH** special options.

Syntax: `_V=pn_G_group_pulse_time_tz[_Y_tzY]_N_name <CR>`

User options:

N: Name group

Y: Time zone control interlock

Example: `_V=1_G_5_6_Ø_N_ALL_RELAYS`

Group 5 is not time zone controlled and is assigned a pulse time of six seconds. The group is assigned the name "ALL RELAYS."

W Command (Used with the N-1000-III/IV only)

Function: Program each input point for either NO/NC and Supervised or NON-Supervised operation.

Syntax: `_W=pn_input_{SO|SC|NO|NC}<CR>`

SO: Supervised normally open (Resistor in parallel with switch);

SC: Supervised normally closed (Resistor in series with switch);

NO: Non-supervised normally open; and

NC: Non-supervised normally closed (default).

If an EOL resistor is put on a point, and it is not set up as a supervised point (using one of the commands above), it will report TROUBLE whenever the resistance is connected. This should serve as a warning that the point has not been set up.

Example: `_W=1_9_SO<CR>`

Alarm Input 9 has been programmed as supervised, normally open on Panel 1.

Z Command

Function: Creates groups of inputs (Zones). Allows shunting of multiple inputs. One command can shunt all required points on the panel rather than one command for each point. Commands are similar to the G command.

Creation: **Z**=pn_zgn_input_input etc.

zgn: The number of the group being created (up to 16 of these groups can be created)

input: The input number included in the group.

Control: Through O commands with energize and de-energize such as:

O=pn**Z**_zgn_**E**< CR>

or

O=pn**Z**_zgn_**D**< D>

OR'ing of Inputs

If two or more inputs are interlocked to a single output to energize on alarm and de-energize on normal, both/all inputs must be normal before the interlock will allow the relay to de-energize.

1. This E (Energize) action will allow situations where, for example, several input points can be interlocked to one relay which is driving a sounder, visual alert or digital dialer. When several inputs go into alarm and remain in alarm all at once, the relay will not be turned off *after one of them goes back to normal*. Rather all inputs must go back to normal before the output will be turned off.
2. The above operation is standard. An alternate method, where one input returning to normal would de-energize the relay, is offered as an option through the use of a terminal or text command. The command is written with a G designation in place of the E for energize.

Example: **_P**=pn_**I**_input_**O**_on_**G**_D< CR>

Output Groups by Readers

This feature allows a card to be used to activate one group when it is used at Reader 1 and a different group if it is used at Reader 2.

1. Initialization must include the E Option and the G designation with a number following it. The number following the G will tell the panel that groups with a number higher than this number are to be used in the split method. If the number is EVEN, the jump described below will be 1. If the number is ODD, the jump will be 2. The ODD/EVEN distinction is used to distinguish the situation of regular groups, described here, from that of Paired Special Groups.
2. In setting up the groups and assigning them with access levels, it is necessary to keep in mind that group numbers higher than the number specified in the I command will be incremented by 1 when the card is used at Reader 2. (If the number above was EVEN. If the number above was ODD it will be incremented by 2.) The original group number will be used at Reader 1.

Example: `_I=pn_E_G_4< CR>`

`_C=pn_444_1_1_2_G_3< CR>`

`_C=pn_555_1_1_2_G_7< CR>`

Card 444 will pulse group 3 on either reader but card 555 will pulse Group 7 on Reader 1 and Group 8 on Reader 2.

Appendix B: N-1000-III/IV Compared to N-1000-II

Miscellaneous and Special Items

- Four layer PWB and other improvements provide greater electrical noise immunity.
- High efficiency switching regulators result in reduced heat generation and extended backup battery operation.
- The Four Reader Board on the N-1000-IV allows the panel to support a total of four readers. (See *Section 4-3* for details.) This board mounts in the lower right quadrant of the board, and when it is present **all 4 readers attach to it** via its removable terminal strips. The regular reader terminals on the main board are not used when the Four Reader Board is used. The connector for this board is P3, located directly above the bottom center of the board. The Four Reader Board has its own run LED described in the LED section below. It is controlled by a special, programmable chip, called a PIC chip. The paper label on the PIC chip indicates a version number similar to the label on the PROM chips on the main board.
- A Reader Function Test is available on the N-1000-IV. A pair of jumper prongs located on the Four Reader Board and labeled *TEST* can be shorted to cause a function test . It will cause the board to generate a simulated card read from each of the four readers.
- An improved canister has more knockouts, a larger battery bracket and improved wiring space, since the board is centered in the enclosure. (The old enclosure can be field retrofitted for the new board.)
- The processor speed of 9.8304 MHz is four times faster than standard N-1000-II. This increases the speed of internal processing. The communications output is the same as the N-1000-II panels so they can be used in the same loop.
- An additional Terminal Block (TB9) has been added in the upper left quadrant of the board. This terminal block has an Earth Ground connection; a battery plus and minus (in addition to the soldered in battery wires.); AC connections 1 and 2 (there are no spade lugs for AC or battery); the Tamper and External Power Fail inputs with common terminals; and a place to tie the 485 shield if it is used.

Memory

- One memory chip is soldered to the panel and a socket is provided for another. The X boards come with two chips.

Communication

- There are both RS-485 and RS-232 communications ports in addition to the 20 milliamp port. The 485 port is selected by a change of Jumper 1 in lieu of the 20 milliamp. The RS-232 port can be used in addition to or in lieu of the other ports.
- The N-485-API-2 components are now on board the N-1000-III/IV panel eliminating the need for the separate API board. An isolated communications interface is used which is more immune to poor grounding. The terminals used are TB7 terminals 2 (+) and 3(-). Back-up of the 485 memory is also provided by the “super-cap.”
- There is an onboard 9 pin RS-232 connector to allow a direct hookup to the AUX Port. The components for the AUX Port are on all N-1000-III/IV boards, and the firmware is programmed to use it. This allows trouble shooting communication to an individual panel with a computer or terminal while the panel is still connected to the loop.

Power

- The panel sits in standby mode if there is not enough voltage for reliable operation upon power up.
- The red primary power fail light flashes rapidly on reset or power-up if the battery is too low for reliable operation.
- A 16.5 volt AC power source is now required, allowing the charging of a 12 volt battery for back-up as well as the supply of 12 Volt Reader and PIR egress power from the N-1000-III/IV.
- A 12 volt output 500 mA is available for powering 12 volt readers or PIR egress detectors. Connections for this are at TB9 terminals 7 (+) and 8 (Common).
- Connections are provided for optional 12 volt DC at TB9 terminals 2 and 3. This is a change from the N-1000-II where the 12 volt DC was connected to the AC terminals.
- Circuitry has been added to detect the drop-out and restoration voltage conditions when the panel is running from the power to the battery terminals. The processor is programmed to respond to both conditions. If the voltage on these terminals drops to its predefined level, the processor shuts the panel down. When the voltage rises to the predetermined level, the panel returns to operation. The voltage for drop out is higher (in the 10 Volt range) than it is for the N-1000-II (in the 9 Volt range).
- Battery Back Up Detector now detects switch-over on an external power supply (e.g., the PS1-12). In addition to detecting the switch-over from Primary Power to battery on the panel itself (as the N-1000-II always has) the new panel can sense if there is a switch over on an outside power source, such as the PS1-12, without the use of a relay on the outside power source.

- A special input is provided for wiring from power supplies that have a primary power fail signal. If this input point is used rather than the internal sensor described above, it must be selected by means of jumper JP-6. (1-2 = External and 2-3 = Internal. The default is for the internal sensor.)
- Detection of a primary power failure by either the internal sensor or the input from the relay on the external supply will generate an Alarm 19 not Alarm 8. Alarm Point 8 is now available for use as a standard alarm point
- Automatically resetting solid state fuses are used instead of replaceable glass fuses.
- The Green Low-V OK LED will go off to indicate low 12 Volt battery or disconnected RAM back-up (JP9).
- A special set of connectors for the AEP-3 Relay Expansion board is provided. J1 is a connector for the present AEP-3 Board design. J2 is a double connector and will be used for a future development.

Readers

- The Device Number is sent with the Card Read Transaction Message. The Card Read Transaction Message table is:

RD#nn_ _ _ _ [Card Number] etc. = Reader 1 or Keypad 1

RD#nn_ _ X _ _ [Card Number] etc. = Reader 2 or Keypad 2

RD#nn_ _ 3 _ _ [Card Number] etc. = Reader 3

RD#nn_ _ 4 _ _ [Card Number] etc. = Reader 4
- There are screw terminals for the reader cable shield connections. These are nearer to where the wires come in, eliminating the need to run the shield wire around the board.
- The default relationships between Readers, Outputs, Inputs and LEDs have changed. Readers 1 and 2 still activate Relays 1 and 2, but the default inputs for EGRESS are now 5 and 6 and the outputs for the Reader LEDs are 11 and 12 respectively. Keypads 1 and 2 function in the same manner. (As described below, the K Option is no longer needed in the initialization string because the terminals for the Keypads are not shared with inputs.) Readers 3 and 4 fire relays 3 and 4 and use outputs 13 and 14 for the Reader LEDs. The EGRESS inputs for these Relays will be 7 and 8.
- Split time zones are allowed, one time zone per reader.
- The terminals on terminal block 8 are used exclusively for 11 wire Keypads. This makes all regular inputs available even when a keypad is used. The K option is no longer needed. The P Option must still be entered for use with PINs. The wiring is the same as it was on the N-1000-II except that screw Terminal 4, which was skipped when wiring to the N-1000-II is used for the

Black (Ground) wire of the Keypad. (The Black wire was connected to screw terminal 12 on the N-1000-II.)

- Keypads 3 and 4 are no longer available. This means that when 4 readers are used, only two of them (Readers 1 and 2) can use PINs.

Inputs

- There is a separate Tamper Input located on TB-9. Tamper Alarms report as Alarm number 20. This makes Input 12 (terminal now located on TB-6) available as a regular alarm input.
- As described above the default Input Interlocks have changed slightly. 1 and 2 are still the Door Contact Inputs for Doors 1 and 2, but now Inputs 3 and 4 are the Door Contact Inputs for Relays 3 and 4. Also the Egress Inputs for doors 1-4 are Inputs 5-8 respectively.
- Each Input can be individually programmed for both Normally Open or Normally Closed and Supervised or Non-Supervised operation. There is a special command of the format:
`_W=pn_input_[SO,SC,NO,NC]<CR>`
 Where:
input = the number of the input point being set.
 SO = Supervised N.O. (Resistor in parallel with switch);
 SC = Supervised N.C. (Resistor in series with switch);
 NO = Non-supervised N.O.; and
 NC = Non-supervised N.C. (default).
- If an End Of Line Resistor is put on a point, and it is not set up as a supervised point (using one of the commands above), it will report TROUBLE whenever the resistance is connected. This should serve as a warning that the point has not been set up.
- When a point is programmed as supervised, a generic 2.2K ohm 5% tolerance resistor is used as the End Of Line resistor.
- There are several changes to the System inputs.
 - Alarm 17 Communications failure alarm, but now it reports for either 20 mA or 485 failures.
 - Alarm 18 Reserved for future reporting of an Auxiliary Communications Failure (the RS-232 port.)
 - Alarm 19 Primary Power Fail alarm as described above.
 - Alarm 20 Tamper alarm (with special terminal connections on Terminal Block 9).
 - Alarm 21 Input Ground Fault alarm. If the input is shorted to Earth Ground this alarm will be generated. (Some fault conditions may generate an ALARM rather than TROUBLE from the point, but no ground fault will be interpreted as NORMAL.)
 - Alarm 22 Reserved for future use.
 - Alarm 23 Indicates an external 5 volt reader power short circuit.

Alarm 99 Generated at restart either due to the Push Button or the watch dog timer. (This alarm cannot be stored in the history buffer.) A 99 trouble is communicated on a cold boot-up reset when the RAM memory is being initialized.

- Terminals for Inputs 9 through 16 are now on Terminal Block 6.
- Terminal Block 6 terminals 1 through 4 are Inputs 5 through 8 (as they have been), but now terminals 5 through 12 are for Inputs 9 through 16. All 16 inputs are now available whether the 10/12 wire keypads are used or not.
- AEP-5 Supervised Input Expansion Board cannot be used with the N-1000-III/IV.

Relays

- Relays are heavy duty inductive load rated. They have a maximum load rating of 30 VDC, 5 A Resistive, 2 A Inductive. They also have circuitry which is less susceptible to electrical switching noise.
- The ERB-1 Four Point Solid-State Relay Expansion Board can not be used with the N-1000-III/IV.

Jumpers

There are several functions that are controlled by jumpers. (See Section 4-9.)

<i>Number</i>	<i>Position</i>	<i>Function</i>
JP1	Jump Pins 1 & 2	Selects 20 mA communications loop.
	Jump Pins 2 & 3	Selects 485 multi-drop communications (default)
JP2	Open	Provide end of line (EOL) termination for 485 drop line. Refer to <i>Section 6-6-8</i> for details.
JP3	Open	
JP4	Jump Pins 1 & 2	Jumper is inserted for the panel at the end of the 485 multi-drop cable (default).
	Remove	Remove the jumper if the panel is not at the end of the cable or JP2 and JP3 are used. Refer to <i>Section 6-6-8</i> for details.
JP5	(Not Used)	
JP6	Jump pins 2 & 3	Onboard power fail detection selected (default).
	Jump Pins 1 & 2	Select External power fail detection.
JP7	(Not Used)	
JP8	(Not Used)	

JP9	Jump Pins 1&2 Disables clearing of RAM by JP10 (default). Remove Enables clearing the RAM by JP10.
JP10	Jump Pins 1&2 Clears RAM when power is off and JP9 is removed. Remove Will not clear RAM, allows supercap to backup memory (default).
JP11	(Not Used)

LEDs

The LEDs have been rearranged and several new ones added. (See figure B-1.)

The functions of the N-1000-III/IV LEDs are listed below.

<i>Function</i>	<i>LED</i>	<i>Color</i>	<i>Lit Indicates</i>
Relay Status 1-8		Red	Generally they are located near their respective relays and connections, except for LEDs 7 and 8, which are above and to the right of their relays. Lit indicates that its relay is energized, that is, the normally open relay contacts become closed and the normally closed relay contacts become open. Not lit indicates relay is de-energized, that is normally open and normally closed contacts are in normal state.
485 Status	9	Green	Slow flashing indicates proper 485 communications. Stays lit indicates the panel address is not found or the baud rate is incorrect. Flickers rapidly and is somewhat dim, it is an indication that there has been a degradation in the bus signal. Rapid flashing (between blinking slowly and flickering rapidly) is an indication that there has been a loss of communication from the panel to the PCI or HUB.
+ 12 V OK	10	Green	The 12 volt power is available for supplying readers or PIR egress devices.
+ 5 V Ext. OK	11	Green	Panel is supplying + 5 VDC output for reader/ keypad power.
Low-Voltage OK	12	Green	Battery voltage acceptable and RAM back-up available.
Ground Fault	13	Red	Continuity between earth ground and the panel's signal common.
Run	14	Green	Running Status indicator, functions as it always has. Pulsing indicates N-1000 microprocessor operating properly; not lit or not pulsing indicates malfunction. When the Power Fail and Run LED flash

alternately, it indicates that an incorrect PLD chip is present in U35.

Power Fail	15	Red	Loss of primary power with panel powered by 12 VDC battery (fast flashing indicates battery charge is too low to operate panel even with primary power available). Also flashes alternately with the RUN LED when there is an incorrect PLD as described above.
Com Loop	16	Yellow	Lit indicates the output terminals have a closed circuit; flickering off indicates outgoing transmissions are occurring.
485-TX:	17	Red	Periodic quick flashing indicates the panel is communicating on the 485 bus.
Four Reader Board Status	Green		Quick flash (strobe like) indicates processor running, long flash indicates card read, very long flash indicates reset due to error or power problem.

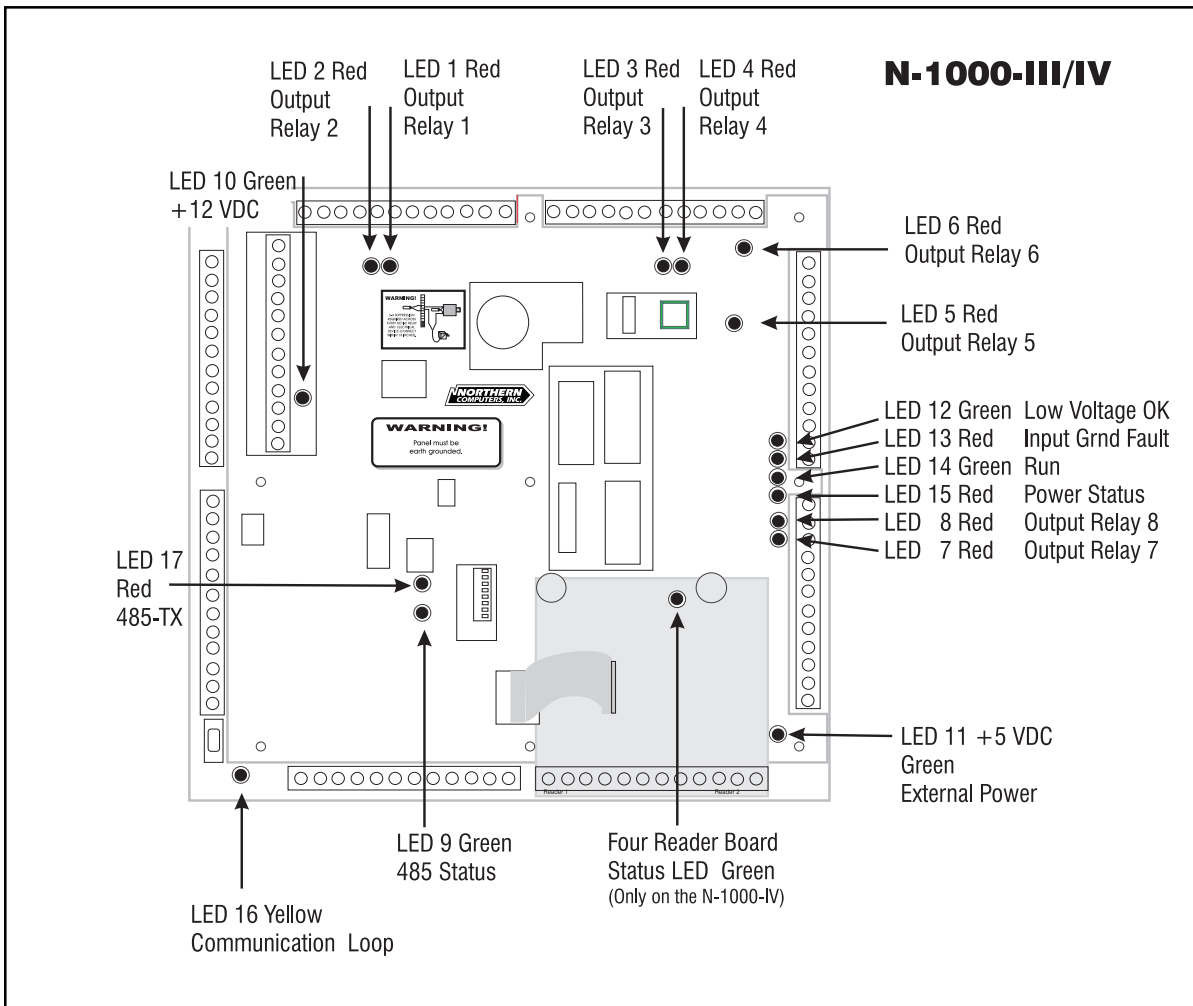

Figure B-1. Location of LEDs.

Appendix C: Troubleshooting

Problem: The N-1000-III/IV control panel experiences “lock-ups.”

Solution: Press the restart button to reset the panels and check the following:

- Verify that a circular time zone link or interlock does not exist in the programming of the panel. See *Appendix A* or software operator's manual for programming details.
- Verify that proper panel/reader grounding procedures are followed. Improper grounding is a primary cause of panel lock-ups. Refer to *Section 8* for grounding guidelines. In environments where there is severe electrical noise, the shields should be grounded outside of the enclosure and a separate ground wire (12 gauge) should be used for the system ground, removing the individual panel grounds. Ground each panel to the single system ground wire and ground the single system ground wire at one point only.
- Confirm the installation of the two-piece S-4 Suppressor Kits with every electrical switching device run through a panel relay. Refer to *Section 7* for Suppressor Kit information.
- If all above attempts fail to correct the problem, completely power down the panel. Refer to *Section 9* for power-down instructions. After complete power-down, move jumper JP9 to Open and JP10 to Close. This will clear all RAM while the panel is powered-down. After a 60 seconds return JP9 to close and JP10 to open. This brings the N-1000 back to its factory default settings.

Problem: Communication from the system programming device to the control panel(s) is not established (20 mA).

Solution: When programming in a data terminal mode (Hyperterminal, Procomm, etc.) or printer programmer, press the SPACE BAR followed by the ENTER key to verify communication. If communication is established, each panel in the loop returns an S?. If communication is not established, check the following:

- Verify communication loop wiring. Refer to *Section 6* for panel and multipanel loop wiring specifications.
- A locked-up panel in a 20 mA configuration causes communication problems. Starting with the last (physical) panel in the loop and working back to the first (physical) panel, press the restart button on all control panels in the loop. Check communication at the programming device after every restart to locate the panel which is causing the lock-up. Check for proper grounding as mentioned above, and S-4 suppressor usage.
- Verify that the baud rate of all control panels matches that of the programming device. Refer to *Section 4* for baud rate DIP switch settings.
- Verify C-100 operation by shorting the red and white wires together, then shorting the black and green wires together (disconnecting these wires from the

loop). Enter into the terminal emulation program. Type some letters and press the ENTER key. The letters will echo back on the screen if the C-100 is working properly. See the *C-100-A1 Manual* for further details.

Problem: A card number is not transmitted to the programming device when a card is run through a reader.

Solution: Check the following:

- Verify communication from the N-1000 to the programming device.
- Confirm the panel is not operating in the buffered mode.
- For readers requiring + 5 VDC power (from the control panel), verify voltage at the reader is + 4.9 to + 5 VDC.
- For readers requiring + 12 VDC power, verify output of external power supply.
- Verify card reader wiring. Refer to *Section 6* for general card reader wiring details.
- Wire the card readers directly to the N-1000 (to eliminate reader to panel distance). If card reads are then transmitted, the problem is due to environmental factors.
- Determine whether the problem is related to the card reader in use or the N-1000 reader port in use. Wire the card reader in question to an N-1000 reader port that is known to operate properly or wire a card reader known to operate properly to the reader port in question and test with known card.

Problem: A keycode is not transmitted to the programming device when entered at an Eleven-conductor Keypad.

Solution: Check the following:

- Verify communication from the N-1000 to the programming device.
- Confirm the panel is not operating in the buffered mode.
- Verify the keypad pound (#) key is pressed after entering the keycode. Pressing the # key is necessary for keycode transmission.
- To test the operation of an N-1000 keypad port without using a keypad, simulate keystrokes with a three-way jumper. To simulate a keystroke, connect one end of the jumper to a row terminal, one end to a column terminal and momentarily touch the third end to the keypad ground terminal. See *Eleven-Conductor Keypad* instructions (*Section 6*) for 2 of 7 matrix terminal information.

Example: Simulate pressing the 4 key.

Connect one end of the jumper to the brown wire terminal (column 1, TB8-1).

Connect the second end of the jumper to the purple wire terminal (row 2, TB8-6).

Momentarily touch the third end of the jumper to the keypad ground terminal (TB8-4). (Refer to Section 6-3)

Simulate pressing the pound (#) key.

Connect one end of the jumper to the green wire terminal (column 3, TB8-3).

Connect the second end of the jumper to the orange wire terminal (row 4, TB8-8).

Momentarily touch the third end of the jumper to the keypad ground terminal (TB8-4). (Refer to Section 6-3.)

Individually simulate the pressing of each keypad key, as described above, to verify operation of the keypad port.

N1000-III/IV Self-Test Capability

The N-1000-III/IV firmware (version 08.01.29 or later) has a built-in test capability that can be used to check the functioning of most of the circuit board's hardware. (The parts of the main circuit which are not checked with the built-in test mode include the entire RS-485 interface circuit—except the watch-dog timer).

Before conducting the self tests make sure that the Green +5v *EXT OK* and the 12 V *OK* status LEDs are both ON. Disconnect the ribbon cable going to the Four Reader Board (if present). Then perform the following DC voltage measurements:

<i>Test Point w/reference to Common Test Conditions</i>	<i>Nominal Value</i>	<i>Acceptable Range</i>
Battery (+) TB9-2 to TB9-3	Without battery	13.80 VDC
12 VDC output TB9-7 to TB9-8	No Load	13.70 to 13.90 VDC
5 VDC output TB5-4 to TB5-5	No Load	13.80 VDC
		4.95 to 5.05 VDC

To enable the built-in test, move all of the DIP switches to the ON position, and then reset the board. In the test mode the main micro's watchdog timer is disabled (but not the 485 processor's watchdog). The 485 com-port is not functional in the self-test mode so set jumper JP1 in the 20 mA position (1 & 2).

The circuit board will now function as follows:

1. Once after reset output Relays 1 through 8 will sequentially turn ON for a half second each. (Note: If no RAM is available then the built-in self test will stop after this step.)
2. The LOOP-ENABLE Relay (K9) will turn off for 4 seconds after reset and then a short stream of the ASCII *U* characters will be outputted followed by the message *Self Test Mode* on the RS-232 (P1) Port (set at 9600 baud 8 data, 1 stop bit and no parity). Characters inputted on either port will be echoed out the other port.
3. The RUN LED (and also the latch-IC U17 pin 16 output) follows the state of the Tamper Switch input TB9-9 (Closed = Low/Off).

4. The POWER STATUS LED (and also the latch-IC U17 pin 15 output) follows the state of the microprocessor's Primary-Power-Status input (with JP6 in 1&2 and the Ext. P-Status input (TB9-11) closed or with JP6 in 2&3 = LED On).
5. The Reader #1 LED output (TB5-1) and the AEP-3 STROBE (J1-1) line follows the state of the micro's Low-V input (LOW-V LED On = Reader LED output Low and J1-1 High /open). The Low-V signal can be activated by moving jumper JP9 to location JP10 and then cycle the power source off and then back on. Restore JP9 to change the state. Shorting out the battery terminals (TB9-2 to TB9-3) will also generate a Low-V signal.
6. The Reader 2 LED output (TB5-8) and the AEP-3 CLOCK (J1-3) line follows the state of the micro's GFAULT input (GF-LED On = Reader LED output Low and J1-3 High /open).
7. The microprocessor's output port B follows the input port A as follows;
 - 7.1. PB0 (Input Mux-A line at U32-10) follows the state of input port PA0 (TB8-1).
 - 7.2. PB1 (Input Mux-B line at U32-9) follows input port PA1 (TB8-2) (Closed = High).
 - 7.3. PB2 (LED#3 TB5-10) follows the state of input port PA2 (TB8-3). (Closed = Low).
 - 7.4. PB3 (LED 4 TB5-11) follows the state of input port PA4 (TB8-5). (Closed = Low).
 - 7.5. PB4 (Keypad 1 Select TB8-10) follows the state of input port PA5 (TB8-6).
 - 7.6. PB5 (Keypad 2 Select TB8-11) follows the state of input port PA6 (TB8-7).
 - 7.7. PB6 is the Tamper Switch input and is not tested in this section.
 - 7.8. PB7 (AEP-3 Data J1-2) follows the state of input port PA7 (TB8-8). (Closed= Low)
8. Relay Outputs (continuously after the initial reset sequencing):
 - 8.1. With the TAMPER Switch input circuit OPEN (Tamper Switch not depressed) and the /Primary-Power-Status input LOW (JP6 open) the relay outputs 1 through 8 will follow the settings of the S1 dip-switch positions 1 through 8.
 - 8.2. With the TAMPER Switch input circuit OPEN (Tamper Switch not depressed) and the /Primary-Power-Status input HIGH (JP6 jumper 2&3) the relay outputs 1 through 8 will follow the state of the Keypad Inputs in reverse order (TB8-1 = Relay 8). When the Keypad input terminals are connected to common the respective Relays will turn ON with the exception that grounding P3-10 is required to turn ON Relay 5. If the Four Reader Board is connected then Relay 5 will oscillate on and off.

8.3. With the TAMPER Switch input circuit CLOSED (Tamper Switch depressed) and the /Primary-Power-Status input HIGH (JP6 jumper 2&3) the relay outputs 1 through 8 will follow the state of the Reader Data inputs and RAM memory test as follows:

- 8.3.1. Relay 1 pulses when Reader 2, Data-0 (TB5-6) is tied to common.
- 8.3.2. Relay 2 energizes when Reader 2, Data-1 (TB5-7) is tied to common.
- 8.3.3. Relay 3 pulses when Reader 1, Data-0 (TB5-3) is tied to common.
- 8.3.4. Relay 4 energizes when Reader 1, Data-1 (TB5-2) is tied to common.
- 8.3.5. Relays 5 and 6 both ON indicate that memory chip U7 is OK.
- 8.3.6. Relays 7 and 8 both ON indicate that memory chip U6 is OK.

8.4. With the TAMPER Switch input circuit CLOSED (Tamper Switch depressed) and the /Primary-Power-Status input LOW (JP6 open) the relay outputs 1 through 8 will follow the state of the supervised inputs as follows; (Note: EOL = 2.2K ohms)

Resulting Relay States

Input/TB	Input Condition	R1	R2	R3	R4	R5	R6	R7	R8
----------	-----------------	----	----	----	----	----	----	----	----

With TB8-1 & TB8-2 both OPEN:

Input 1	Open							Off	On
TB7-4	EOL							Off	Off
	Closed							On	Off
Input 5	Open					Off	On		
TB6-1	EOL						Off	Off	
	Closed						On	Off	
Input 9	Open				Off	On			
TB6-5	EOL				Off	Off			
	Closed				On	Off			
Input 13	Open		Off	On					
TB6-9	EOL		Off	Off					
	Closed		On	Off					

With TB8-1 to Common & TB8-2 OPEN:

Input 2	Open							Off	On
TB7-5	EOL							Off	Off
	Closed							On	Off
Input 6	Open						Off	On	
TB6-2	EOL						Off	Off	
	Closed						On	Off	
Input 10	Open				Off	On			
TB6-6	EOL				Off	Off			
	Closed				On	Off			
Input 14	Open	Off	On						
TB6-10	EOL	Off	Off						
	Closed	On	Off						

Resulting Relay States (continued)

<u>Input/TB</u>	<u>Input Condition</u>	<u>R1</u>	<u>R2</u>	<u>R3</u>	<u>R4</u>	<u>R5</u>	<u>R6</u>	<u>R7</u>	<u>R8</u>
-----------------	------------------------	-----------	-----------	-----------	-----------	-----------	-----------	-----------	-----------

With TB8-1 OPEN & TB8-2 to Common:

Input 3	Open							Off	On
TB7-6	EOL							Off	Off
	Closed							On	Off
Input 7	Open					Off	On		
TB6-3	EOL					Off	Off		
	Closed					On	Off		
Input 11	Open			Off	On				
TB6-7	EOL			Off	Off				
	Closed			On	Off				
Input 15	Open	Off	On						
TB6-11	EOL	Off	Off						
	Closed	On	Off						

With TB8-1 & TB8-2 both to Common:

Input 4	Open							Off	On
TB7-7	EOL							Off	Off
	Closed							On	Off
Input 8	Open					Off	On		
TB6-4	EOL					Off	Off		
	Closed					On	Off		
Input 12	Open			Off	On				
TB6-8	EOL			Off	Off				
	Closed			On	Off				
Input 16	Open	Off	On						
TB6-12	EOL	Off	Off						
	Closed	On	Off						

Index

Symbols

20 mA Communication 6-7 – 6-14
485 Communication 6-12 – 6-14
Bias and EOL 6-18

A

Access control 1-1
AEP-3 6-8
Alarm input points 5-4. *See also* Input Points
wiring req. 6-7
Anti-passback 5-1, 5-1 – 5-14

C

C-100-A1 Converter
overview 2-4
Cable
NCI part numbers 6-19
specifications 6-18
Card Reader/Keypad
operation 5-1
Card reader/keypad
grounding 6-4
Card readers
wiring 4-20, 6-1
Commands A-5 – A-22
A Command A-5
C Command A-6
D Command A-8
E Command A-9
F Command 5-1, A-10
G Command A-12
H Command A-13
I Command A-13
L Command A-14
M Command A-15
N Command A-16
O Command A-17
P Command A-18
R Command A-18
T Command A-19
V Command A-19
W Command A-20
Z Command A-21

Communications
wiring 6-7

Connectors 4-15

D

Digital Redundant Loop Adapter 6-17
DIP switch settings 4-12 – 4-13

E

Eleven conductor keypads 6-5
Error codes A-4
Error messages A-1

F

Format command 5-1
Four Reader Board
layout 4-2 – 4-3
Free egress. *See* Input point/output point interaction

H

Hardware specifications 3-1

I

Input point configuration 5-4
Input point/output point interaction 5-6
auto-relock 5-14
time zone-controlled doors 5-14
with anti-passback 5-8
with free egress 5-8
without anti-passback 5-6
Installation information
additional 4-18

J

Jumpers 4-14

L

LEDs 4-16
Locks and suppression 7-1

N

N-1000-III/IV
overview 2-1
N-1000-III/IV compared to N-1000-II B-1 – B-7
N-485-PCI-2 or HUB-2
overview 2-4

O

Operation 5-1
OR'ing of Inputs A-21
Output Groups by readers A-22
Output points 5-5. *See also* Relay Output Points

P

Panel layout 4-1
Parameter variables A-2
Power 9-1
Programming A-1
Programming devices 2-2 – 2-4
Programming order A-5
PROM chip 4-18
PROM versions 2-4

R

RAM chip 4-18
Readers
 wire terminations 4-6
 wiring requirements 6-1 – 6-7
Redundant loop adapter 6-17
 see digital redundant loop adapter
Relay output points 5-5
 wiring requirements 6-7
Restart button 4-18
RS-232 serial communication ports
 configurations 6-20

S

Self-test C-3
System overview 2-1

T

Terminal blocks
 TB1, 2, 3, 4 4-4
 TB5 4-6
 TB6 4-6
 TB7 4-8
 TB8 4-10

TB9 4-10
Troubleshooting C-1
 circular time zone C-1
 panel lock-up C-1

W

Wiring 6-1 – 6-14
 AEP-3 6-8
 alarm input points 6-7
 C-100-A1 6-7
 card readers 4-6, 4-20, 6-1
 communication 6-7
 eleven conductor keypads 6-5
 example diagram 4-20
 four reader board 6-3
 N-485-HUB-2 6-13
 N-485-PCI-2 6-12
 relay output points 6-7

No.	Position	Function
JP 1	Jump 1 & 2	20 mA communications
JP 2	Open	485 communications (default)
JP 3	Open	Jumper on if the N-485-PCI-2 is not at the end of the multi-drop cabling (JP 4 must also be removed). Leave open if N-485-PCI is at end of dropline.
JP 4	Jump 1 & 2	Both jumpers are inserted for the panel at the end of the 485 multi-drop cable (default)
	Remove	Remove the jumper if the panel is not at the end of the cable or JP2 and JP3 are used.
JP 6	Jump 2 & 3	Onboard power fail detection selected (default).
	Jump 1 & 2	Select External power fail detection.
JP 9	Jump 1 & 2	Disables clearing of RAM by JP10 (default).
	Remove	Remove/Enables clearing the RAM by JP10.
JP 10	Jump 1 & 2	Clears RAM when power is off for at least 60 seconds and JP9 is removed.
	Remove	Will not clear RAM, allows supercap to backup memory (default).

JUMPER SETTINGS

NOTE: Separate Fire Release Contact is required

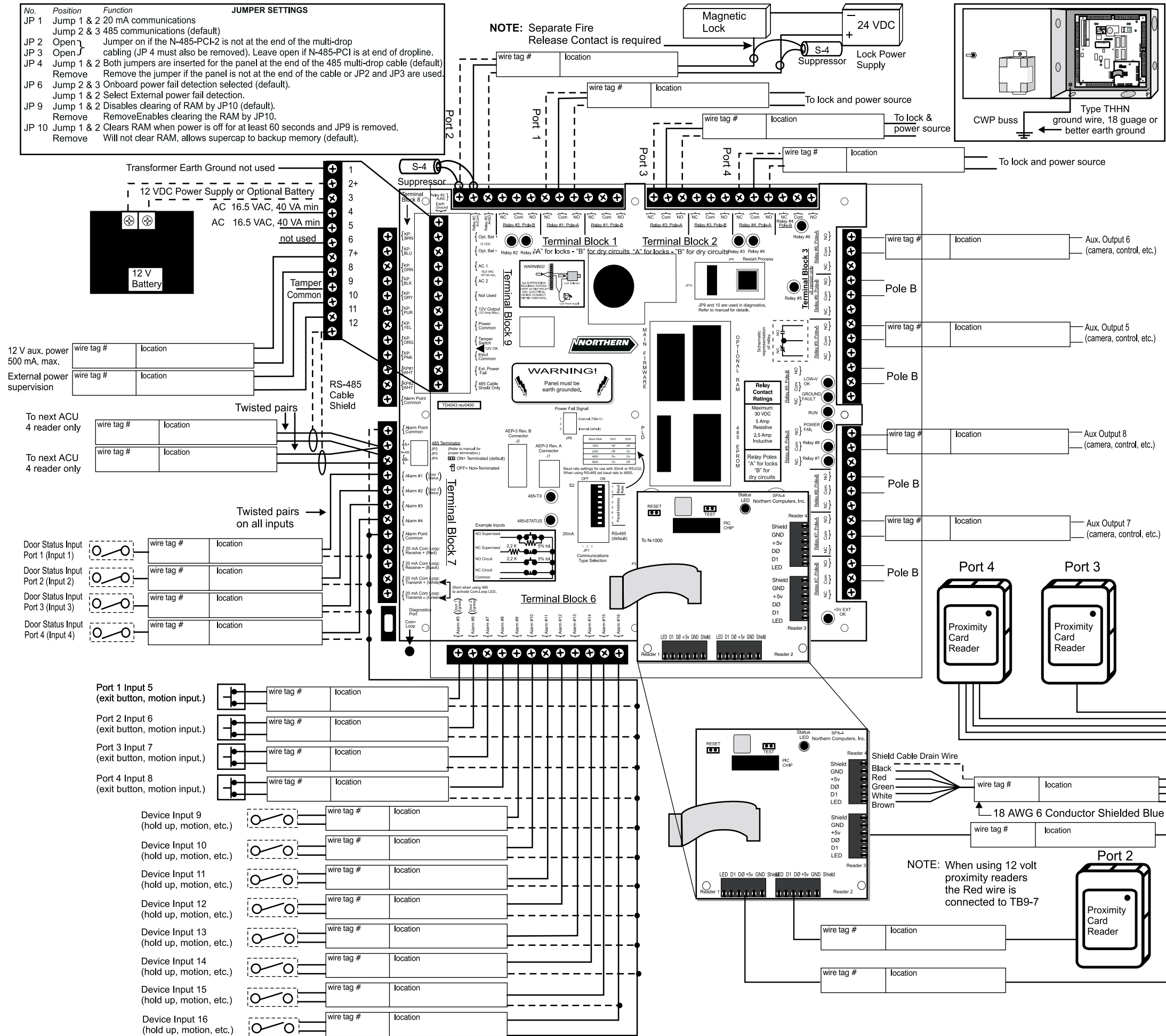

PROJECT: _____ Date: _____
 Technician: _____ Sub-Cont: _____
 Panel Name: _____ Address: _____ Loop #: _____
 Panel Loc: _____ Interface Loc: _____
 A.C. Breaker Loc: _____ Ground Loc: _____

READERS:
 Port 1 Loc: _____ In _____, Out _____
 Port 2 Loc: _____ In _____, Out _____
 Port 3 Loc: _____ In _____, Out _____
 Port 4 Loc: _____ In _____, Out _____

INPUT POINTS

1. Type: Dr Stat P-1 Loc: _____	EOL Loc: _____
2. Type: Dr Stat P-2 Loc: _____	EOL Loc: _____
3. Type: Dr Stat P-3 Loc: _____	EOL Loc: _____
4. Type: Dr Stat P-4 Loc: _____	EOL Loc: _____
5. Type: Egress P-1 Loc: _____	EOL Loc: _____
6. Type: Egress P-2 Loc: _____	EOL Loc: _____
7. Type: Egress P-3 Loc: _____	EOL Loc: _____
8. Type: Egress P-4 Loc: _____	EOL Loc: _____
9. Type: _____ Loc: _____	EOL Loc: _____
10. Type: _____ Loc: _____	EOL Loc: _____
11. Type: _____ Loc: _____	EOL Loc: _____
12. Type: _____ Loc: _____	EOL Loc: _____
13. Type: _____ Loc: _____	EOL Loc: _____
14. Type: _____ Loc: _____	EOL Loc: _____
15. Type: _____ Loc: _____	EOL Loc: _____
16. Type: _____ Loc: _____	EOL Loc: _____

RELAY OUTPUTS

1. Type: A _____ Port 1 Lock _____ Pole B _____
2. Type: A _____ Port 2 Lock _____ Pole B _____
3. Type: A _____ Port 3 Lock _____ Pole B _____
4. Type: A _____ Port 4 Lock _____ Pole B _____
5. Type: A _____ Pole B _____
6. Type: A _____ Pole B _____
7. Type: A _____ Pole B _____
8. Type: A _____ Pole B _____

PROJECT _____

TITLE _____

DESCRIPTION _____

REV.	DESCRIPTION	DATE	BY

FULL FILE NAME _____ DATE _____

DRAWING _____ OF _____ DRAWN BY _____

NORTHERN COMPUTERS, INC. 5007 South Howell Avenue
 Milwaukee, WI 53207
 www.nciaccess.com

TD4131 rev0400 (page 1 of 1)



K4788



Leaders in Access Control Technology

5007 S. Howell Avenue
Milwaukee, WI 53207
www.nciaccess.com

Phone: (414) 769-5980
(800) 323-4576
Fax: (414) 769-5989

ADEMCO
GROUP
INTEGRATED SYSTEMS