

# MCT-220

## Wireless Emergency Button



# Visonic

## User Guide

## 1. INTRODUCTION

### 1.1 General

The MCT-220 enables people, for example senior citizens in their home environment, to transmit an emergency call when they are at some distance from their communication unit.

### 1.2 Additional Features

- Can be used for panic alarm, when used with a Visonic Amber or PowerMax family system.
- Can be used for X-10 devices activating when used with a Visonic PowerMax family system.
- An auxiliary sensor can be connected to the MCT-220. When the sensor is in an alarm state, the MCT-220 sends an alarm message from its auxiliary channel.
- Enables people to answer incoming calls when the telephone is out of reach, when used with a Visonic Amber family system.
- MCT-220 button pressing period - 2 seconds or 300 milliseconds (selectable by an internal function selector).



Figure 1 – MCT-220

- Supervision signal is regularly transmitted to the communication unit.
- In low battery voltage state, an alarm message is sent to the communication unit and the MCT-220 button blinks during transmission.
- Push button back light can be switched On/Off by an internal function selector.
- Auxiliary input E.O.L / Normally Close type can be selected by an internal function selector.
- Auxiliary input alarm restore message can be enabled / disabled (selected by an internal function selector).
- Water resistant.

## 2. SPECIFICATIONS

### GENERAL

**Compatibility:** Compatible with all Visonic control panels and receivers.

**Operating Frequencies (MHz):** 315, 433.92, 868.95, 869.2125 or 869.

### ELECTRICAL

**Internal Battery:** 3V battery type CR123

**Current Consumption:** 35 mA (during transmission), 20µA in standby mode.

**Battery Life Expectancy:** 5 years (for one alarm per day)

### ENVIRONMENTAL

**Operating Temperature:** 0° to 50°C (32° to 122°F)

**Standards:** Designed to comply with FCC CFR 47 Part 15, UL 1637, Directive 1999/5/EC, EN 50131-2, Grade 2, Class II, RSS-210.

### PHYSICAL

**Dimensions (Diameter x H):** 90 x 35 mm (3-1/2 x 1-3/8 in)

**Weight:** 110g (3.9 oz.)

**Color:** White

**Note:** The manufacturer is not responsible for any radio or TV interference caused by unauthorized modifications to this equipment. Such modifications could void the user's authority to operate the equipment.

**Compliance with standards (Europe):** ETSI EN 301 489-3 V1.4.1, EN 50130-4, & A1: & A2, EN 300 220-2 V2.1.2, EN 300 220-1 V2.1.1, EN 50131-1, Grade II, Class II, EN 60950-1

This device complies with Part 15 of the FCC Rules and RSS-210 of Industry and Science Canada. Operation is subject to the following two conditions: (1) This device may not cause harmful interference, and (2) this device must accept any interference received, including interference that may cause undesired operation.

This device complies with the essential requirements and provisions of Directive 1999/5/EC of the European Parliament and of the Council of 9 March 1999 on radio and telecommunications terminal equipment.

## 3. PREPARATION FOR USE

### 3.1 Cover Removal

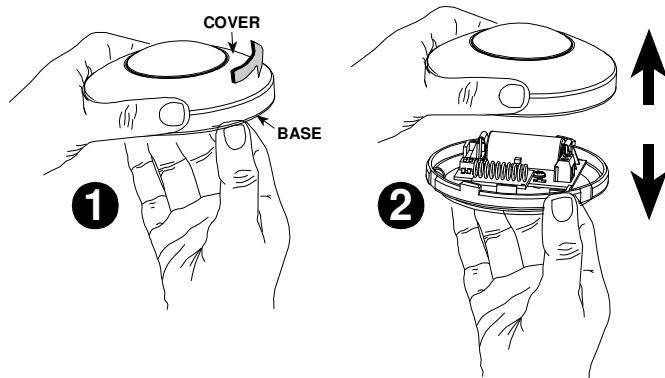

Figure 2 – Cover Removal

### 3.2 Function Selector Setting

The MCT-220 has a 4 lever switch (see Fig. 3). Each switch lever allows you to select one of two options.

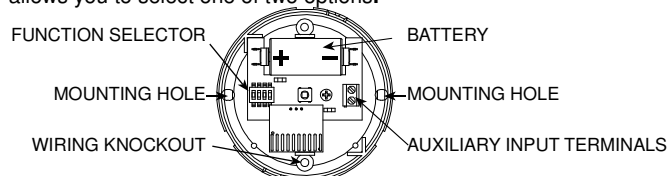

Figure 3 – Internal View

Set the switches as desired (see table 1) prior to applying power. Use a ball point pen or another pointed object to shift the switch levers. The **ON** position is indicated on the switch body.

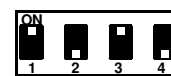

Figure 4  
Function Selector

Table 1. Function Selector Description

	Function	Pos.	Selected Option	Default
SW1	Back light ON/OFF	ON	Button's back light ON	ON
		OFF	Button's back light OFF	
SW2	Aux. input type selector (*)	ON	Aux. input is E.O.L. (47 kΩ)	OFF
		OFF	Aux. input is N.C.	
SW3	Auxiliary input restore reports enable/disable (**)	ON	Aux input Restore events are reported	ON
		OFF	Aux. input restore events are not reported	
SW4	Pressing period of push button	ON	2 seconds	OFF
		OFF	300 milliseconds	

(\*) SWITCH SW2 determines whether the auxiliary input will behave as a 47kΩ end-of-line (E.O.L.) input or as a normally closed (N.C.) input.

(\*\*) SWITCH SW3 determines whether the MCT-220 will report a restore event when the auxiliary input restores from an alarm condition.

### 3.3 Battery Insertion

Insert battery (see Figure 3) – Verify proper polarity.

**Caution!** Risk of explosion if battery is replaced by an incorrect type. Dispose of used batteries according to the manufacturer's instructions.

## 4. INSTALLATION

### 4.1 Wall Mounting

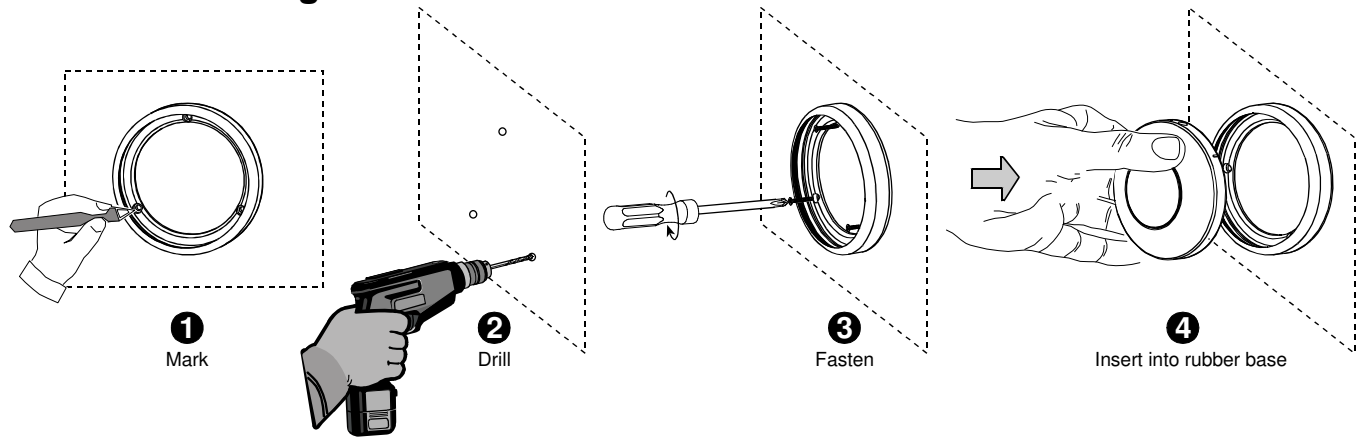

Figure 5 – Wall Mounting

### 4.2 Desktop Mounting

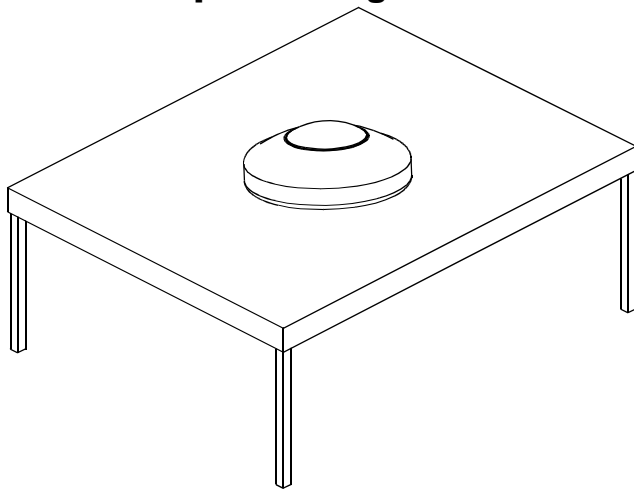

Figure 6 – Desktop Mounting

### 4.3 Auxiliary input Wiring

Connect the 2 auxiliary device wires to the proper AUXILIARY terminals GND and IN1 - see figure 3.

### 4.4 Enrolling

The MCT-220 and its auxiliary input should be enrolled into the communication unit memory, in order that the communication unit will be able to identify their signals.

If the MCT-220 is used with PowerMax family, refer to the relevant installer / programming guide, ENROLLING WIRELESS DEVICES section. If the MCT-220 is used with AMBER, refer to the HHPC software user guide.

When you are instructed to initiate transmission:

- A. For the MCT-220 enrolling, press the MCT-220 button.
- B. For the Auxiliary input enrolling, simulate an alarm event via the auxiliary detector.

### 4.5 Test

Perform the following actions and verify that the communication unit properly responds:

- A. Press the MCT-220 button.
- B. Simulate an event from the auxiliary input.

#### WARRANTY

Visonic Limited (the "Manufacturer") warrants this product only (the "Product") to the original purchaser only (the "Purchaser") against defective workmanship and materials under normal use of the Product for a period of twelve (12) months from the date of shipment by the Manufacturer.

This Warranty is absolutely conditional upon the Product having been properly installed, maintained and operated under conditions of normal use in accordance with the Manufacturer's recommended installation and operation instructions. Products which have become defective for any other reason, according to the Manufacturer's discretion, such as improper installation, failure to follow recommended installation and operational instructions, neglect, willful damage, misuse or vandalism, accidental damage, alteration or tampering, or repair by anyone other than the manufacturer, are not covered by this Warranty.

The Manufacturer does not represent that this Product may not be compromised and/or circumvented or that the Product will prevent any death and/or personal injury and/or damage to property resulting from burglary, robbery, fire or otherwise, or that the Product will in all cases provide adequate warning or protection. The Product, properly installed and maintained, only reduces the risk of such events without warning and it is not a guarantee or insurance that such events will not occur.

**THIS WARRANTY IS EXCLUSIVE AND EXPRESSLY IN LIEU OF ALL OTHER WARRANTIES, OBLIGATIONS OR LIABILITIES, WHETHER WRITTEN, ORAL, EXPRESS OR IMPLIED, INCLUDING ANY WARRANTY OF MERCHANTABILITY OR FITNESS FOR A PARTICULAR PURPOSE, OR OTHERWISE. IN NO CASE SHALL THE MANUFACTURER BE LIABLE TO ANYONE FOR ANY CONSEQUENTIAL OR INCIDENTAL DAMAGES FOR BREACH OF THIS WARRANTY OR ANY OTHER WARRANTIES WHATSOEVER, AS AFORESAID.**

**THE MANUFACTURER SHALL IN NO EVENT BE LIABLE FOR ANY SPECIAL, INDIRECT, INCIDENTAL, CONSEQUENTIAL OR PUNITIVE DAMAGES OR FOR LOSS, DAMAGE, OR EXPENSE, INCLUDING LOSS OF USE, PROFITS, REVENUE, OR GOODWILL, DIRECTLY OR INDIRECTLY ARISING FROM PURCHASER'S USE OR INABILITY TO USE THE PRODUCT, OR FOR LOSS OR DESTRUCTION OF OTHER PROPERTY OR FROM ANY OTHER CAUSE, EVEN IF MANUFACTURER HAS BEEN ADVISED OF THE POSSIBILITY OF SUCH DAMAGE.**

**THE MANUFACTURER SHALL HAVE NO LIABILITY FOR ANY DEATH, PERSONAL AND/OR BODILY INJURY AND/OR DAMAGE TO PROPERTY OR OTHER LOSS WHETHER DIRECT, INDIRECT, INCIDENTAL, CONSEQUENTIAL OR OTHERWISE, BASED ON A CLAIM THAT THE PRODUCT FAILED TO FUNCTION.**

However, if the Manufacturer is held liable, whether directly or indirectly, for any loss or damage arising under this limited warranty, **THE MANUFACTURER'S MAXIMUM LIABILITY (IF ANY) SHALL NOT IN ANY CASE EXCEED THE PURCHASE PRICE OF THE PRODUCT**, which shall be fixed as liquidated damages and not as a penalty, and shall be the complete and exclusive remedy against the Manufacturer. When accepting the delivery of the Product, the Purchaser agrees to the said conditions of sale and warranty and he recognizes having been informed of.

Some jurisdictions do not allow the exclusion or limitation of incidental or consequential damages, so these limitations may not apply under certain circumstances.

The Manufacturer shall be under no liability whatsoever arising out of the corruption and/or malfunctioning of any telecommunication or electronic equipment or any programs.

The Manufacturer's obligations under this Warranty are limited solely to repair and/or replace at the Manufacturer's discretion any Product or part thereof that may prove defective. Any repair and/or replacement shall not extend the original Warranty period. The Manufacturer shall not be responsible for dismantling and/or reinstallation costs. To exercise this Warranty the Product must be returned to the Manufacturer freight pre-paid and insured. All freight and insurance costs are the responsibility of the Purchaser and are not included in this Warranty.

This warranty shall not be modified, varied or extended, and the Manufacturer does not authorize any person to act on its behalf in the modification, variation or extension of this warranty. This warranty shall apply to the Product only. All products, accessories or attachments of others used in conjunction with the Product, including batteries, shall be covered solely by their own warranty, if any. The Manufacturer shall not be liable for any damage or loss whatsoever, whether directly, indirectly, incidentally, consequentially or otherwise, caused by the malfunction of the Product due to products, accessories, or attachments of others, including batteries, used in conjunction with the Products. This Warranty is exclusive to the original Purchaser and is not assignable.

This Warranty is in addition to and does not affect your legal rights. Any provision in this warranty which is contrary to the Law in the state or country where the Product is supplied shall not apply.

**Warning:** The user must follow the Manufacturer's installation and operational instructions including testing the Product and its whole system at least once a week and to take all necessary precautions for his/her safety and the protection of his/her property.

1/08



#### W.E.E.E. Product Recycling Declaration

For information regarding the recycling of this product you must contact the company from which you originally purchased it. If you are discarding this product and not returning it for repair then you must ensure that it is returned as identified by your supplier. **This product is not to be thrown away with everyday waste.** Directive 2002/96/EC Waste Electrical and Electronic Equipment.



**Visonic**

EMAIL: info@visonic.com

INTERNET: www.visonic.com

©VISONIC LTD. 2013 MCT-220 user guide D-301850 (Rev 3, 6/13)

