

**ASSA ABLOY**

**M670/M680 MAGNALOCK® SERIES Installation Instructions**

**Table of Contents**

Specifications	_____	2
Configuring Options	_____	3
Installation Guide	_____	6
Wiring Diagram	_____	14
Error Codes	_____	16

Scan this QR Code for a guided installation video.



Alternatively Quick Clips are available in each section.

**Package Contents**

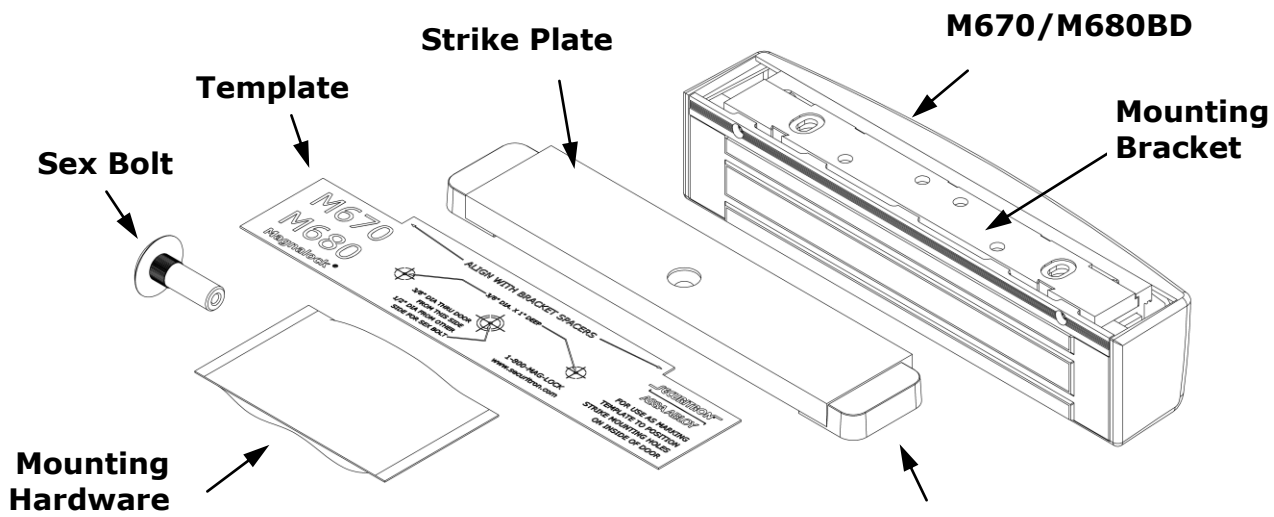

**Note:** Endcaps provided for Model 680 only.

**Mounting Hardware**

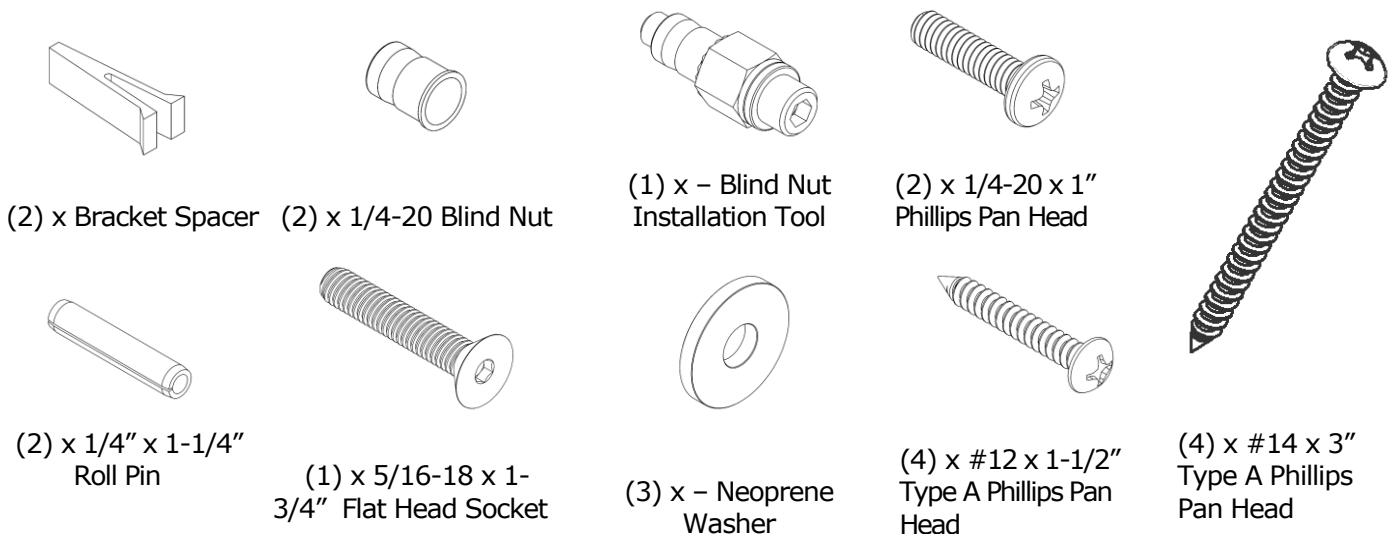

## Recommended Tools

Masking Tape	#0, #1 and #2 Phillips Screwdrivers	Hammer
Measuring Device	1/2" Open End or Crescent Wrench	Pencil/Pen
Center Punch	Wire Strippers/Cutter	Multimeter
Fish Tape or Lead Wire	3/16" Hex (Allen) Wrench	

Drill bits: 3/16", 7/32" (wood frames only), 3/8", 1/2"

## M670 / M680BD Specifications

Mechanical	Electrical	Environmental (Recommended)
<p><b>Physical Size:</b>                      Height: 2-1/2" [66mm]                      Depth: 2-1/2" [66mm]                      Length: 11-1/2" [292mm]</p> <p><b>Shipped Weight:</b>                      Weight: 13 lbs</p> <p><b>Holding Force (Maximum)</b>                      1,100 Lbs. [500kg]</p>	<p><b>Input Voltage</b>                      12/24 VDC</p> <p><b>Current</b>  <b>M670</b>                      12VDC/575mA (±10%)                      24VDC/275mA (±10%)  <b>M680BD</b>                      12VDC/550mA (±10%)                      24VDC/300mA (±10%)</p> <p><b>Tamper Switch Rating</b>                      Voltage – 30VDC (Maximum)                      Current – 1 Amp</p> <p><b>DPS Rating (M680 only)</b>                      Voltage – 30VDC                      (Maximum) Current – 125mA</p>	<p><b>Operating Temperature</b>                      32°F to 110°F [0°C to 43°C]</p> <p><b>Humidity</b>                      10% to 90% RH</p>

## Magnalock Preparation and Installation

### Pre-Installation Survey

Before installing the Magnalock, the mounting location should be determined and assessed for the following:

- Physical strength of the frame should be strong enough to meet or exceed the holding force of the Magnalock
- Frame and vicinity should offer protection for the wiring to prevent vandalism
- Door should be inspected for any obstacles that may interfere when mounting the strike plate
- The Magnalock M670/M680 comes with factory default mounting for use with an outswing door. Please contact Securitron for available brackets for other installation configurations.

# Magnalock Preparation

- Using a Phillips screwdriver, remove the two (2) screws securing the cover as shown. Remove the cover to provide access to the circuit board on the back of the magnet. The screws should be saved to re-attach the cover later.

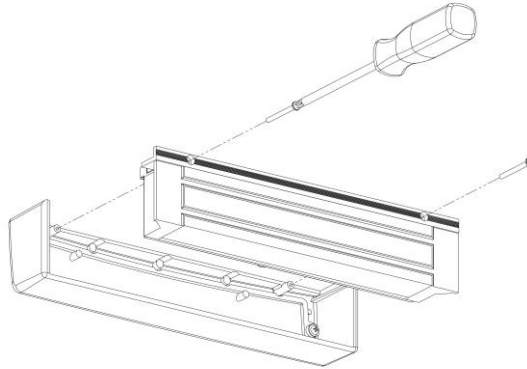



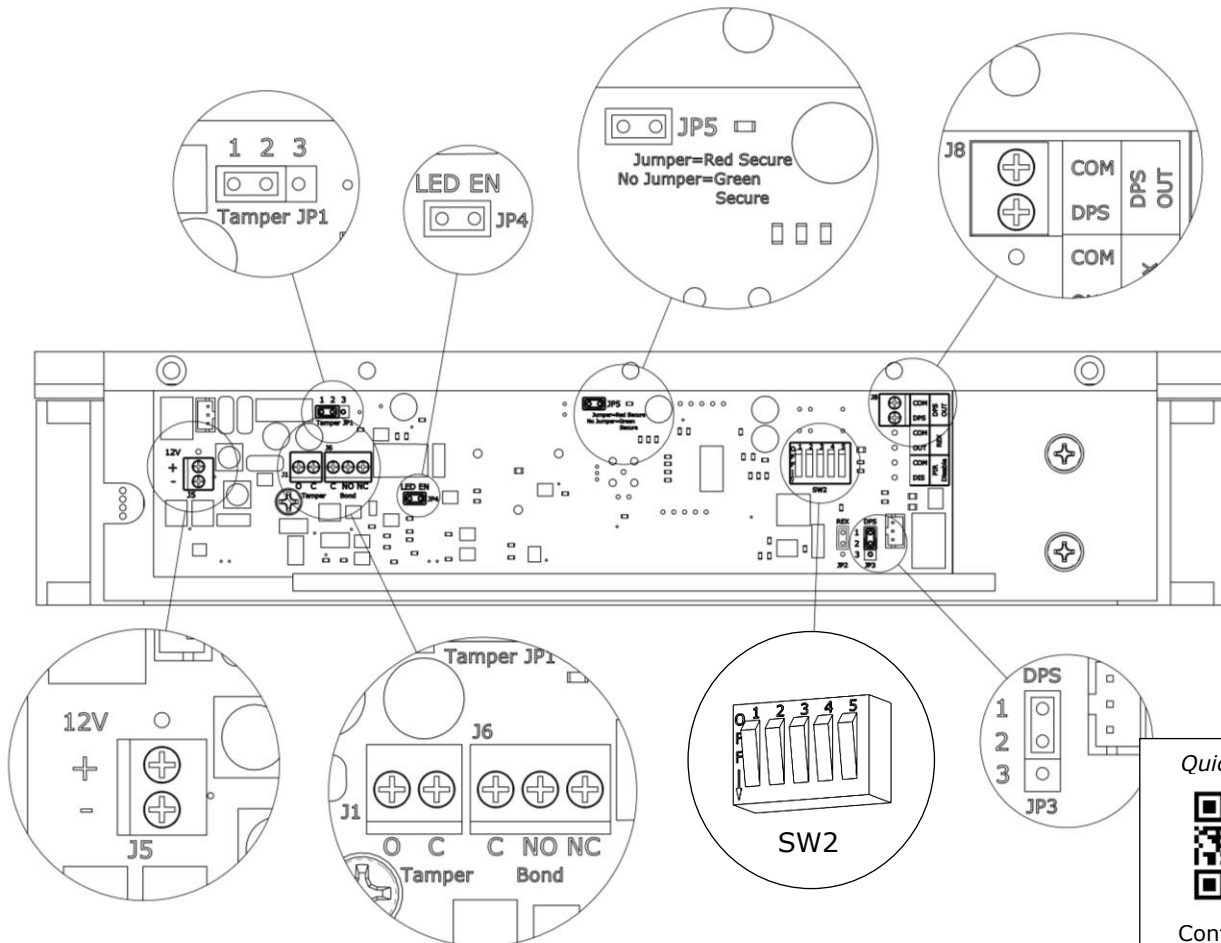





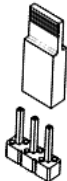

## 2. Component Locations



Quick Clip 1:

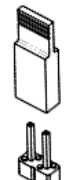

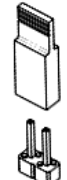
Configuration

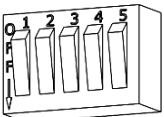
Component Label	Component Name	Selection	Position
<b>JP1</b> 	<b>Jumper 1: Tamper Switch Mode Select</b>  A 3-pin jumper that controls the output setting for Tamper Switch SW1 at Terminal Block J1.	<b>(NC) Normally Closed</b> Circuit Closed when Cover Closed (default setting)	
		<b>(NO) Normally Open</b> Circuit Open when Cover Closed	
<b>JP3</b> (available on M680 models only) 	<b>Jumper 3: Door Position Mode Select</b>  A 3-pin jumper that controls the output setting for the Door Position Switch (DPS) in Terminal Block J8 Position 1 & 2.	<b>(NC) Normally Closed</b> Circuit Closed when Door is Closed (default setting)	
		<b>(NO) Normally Open</b> Circuit Open when Door is Closed	
<b>JP4</b> 	<b>Jumper 4: LED Enable</b>  A 2-pin jumper that enables the LED.	<b>LED ENABLED</b> (default setting)	
		<b>LED DISABLED</b> (jumper removed)	
<b>JP5</b> 	<b>Jumper 5: LED Color Select</b> A 2-pin jumper that controls the color of the LED output. Output options are red or green.	<b>SECURE = RED LED</b> (default setting)	
		<b>SECURE = GREEN LED</b> (jumper removed)	
<b>SW2</b> (available on M680 models only) 	<b>DIP Switch Auto Relock Timer Enable and Delay Selection</b>  The Auto Relock Delay Timer is disabled by default. The delay can be enabled by setting Switch 4 to ON, and then selecting a time delay with Switch 1 and Switch 2.	<b>DISABLE Delay Timer</b>	Switch 4 OFF (default)
		<b>ENABLE Delay Timer</b>	Switch 4 ON
		5 second delay	Switch1 OFF, Switch2 OFF
		10 second delay	Switch1 OFF, Switch2 ON
		20 second delay	Switch1 ON, Switch2 OFF
		30 second delay	Switch1 ON, Switch2 ON

<b>J1</b>	<b>Terminal Block 1 Tamper Switch</b>	A 2-wire terminal block providing a SPDT contact that changes state as determined by JP1 when the cover is sensed to be removed by SW1.
<b>J5</b>	<b>Terminal Block 5 Input Power</b>	A 2-wire terminal block providing connection to the power supply. Position 1 is (+). Position 2 is (-).
<b>J6</b> (available on M680 models only)	<b>Terminal Block 6 BondSTAT</b>	A 3-wire terminal block providing a SPDT 1-Form C contact that changes state when the BondSTAT bond is interrupted.
<b>J8</b> (available on M680 models only)	<b>Terminal Block 8 Door Position Switch</b>	A 2 wire terminal block providing 1 SPST contact that state change is determined by Jumper 3 based on the magnet's contact with the strike plate. (Available on M680 only)

### 3. Document Configuration Settings

The Board Settings are now complete. Copy your settings onto the adhesive-backed Circuit Board Settings label enclosed with the mounting hardware packet.

<b>M670/M680 Settings</b>		<a href="http://www.securitron.com">www.securitron.com</a>	
Jumper 4 (JP4) LED Enable	<u>ENABLED</u>	DISABLED	
Jumper 5 (JP5) LED SECURE Color	<u>RED</u>	GREEN	
*Jumper 1 (JP1) Tamper Select Mode	<u>NC 1-2</u>	NO 2-3	
*Jumper 2 (JP2) Request to Exit Mode	NO 1-2	NC 2-3	
*Jumper 3 (JP3) Door Position Mode	<u>NC 1-2</u>	NO 2-3	
*(SW2) Auto Relock Delay	ENABLED	<u>DISABLED</u>	
*Delay (in seconds)	0 5 10 20 30		
*available on select models		<b>1-800-MAGLOCK</b>	

**Note:** The example shows the Default settings. Your settings may vary, based on your checklist.

**NO = Normally Open**  
**NC = Normally Closed**

#### Important! Complete the label and affix to the inside cover of your Magalock

This information will be needed if the lock needs to be serviced, replaced or inspected.

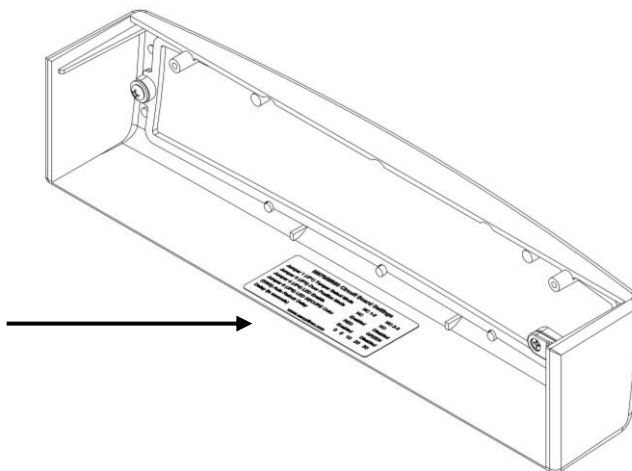

# Magnalock Installation

**1.** Remove three (3) screws securing lock to mounting bracket and slide the bracket from the top of the lock chassis.

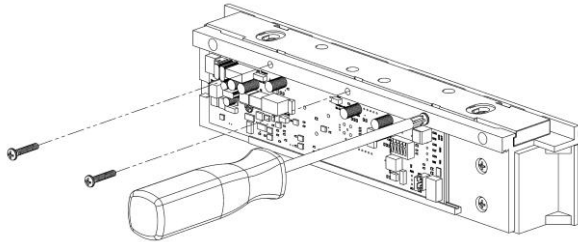

**2.** Pinch and insert spacers flush into the dovetail slots of the lock-mounting bracket.

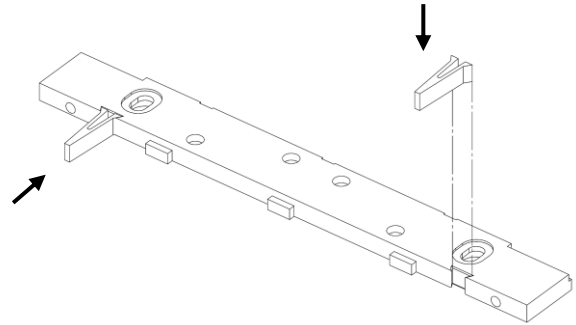

## 3. Mark Mounting Holes:

Use masking tape to protect the door and frame surfaces during marking and drilling. Place the lock bracket on the secure side of the door against the frame stop toward the side of the door that does not have hinges. Close the door and adjust the bracket so that the spacers rest against the door. Mark the frame through the two (2) oblong bracket mounting holes.

**Note:** Maintain 7/8" minimum clearance from the frame

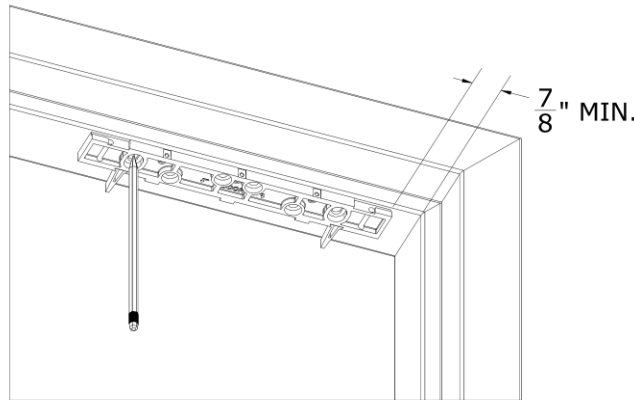

Quick Clip 2:



Mounting the Bracket

## 4. Mark Wire Feed-Through Holes:

Mark the frame for wire feed-through hole at the end closest to where you will access the wire run. These holes should be toward the rear edge of the mounting bracket and be adjacent to the end of the bracket as shown. Remove mounting bracket from frame when drilling holes.

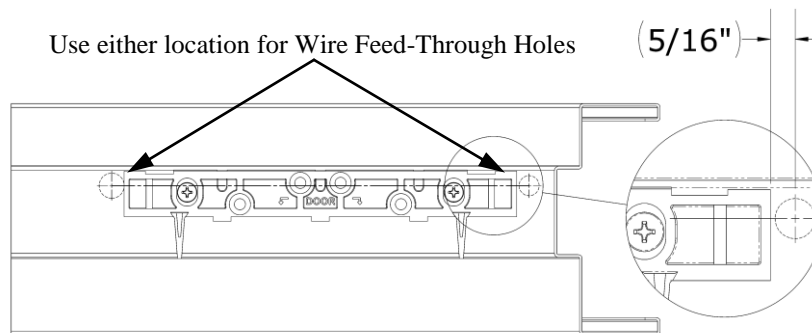

## 5. Metal Door Frame - Drill Mounting Holes:

**Note:** If installing on a wood door frame, go to Step 7.  
Drill two (2) 3/8" diameter holes at bracket-mounting hole marks.

**Note: Do not oversize the hole.  
Use a step bit or pilot hole first to  
ensure a snug fit for the blind nuts.**

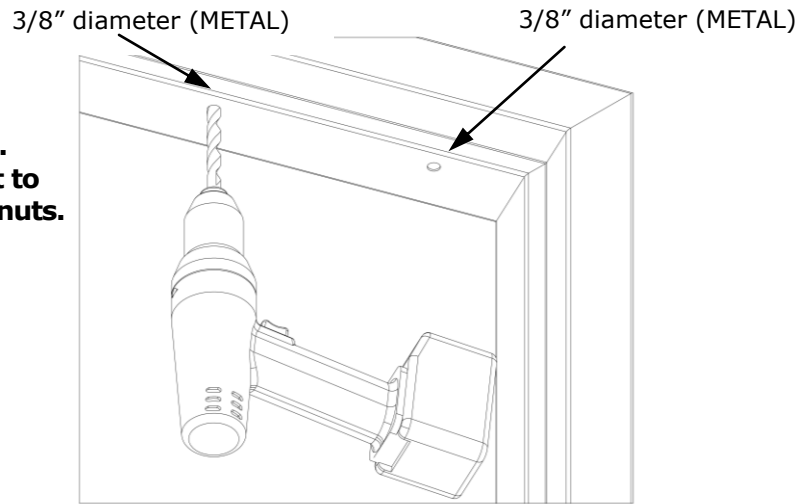

## 6. Blind Nut Installation:

Use the tool provided to install blind nuts into each 3/8" diameter hole. Hold the collapsing nut with a 1/2" box end wrench. Maintain pressure on the mounting surface, while using a 3/16" hex wrench to tighten the cap screw and collapse the blind nut. Go to Step 8.

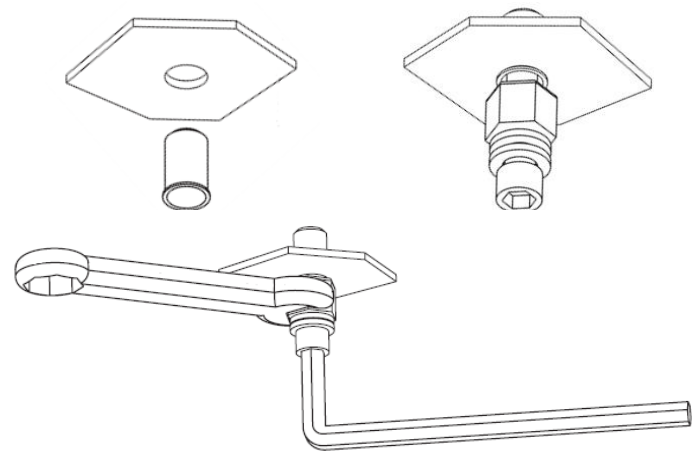
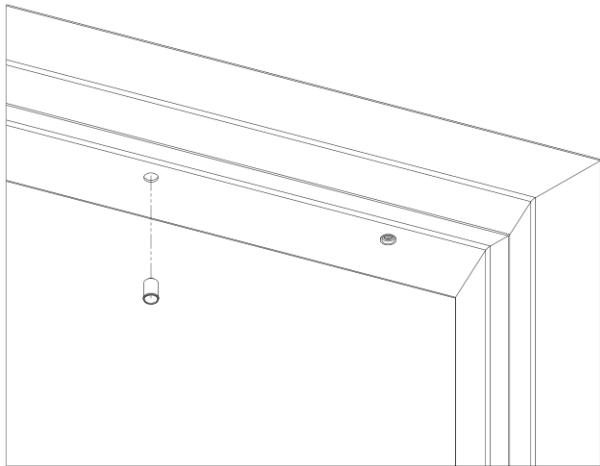

### **Why Use Blind Nuts?**

*Blind nuts provide a highly secure and tamper resistant system for mounting and are the mounting hardware provided for this unit.*

*Only use approved included hardware for mounting.*

Quick Clip 3:



Blind Nut  
Installation

## 7. Wood Door Frame – Drill Mounting Holes:

Drill two (2) 3/16" diameter holes at bracket-mounting hole marks.  
Drill 1 1/4" deep.

3/16" diameter (WOOD)

3/16" diameter (WOOD)

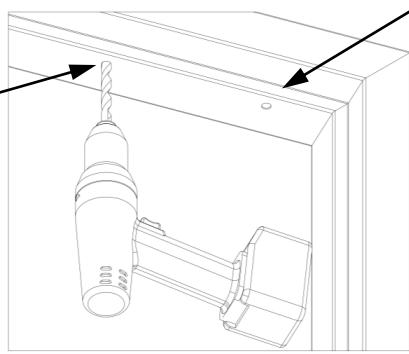

## 8. Drill Wire Access Holes

Drill wire access holes as needed on one (1) or both sides of the bracket location.  
1/2" diameter is recommended for wire access.

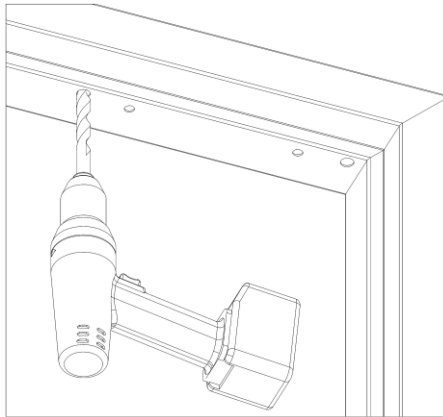

## 9. Install Bracket:

Use a Phillips screwdriver to temporarily install the bracket with spacers against the closed door.

**Metal Frames:** Use two (2) 1/4-20 X 1" Phillips Pan Head Screws and apply included thread lock to screw threads

**Wood Frames:** Use two (2) #12 X 1-1/2" Type A, Phillips Pan Head Screws.

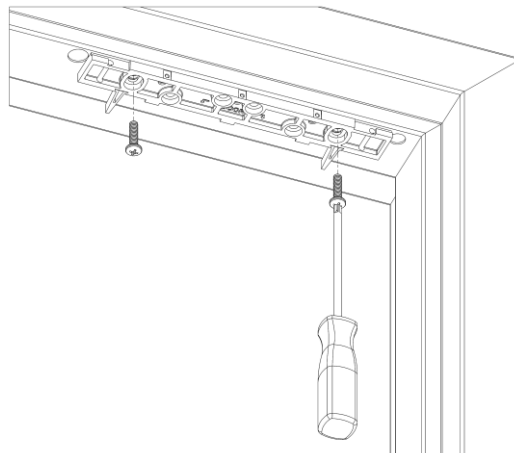



# Strike Installation

- 1.** Close the door and place the template between the bracket spacers. Mark the strike plate hole locations. Bracket spacers can now be removed from the bracket.

Quick Clip 4:



Strike Installation

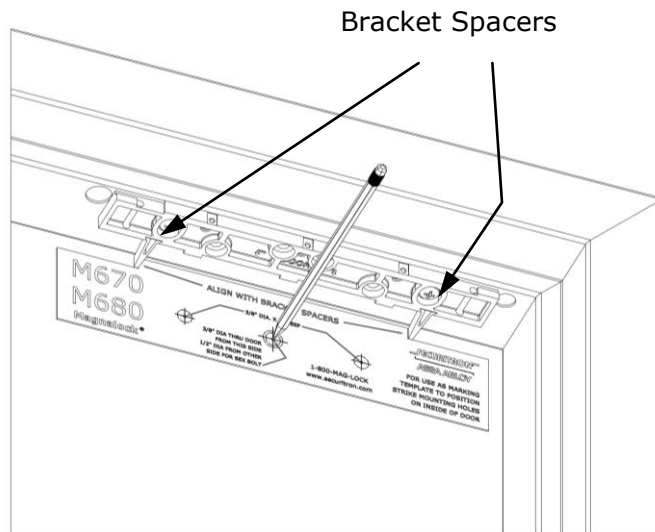

**2. From INSIDE the door:**

Drill **one (1) 3/8" diameter hole** for the sex bolt **through** the door at the strike mounting center mark.  
Drill **two (2) 3/8" diameter x 1" deep holes** at each side mark for the strike alignment roll pins. **Do not drill through the door.**

Quick Clip 5:



Door Drilling

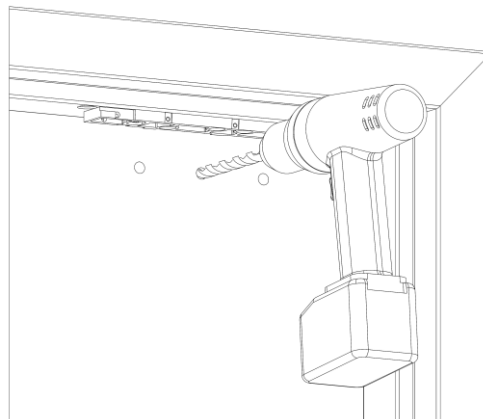

**3. From OUTSIDE the door:**

For a **Hollow Metal Door**: Drill out the 3/8" diameter strike mounting hole to 1/2" diameter in the **outer wall only**.  
For a **Solid Wood Door**: Drill out 3/8" diameter strike mounting hole to 1/2" diameter; **drill completely through**.

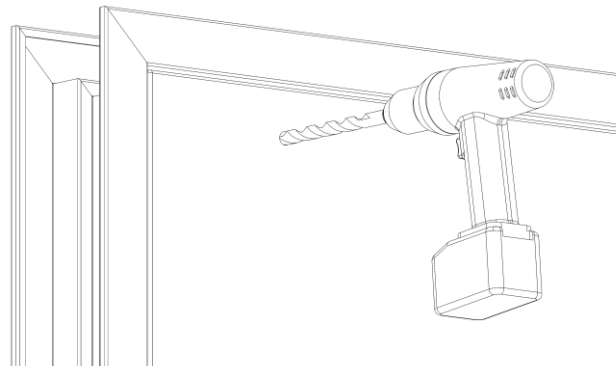

#### 4. Install Roll Pins into Strike Plate:

Remove the two (2) roll pins from the hardware packet.  
Insert a roll pin into each of the holes in back of strike. Gently tap into place using a hammer.

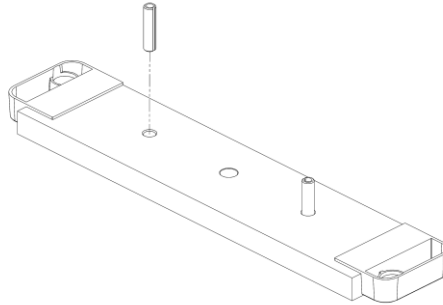

#### 5. Secure Strike Plate to the Door

Apply the included threadlock compound to the 5/16-18 X 1-3/4" flat head socket screw.  
Pass the 5/16-18 X 1-3/4" flat head socket screw through the strike plate, two (2) neoprene washers, door and into the sexbolt as illustrated.

Use a 3/16" hex wrench to tighten the screw into the sex bolt. (While tightening, use a hammer to gently tap the head of the sex bolt until the head sits flush with the door).

**Do NOT over-tighten the assembly, the neoprene washers should not be compressed.**

Allow the strike to rock on the neoprene washers for proper function and optimum holding force.

Quick Clip 6:



Mounting  
Strike Plate

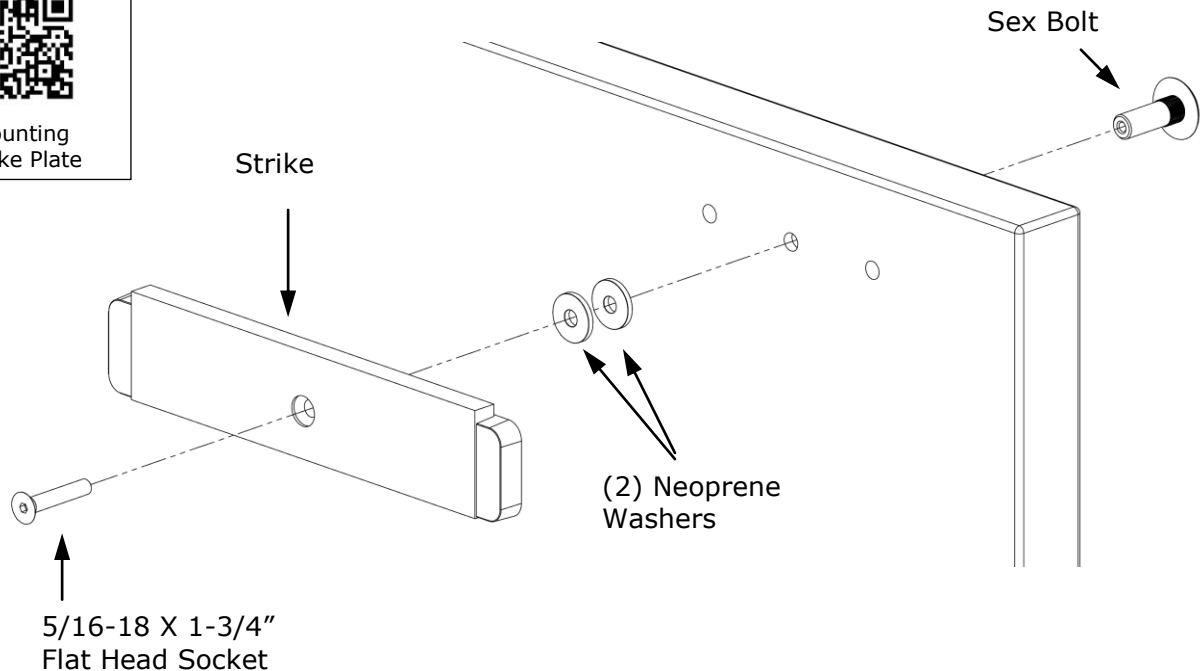

## Adjustments:

### 1. Assemble Lock to the Bracket and Adjust:

Loosen the two screws securing the mounting bracket to the door frame so that the bracket can move.

Slide the lock onto the mounting bracket and test fit against the strike plate with the door closed. Slide the lock so that the entire face makes contact with the strike plate.

Mark back edge of mounting bracket at each end and remove the lock from the bracket.

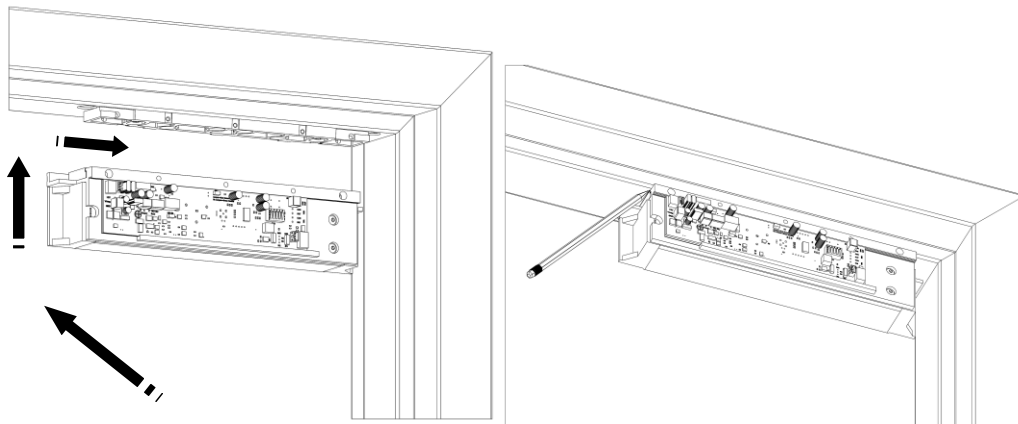

Quick Clip 7:



Adjustment

### 2. Ensure that the mounting bracket aligns with the marks and tighten the mounting screws.

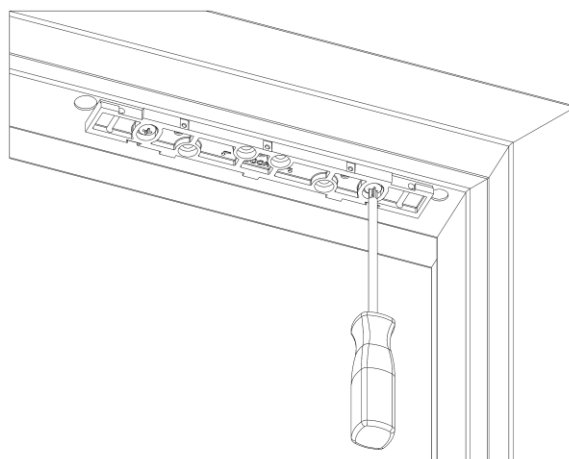

### 3. Drill Frame for Anchor Screws:

Using the mounting bracket as a template, drill the four remaining holes in the frame for the anchor screws.

**Metal Frames:** Drill 3/16" diameter holes.

**Wood Frames:** Drill 7/32" diameter holes.

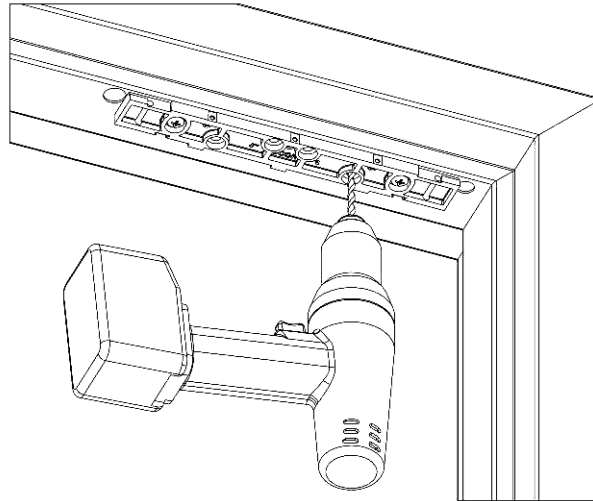

### 4. Install Anchor Screws:

Using a Phillips screwdriver, install the four (4) anchor screws.

**Metal Frames:** Use #12 X 1-1/2" Type A, Phillips Pan Head Screws.

**Wood Frames:** Use #14 X 3" Type A, Pan Head Screws.

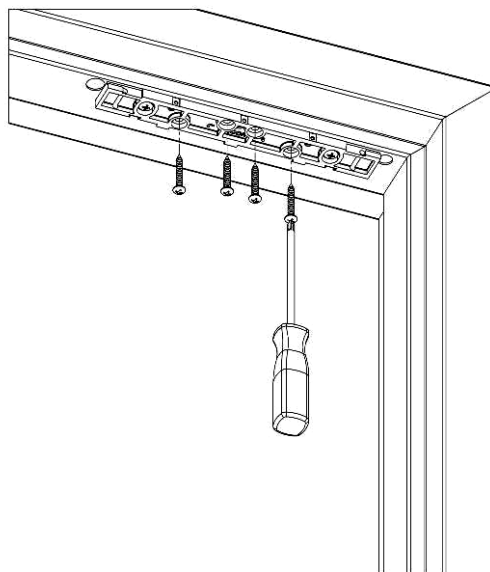

## Final Installation:

1. Insert the top of the Magnalock chassis at the end of the mounting bracket. Slide the lock chassis to the center of the bracket.

The edge of the lock chassis must be flush with the end of the mounting bracket when centered (see inset).

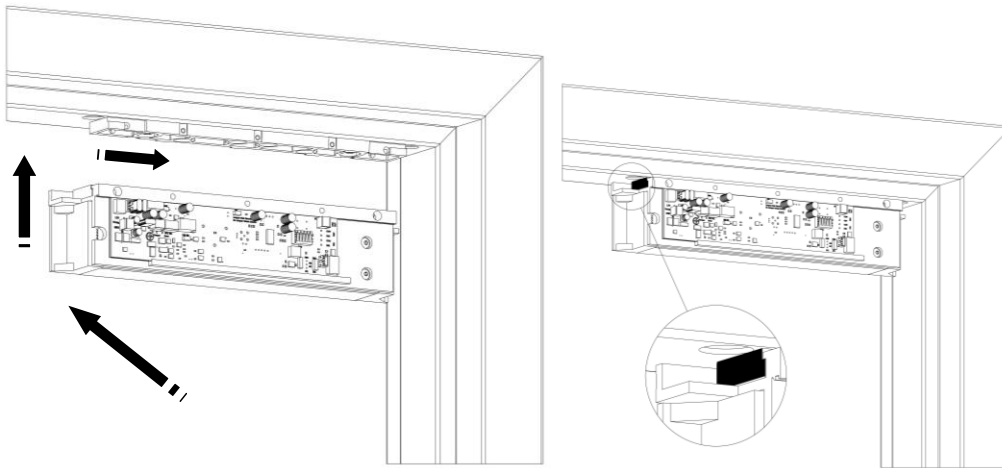

Quick Clip 8:



Final  
Installation

2. Using a Phillips screwdriver, install the three (3) 6-32 X 3/4" Phillips pan head screws to secure the lock chassis to the mounting bracket.

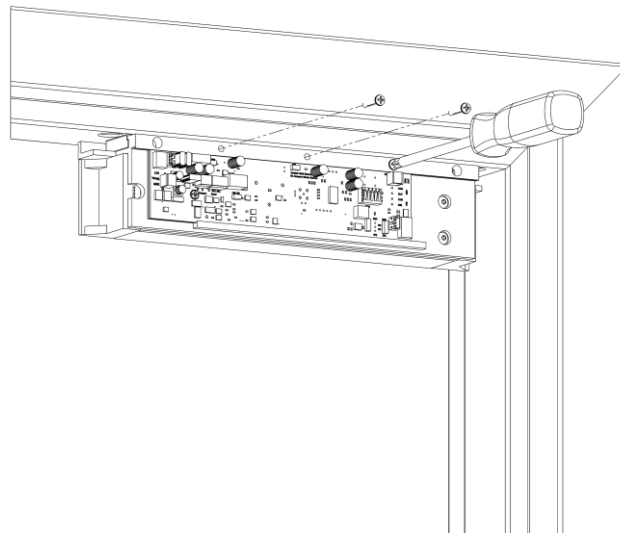

# Final Wiring

1. Pull wires/cables through the wire feed-through hole(s) that are drilled in the frame. A small screwdriver has been included to help make connections to the terminal blocks as required.  
***The end user and installer are liable for Fire and Building code compliance.***

2. The following diagrams show basic wiring configurations for the Magnalock.

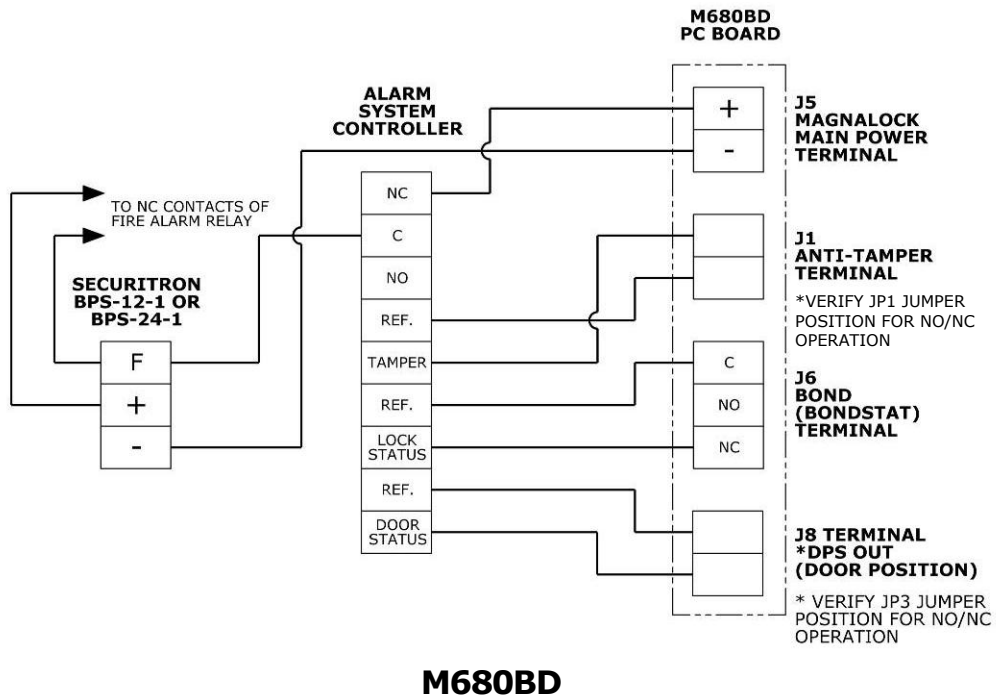
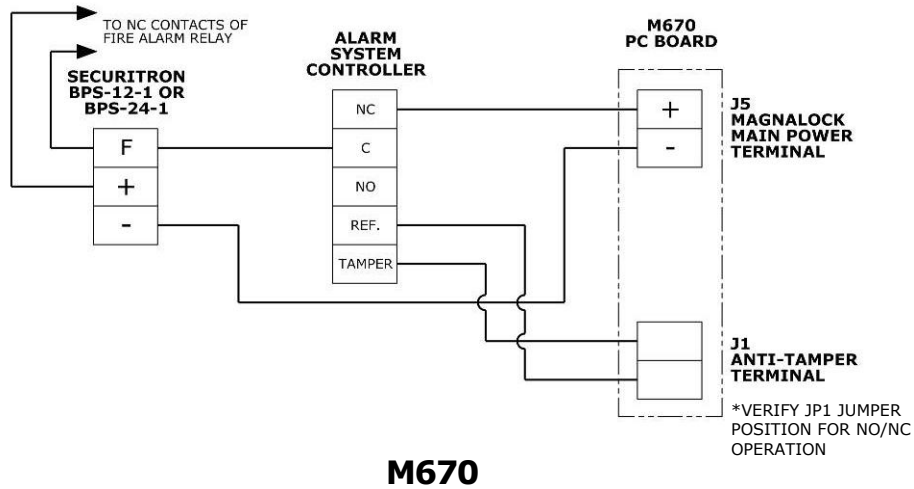

- 3.** After installation and wiring have been completed, re-install the lock cover through the lock chassis using the two (2) phillips screws removed in the first step.

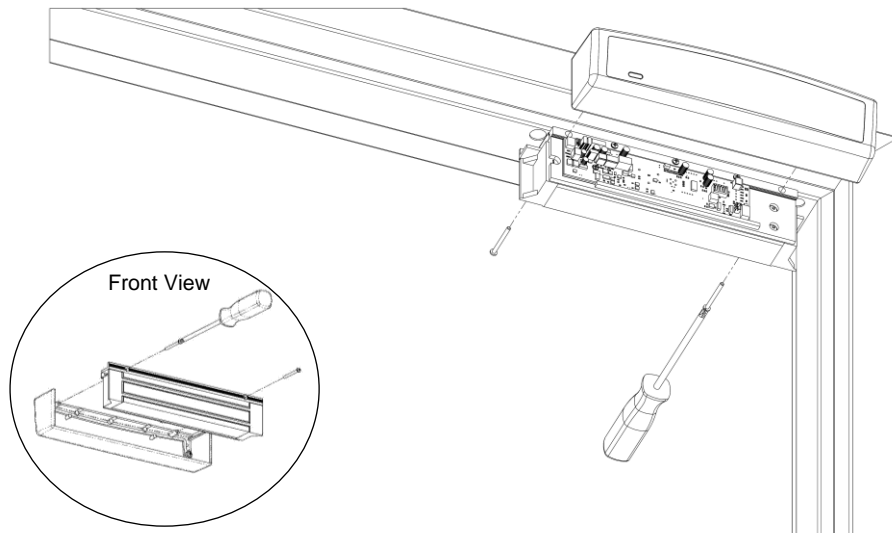

## **MAGNALOCK MAINTENANCE**

### **Visual Inspection**

- Check the rubber washers for elasticity and proper pivoting. Tighten as required.
- Check for build-up of debris on the Magnalock and strike armature.
- Check for rust on the Magnalock and strike plate armature. Clean as required.

### **Cleaning Methods**

- Apply rubbing alcohol onto a clean cloth and thoroughly wipe down the Magnalock and strike plate armature.
- Cleaning once a year is recommended.
- Clean every three to six months where rusting occurs.
- Use a plastic dishwashing scrub pad to aid in the removal of rust.

**DO NOT USE PETROLEUM BASED PRODUCTS FOR CLEANING**

**DO NOT USE STEEL WOOL BASED SCRUB PAD OR SANDPAPER**

## Troubleshooting Guide:

POSSIBLE ISSUES	TROUBLESHOOTING TIPS
No power or low power	Confirm voltage and current at Magnalock to spec (see page 2) Check that the DC Power Source is Full Wave Rectified (Half wave Rectified or AC power is unacceptable)
Reduced Holding Force	Check strike plate position and orientation Clean surfaces and check for obstructions

## LED Error Codes:

Note LED Jumper J4 must be installed (LED ENABLED) for error codes to be visible

CODE	STATE	SOLUTION
SECURE selected color, on continuously	Normal Operation with Door Closed	System working normally, SECURE selected color can be selected with Jumper JP5. See page 4.
NON-SECURE selected color, on continuously	Normal Operation with Door Open	System working normally
RED/GREEN continuous flash	Processor Error	Check all connections, if error persists replace unit
3 Fast Flashes of SECURE color every 5 seconds	Magnet Voltage has dropped below 85%	Check voltage and current at Magnalock connections. Check DC Power Source is Full Wave Rectified.
Single Flash Amber every 5 seconds	Bond Error – Left Side	Check strike plate position and orientation. Clean surfaces and check for obstructions.
Double Flash Amber every 5 seconds	Bond Error – Right Side	Check strike plate position and orientation. Clean surfaces and check for obstructions.
Off	LED disabled	Check voltage and current at Magnalock connections. Check that LED is enabled with a Jumper at JP4

## Problems with Installation?

Call Securitron: **1-800-MAGLOCK**

For warranty information: visit [www.securitron.com/en/site/securitron/About/MagnaCare-Warranty/](http://www.securitron.com/en/site/securitron/About/MagnaCare-Warranty/)