

1-Fijar placas RX - Tx
 2-Fijar tamper(Termostato=opción)
 3-Insertar "reuerzo base." en soporte (calefactor=opción)
 4-Insertar perfil con Rx-Tx en soporte y en refuerzo base
 5-Fijar a pared, insertando cable en tapa inferior + conexiones electricas
 a)llegada cable desde pared
 b)llegada cable exterior

1-Fix Rx or Tx to the aluminium
 2-Fix Tamper(thermostat=option)
 3-Insert reinforcement in the support (Heater as an option)
 4-Insert profile with Rx or Tx in the support and reinforcement
 5-Fix to the wall, insert alarm + electric wire on the bottom cap
 a)If the wire comes from the wall
 b)If the wire comes from other side

1-Fixer plaque posterieur Rx-Tx
 2-Fixer tamper(thermostat=option)
 3-Insérer renforcement dans support (chauffer=option)
 4-Insérer profil avec Rx-Tx dans support et renforcement
 5-Fixer au mur, en insérant câble dans couvercle inf.+connexions électriques
 a)si le câble arrive mural
 b)si le câble arrive ailleurs

1-Fissare placca posteriore Rx-Tx
 2-Fissare tamper(termostato=opzione)
 3-Insere rinforzo nel braccio (riscaldatore = opzione)
 4-Insere profilo con Rx-Tx nel braccio e nel rinforzo
 5-Fissare a parete inserendo cavi nel coperchio inferiore+cablaggio:
 a)se il cavo arriva da parete
 b)se il cavo arriva da fuori

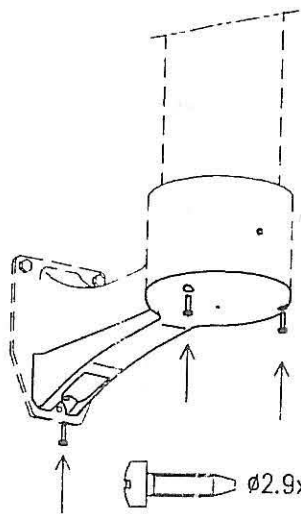

6a

6b

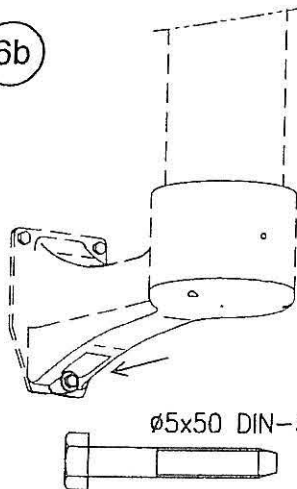

Ø2.9x16 DIN 7981

Ø5x50 DIN-571

7

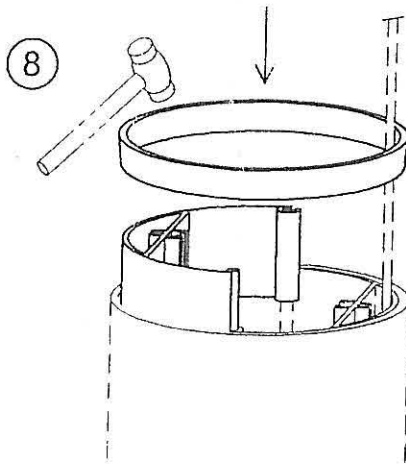
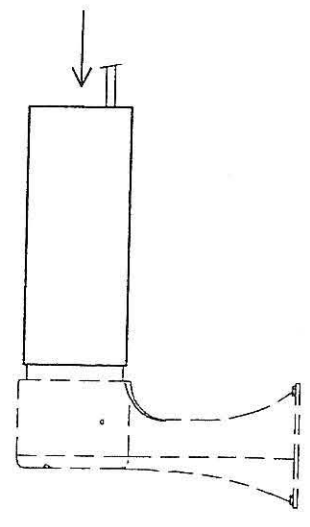

8

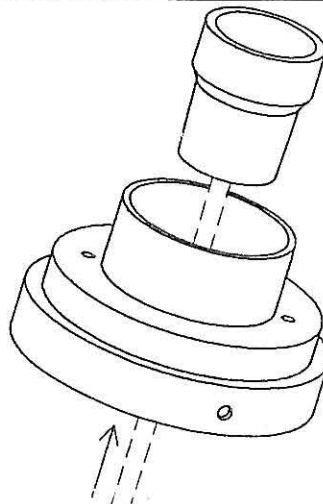

9

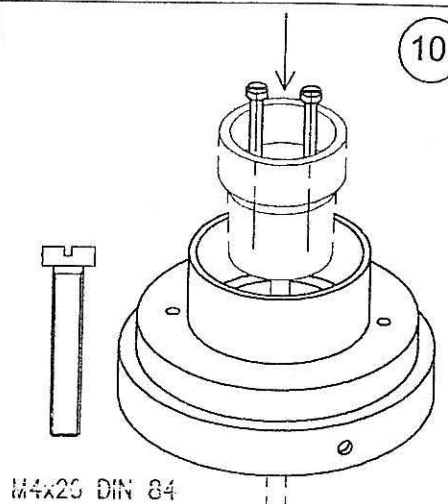

10

M4x20 DIN 84

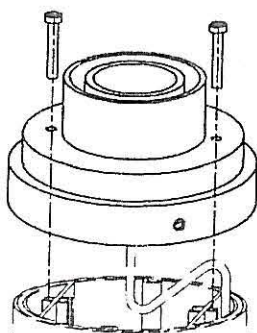

11

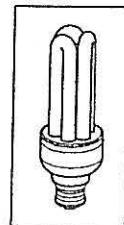

12

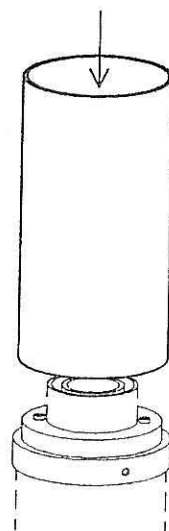

M4x25 DIN 7985

Ø4 DIN 125

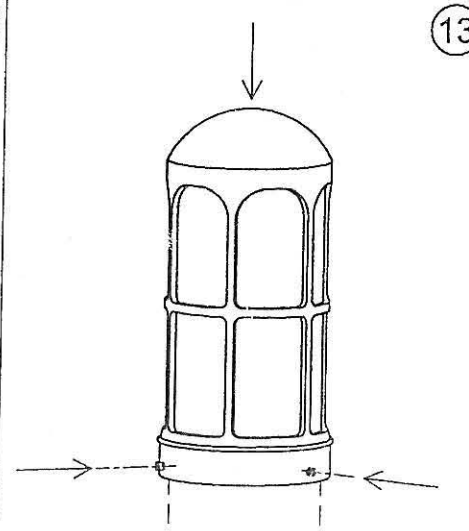
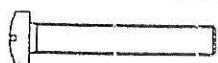

13

M5x12 DIN 914

6-Fijar tapa interior a soporte
7-Insertar tubo policarbonato
8-Insertar anillo y refuerzo cuello
9-Conexionar el casquillo haciendo pasar el cable por el cuello
10-Fijar casquillo en el cuello
11-Fijar el cuello en perfil y "refuerzo cuello"
12-Insertar tubo PC blanco
13-Insertar tapa y fijarla al cuello

6-Fix the bottom cap to the support
7-Insert the black PC tube
8-Insert ring + neck reinforcement
9-Connect the bulb holder. Wire has to go through the neck
10-Fix the bulb holder to the neck
11-Fix the neck to the aluminium reinforcement and Rx-Tx holder
12-Insert the white PC tube
13-Insert the top and fix it to the neck+structure

6-Fixer couvercle inférieur au support
7-Insérer le tube de polycarbonate
8-Insérer bague et renforcement cou
9-Conectter la porte-lampe en faisant passer le câble dans le cou
10-Fixer la porte-lampe dans le cou
11-Fixer le cou dans le profil et le "renforcement cou"
12-Insérer tube PC blanc
13-Insérer caplet et le fixer au cou

6-Fissare coperchio inf. al braccio
7-Insere il tubo nero di PC
8-Insere anello e rinforzo collo
9-Connettere portalampada facendo passare il cavo nel collo
10-Fissare il portalampada nel collo
11-Fissare il collo nel profilo e nel rinforzo collo
12-Insere tubo bianco di PC
13-Insere coperchio superiore e fissarlo al collo