

Package Contents

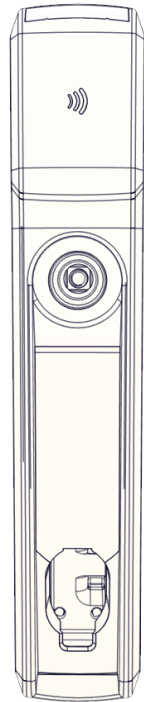

Lock

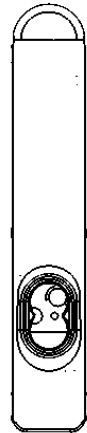

Handle

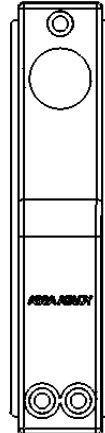

Mounting
Plate



Mounting Screws



Cam



SFIC
Cam



Handling
Selector

DPS Cable

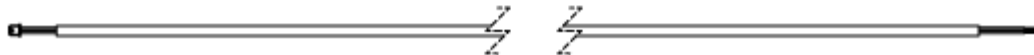

24VDC Cable

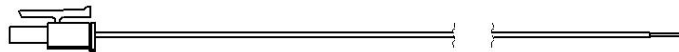

Recommended Tools

Approved RFID Credential
Phillips P2 driver, RJ45 cable
PoE power injector (48VDC)

Optional Additional Tools:
Gang box to mount hub
SFIC Core for key override

Optional Additional Tools:
Normally Open DPS switches

Product Specifications

Wireless Frequency: 2.4 GHz, IEEE 802.15.4, using AES 128bit encryption

Hub Power Requirement: 8-24VDC, 250mA

Lock Power: 48VDC Power over Ethernet (PoE) 802.3af compliant <OR> 24VDC Power Supply (Supply not provided)

Power Consumption: Less than 1W

Operating Temperature: -10C to 50C

Holding Force: 250 lbs

FCC Part 15, Compliant, Industry Canada Compliant

BHMA: A156.3, A156.36, A156.25 Compliant

Credentials Supported: 125kHz Proximity or 13.56MHz iCLASS, iCLASS SEOS, iCLASS SE, ISO1443B UID, Mifare, Mifare Plus, Desfire SE, Desfire EV1, and NFC credentials are supported depending on lock model.

For technical support please call 1-800-626-7590

System Overview

The KS100-640 wireless server cabinet lock extends access control to a server cabinet without the complexity and expense of running wires. The KS100-640 cabinet lock connects to an access control system through the included communication hub. The communication hub connects to the access control system with Wiegand wiring typical of a Wiegand reader.

When a credential card is presented to the reader on the lock, the request for access is sent wirelessly to the communication hub. The communication hub then communicates through Wiegand wiring to the access control system where the decision is made to grant or deny access.

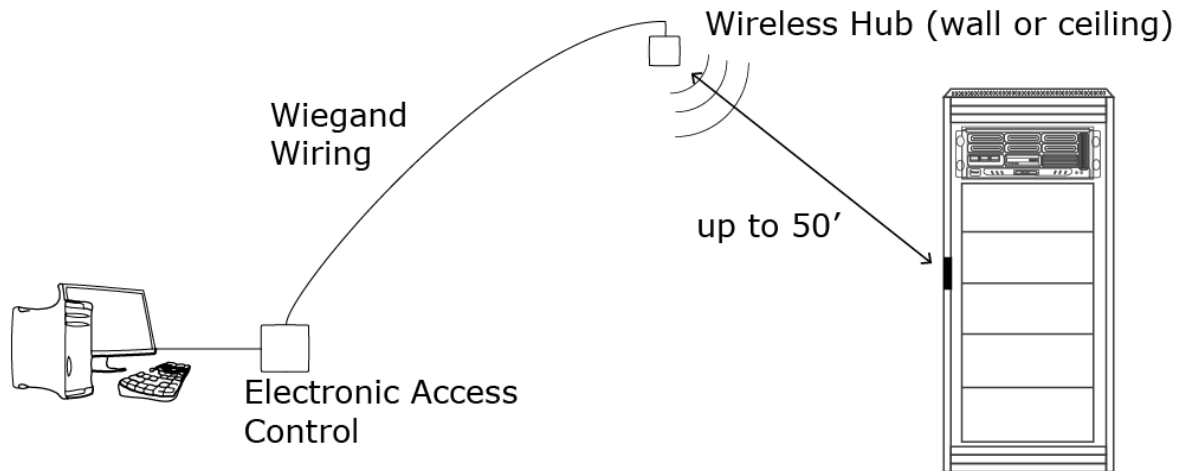

Installation Steps

A. Install an SFIC Core

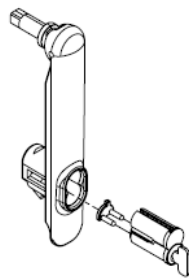

B. Prepare the Cabinet

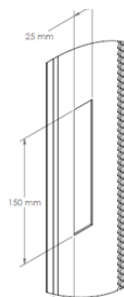

C. Install the Lock

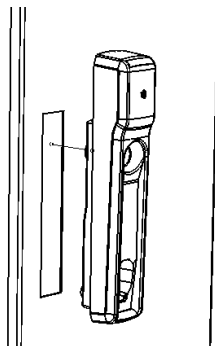

D. Install Handing Selector

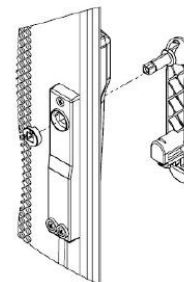

1. Installing an SFIC Core

A key override (SFIC) provides a backup entry method in the rare case the KS100 or access control system is inactive. We recommend this option.

The included SFIC cam has been tested with Medeco and Sargent 6- or 7-pin SFIC cores.

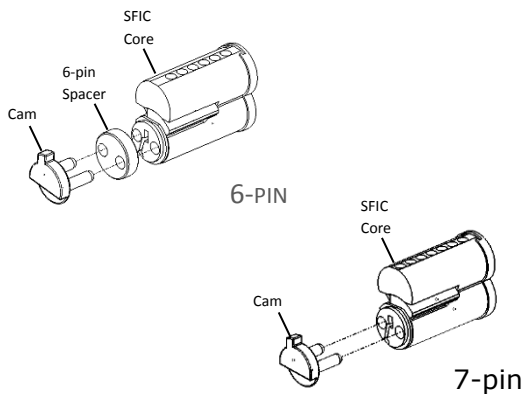

1. Insert Cam into SFIC
Use the included Spacer with 6-pin SFICs.

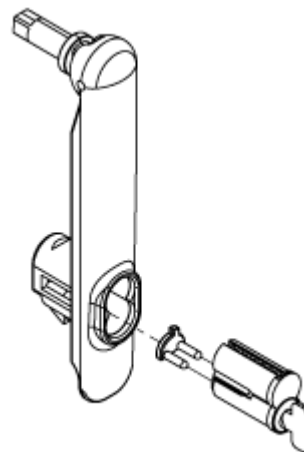

2. Insert SFIC into lock

2. Prepare the Rack

Locate the 25mm x 150mm lock cutout on the door, some doors may require modification.

1. Verify 48V POE power is available at the rack.
2. Re-use the existing cam if possible.
3. One cam is supplied.

CAM	CAM LENGTH	CAM DEPTH
CAM 1	38mm [1-1/2"]	16mm [5/8"]

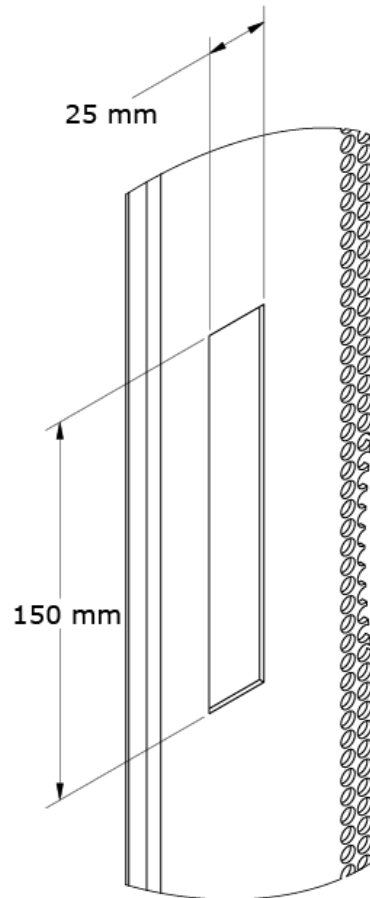
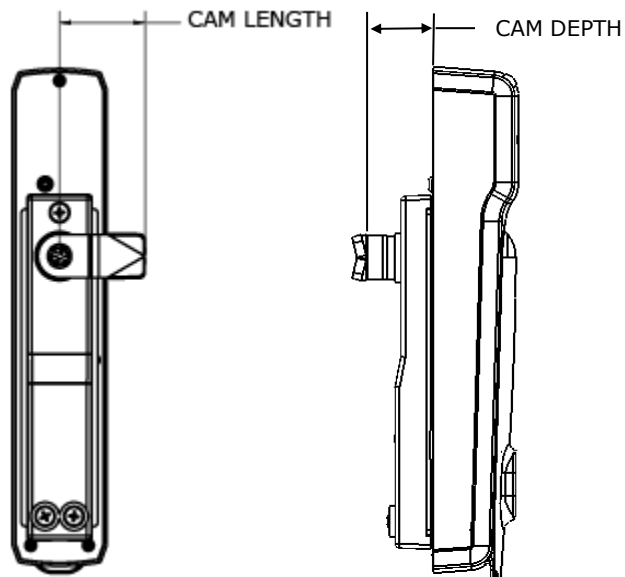

3. Installing the lock on the door

1. Slide lock into cutout.

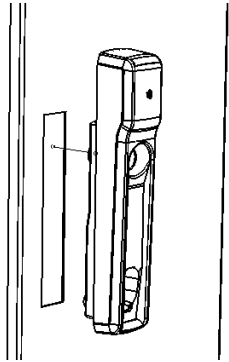

Connect 24VDC cable to lock. Connect 24VDC power supply (not provided) to 24VDC cable.

Red wire (24VDC), black wire (Ground)

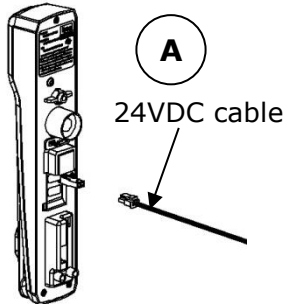

2. Select Power source:

(A. 24VDC Supply <OR> B. 48V PoE)

B
Plug 48V PoE RJ-45 cable into lock. Lock will beep once and perform self test.

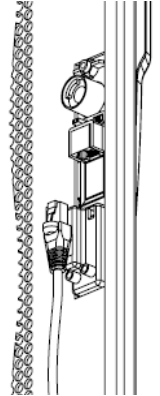

3. Optional: The DPS signal is closed when the handle is resting in its locked position. The DPS circuit can be extended to include normally open DPS switches arranged in a series to monitor additional doors and panels.

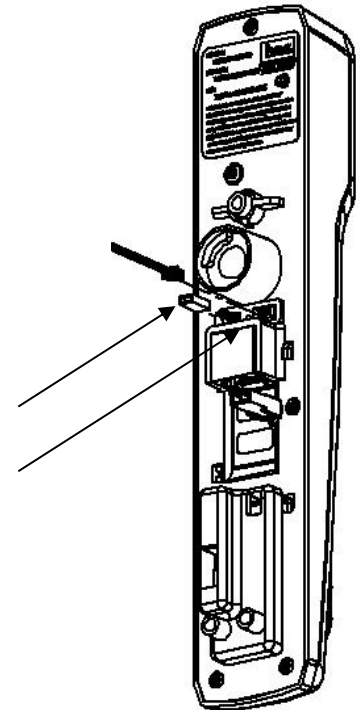
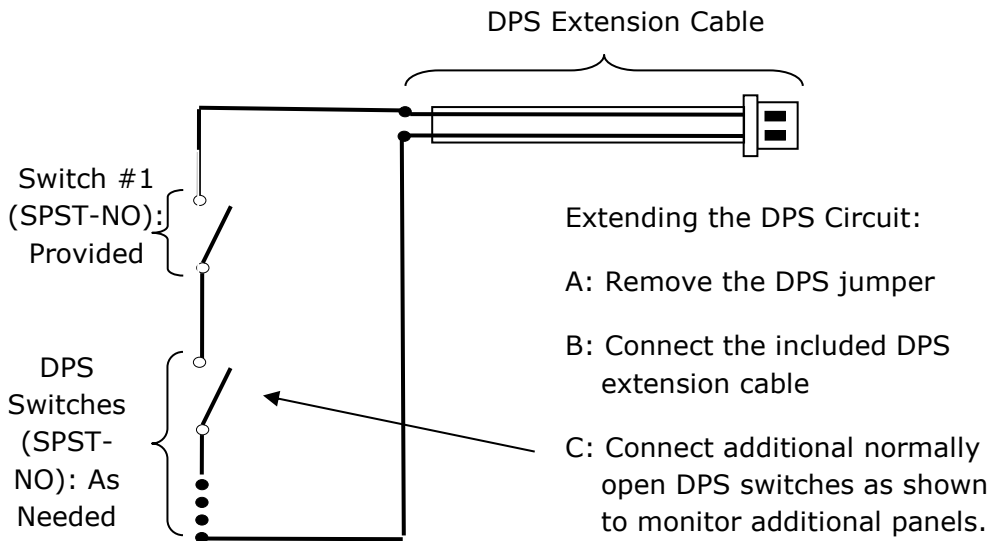

4. Attach rear bracket with screws.

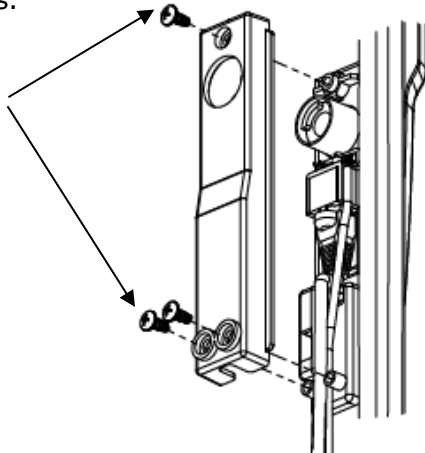

5. Ensure that the lock is fully secured and flush to the mounting surface in order to depress tamper switch on back of device for correct operation.

Tamper Switch

NOTE: If the tamper switch is not fully depressed, you will see a flashing red light and the device will not read cards.

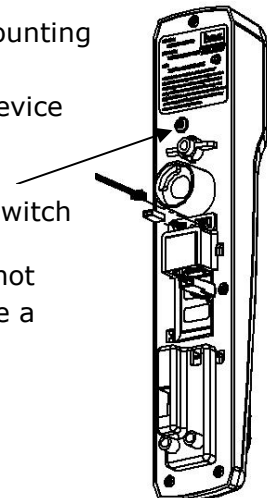

4. Installing the Handing Selector

Note: Be careful not to insert/snap the handle all the way in as the lever will lock.

1. Insert handing selector into lock.

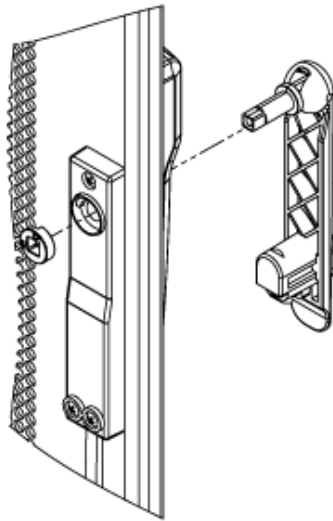

Door edge

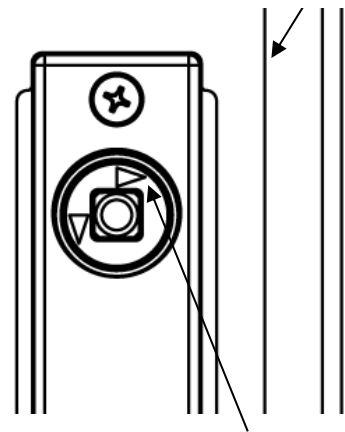

2. Position the arrows to point toward the door edge as shown above.

3. Secure cam with screw.

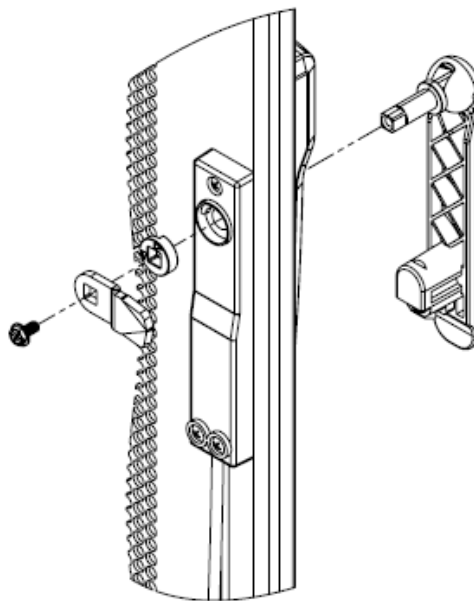

This page intentionally left blank

This page intentionally left blank

WARNING

FCC Statement

This equipment has been tested and found to comply with the limits for a class B digital device, pursuant to part 15 of the FCC Rules. These limits are designed to provide reasonable protection against harmful interference in a residential installation. This equipment generates, uses, and can radiate radio frequency energy and if not installed and used in accordance with the instructions, may cause harmful interference to radio communications. However, there is no guarantee that interference will not occur in a particular installation. If this equipment does cause harmful interference to radio or television reception, which can be determined by turning the equipment off and on, the user is encouraged to try to correct the interference by one or more of the following measures:

- Reorient or relocate the receiving antenna.
- Increase the separation between the equipment and receiver.
- Connect the equipment into an outlet on a circuit different from that to which the receiver is connected.
- Consult the dealer or an experienced radio/TV technician for help.

Operation with non-approved equipment is likely to result in interference to radio and TV reception. The user is cautioned that changes and modifications made to the equipment without the approval of manufacturer could void the user's authority to operate this equipment.

IC Statement

This device complies with Industry Canada license-exempt RSS standards(s).
Operation is subject to the following two conditions:

- (1) this device may not cause interference, and
- (2) this device must accept any interference, including interference that may cause undesired operation.

Conformité aux normes FCC

Cet équipement a été testé et trouvé conforme aux limites pour un dispositif numérique de classe B, conformément à la Partie 15 des règlements de la FCC. Ces limites sont conçues pour fournir une protection raisonnable contre les interférences nuisibles dans une installation résidentielle. Cet équipement génère, utilise et peut émettre des fréquences radio et, s'il n'est pas installé et utilisé conformément ment aux instructions du fabricant, peut causer des interférences nuisibles aux communications radio. Rien ne garantit cependant que l'interférence ne se produira pas dans une installation particulière. Si cet équipement provoque des interférences nuisibles à la réception radio ou de télévision, qui peut être déterminé en comparant et en l'éteignant, l'utilisateur est encouragé à essayer de corriger les interférence par une ou plusieurs des mesures suivantes:

- Réorienter ou déplacer l'antenne de réception.
- Augmenter la distance entre l'équipement et le récepteur.
- Branchez l'appareil dans une prise sur un circuit différent de celui auquel le récepteur est connecté.
- Consultez votre revendeur ou un technicien radio / TV pour assistance. Avertissement

Les changements ou modifications à cet appareil sans expressément approuvée par la partie responsable de conformité pourraient annuler l'autorité de l'utilisateur de faire fonctionner cet équipement.

Conformité aux normes IC

Cet appareil est conforme avec Industrie Canada exempt de licence RSS standard(s).
Son fonctionnement est souimes aux deux conditions suivantes:

- (1) cet appareil ne peut causer d'interférences, et
- (2) cet appareil doit accepter toute interference, y compris des interférences qui peuvent provoquer un fonctionnement indésirable du périphérique.

For Technical Support please call 1-800-626-7590