

**Integrated Movement Exit Delay  
System with Advanced Technology  
Models iMXDa and iEXDa  
Installation Instructions and User's Guide**

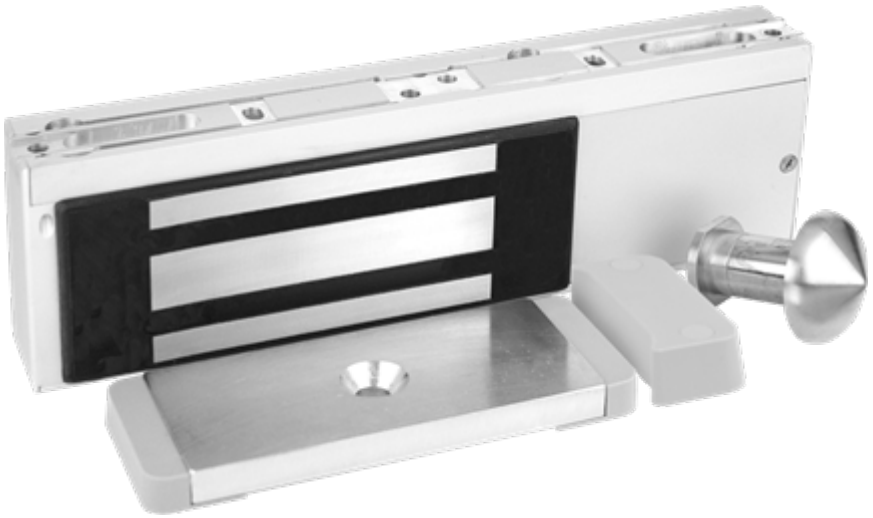

# TABLE OF CONTENTS

TABLE OF CONTENTS .....	2
WARRANTY .....	4
INTRODUCTION .....	5
SPECIFICATIONS .....	5
PRODUCT OVERVIEW .....	6
RECOMMENDED TOOLS .....	6
INSTALLATION .....	7
Performing a Pre-Installation Survey .....	7
Configuring the Mounting .....	7
Mounting the Strike .....	8
Mounting the Actuator .....	10
Mounting the Lock Housing .....	10
Installing the Blind Nuts .....	12
Replacing the Mortise Cylinder and Cam .....	13
General .....	13
Alternate Cylinders .....	13
Alternate Cams .....	13
Installing the Electrical Connections .....	14
General Characteristics .....	14
Electrical Standards .....	14
Sensor Ranges (Electrical) .....	14
Electrical Wiring .....	15
Power Supply Connections .....	15
Emergency Release .....	17
SYSTEM OPERATIONS .....	17
General Operations Description .....	17
Component Layout .....	18

Power On Reset .....	18
Integrated Reset/Bypass (IRB) Key Switch.....	18
Standard Operational Mode .....	18
Bypass Mode — IRB (or External) .....	19
Reset — IRB (or External).....	19
System Functions .....	19
General.....	19
Nuisance Delay Alarm (NDA) — DIP Switches SW1 and SW2 .....	21
Irrevocable Alarm (IRA) — DIP Switch SW3.....	21
Bypass Delay Time (BDT) — DIP Switches SW4 and SW5.....	21
Post Alarm Reminder (PAR) — DIP Switch SW6.....	22
Bypass Expiration Alarm (BEA) — DIP Switch SW7.....	22
Manual/Delayed Relock (MDR) — DIP Switch SW8.....	22
Alarms .....	22
Internal (Local) Alarm .....	22
External (Remote) Alarm.....	22
Control Wiring.....	22
Wiring Layout .....	22
External Controls.....	25
External Initiate (iEXDa).....	25
Tamper Status (JP1) and Door Status (JP2) wiring .....	25
Wire Gauge and Length .....	25
General.....	25
Determining Wire Gauge and Length .....	26
Adjusting the Gap (iMXDa only) .....	27
Installing the EXD-1L Label .....	28
Specialized Mounting Brackets .....	28
Operational Information .....	28
State of California – iMXDa-CA .....	28

City of Chicago – iMXDa-CH .....29  
MAGNALOCK MAINTENANCE .....30  
    Performing an Inspection .....30  
    Cleaning the Magnalock .....30  
TROUBLESHOOTING .....30

## **WARRANTY**

The iMXDa and iEXDa are covered by the MagnaCare® lifetime replacement no fault warranty. No registration is required. Product will be replaced forever, for any reason, including but not limited to installation error, vandalism, or act of God. Replacement product is shipped at Securitron’s expense next day air if needed.

For more information, visit [www.securitron.com](http://www.securitron.com)

# INTRODUCTION

The Securitron iMXDa is an integrated system incorporating Magnalock® reliability with all-in-one exit delay. This system incorporates Securitron's BondSTAT and DPS [Door Position Sensor] technology along with intelligent microprocessor-based, alarm options and a trainable door movement feature. The unit features auto-sensing dual voltage (12 VDC or 24 VDC) and provides a variety of selectable operating functions. The iEXDa is an externally triggered exit delay unit that requires no movement and can be used with Securitron's Touch Sense Bar series of electronic exit bars as well as other manufacturer's mechanical exit bars equipped with Request to Exit (REX) switches. The iEXDa includes all of the improvements found on the iMXDa.

Securitron also offer a City of Chicago- and State of California-compliant versions.

This manual is intended to provide the installation/mounting configurations, electrical requirements, functional options, and selectable settings required to successfully install an iMXDa or iEXDa integrated movement exit delay door system.

**IMPORTANT: This product must be installed according to all applicable building and life safety codes!**

# SPECIFICATIONS

<b>Holding Force</b>	1200 Lbs [544 kg]
<b>Dimensions:</b>	Length 12.5" [318 mm] Height 3.63 [92 mm] Depth 2" [51 mm]
<b>Dual Voltage:</b>	12 VDC/24 VDC
<b>Current Draw:</b>	370 mA at 12 VDC; 270 mA at 24 VDC
<b>Capacitance:</b>	32 mF at both 12 VDC and 24 VDC.
<b>Door Movement (Gap)</b>	1/8" [3.2 mm] to 1" [25.4 mm]
<b>Sensing Range</b>	
<b>External Alarm Rating</b>	Voltage: 30 VDC (Maximum); Current: 1 Amp (Maximum)

<b>DPS Rating</b>	Voltage: 30 VDC (Maximum); Current: 125 mA (Maximum)
<b>Tamper (TS) Rating</b>	Voltage: 30 VDC (Maximum); Current: 2 Amps (Maximum)
<b>Piezo Sounder:</b>	≥ 85 dB at 12"
<b>Shipping Weight</b>	15 pounds

## PRODUCT OVERVIEW

Along with the installation and operating instruction manual, the quick start guide, and the mounting templates, the product package should include the following:

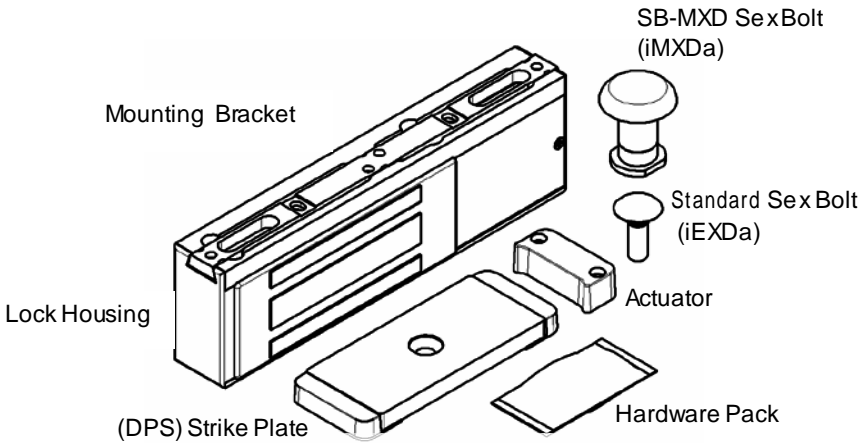

**Figure 1. Product Overview**

## RECOMMENDED TOOLS

The following are the recommended tools for installation:

- Hammer
- Center Punch
- Power Drill
- Drill Bits: 9/64", 3/16", 7/32", 3/8", 1/2" (iEXDa), and 1" (iMXDa)
- Wrenches:
  - 7/16" open end or adjustable
  - 1/2" box/open end or adjustable
  - 1-1/4" open end or 12" adjustable
  - 3/16" hex key (Allen)
  - 3/32" hex key (Allen)
- Pliers, vise grip
- Screwdrivers:
  - #1, #2, and #3 Phillips
  - 1/8" flat blade

- Masking Tape
- Fish Tape or Lead Wire
- Wire Strippers/Cutter
- Multimeter

## INSTALLATION

### Performing a Pre-Installation Survey

1. PERFORM a pre-installation survey to determine the mounting location based on the following:
  - Physical strength of mounting areas should meet or exceed the holding force of the iMXDa/iEXDa.
  - Lock wiring should be routed for protection from damage due to intrusion or vandalism.
  - Door clearance should be considered to prevent a safety hazard.
  - Alignment between the lock face and strike should be considered for proper operations because of the lock system's internal sensing.
  - Additional brackets for proper installation may need to be added and should be considered.

### Configuring the Mounting

**NOTE 1:** The unit may be mounted horizontally or vertically.

**NOTE 2:** Figure 2, "Typical Section of Installation (iMXDa)," provides illustration for the following step.

1. VERIFY that the lock housing will be mounted to the header near the corner opposite the door hinge side

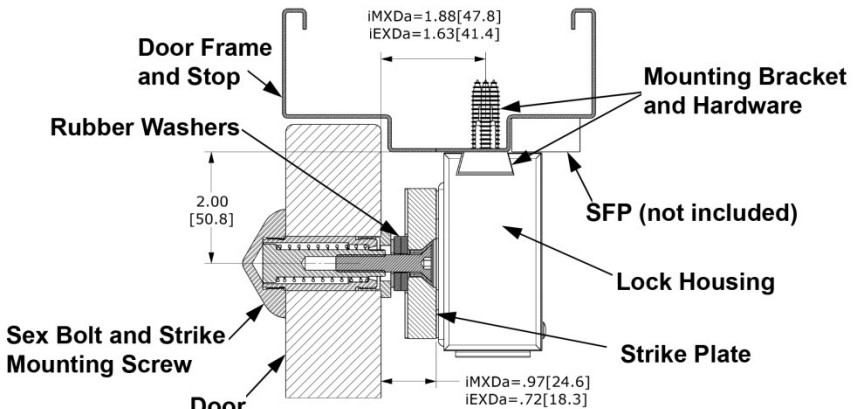

**Figure 2. Typical Section of Illustration (iMXDa)**

# Mounting the Strike

**NOTE:** Figure 3, "Typical Strike Mounting for the iMXDa," illustrates typical strike mounting for the iMXDa. For the iEXDa, the SB-MXD Sex Bolt, cap, and steel washer shown are replaced with a standard sex bolt.

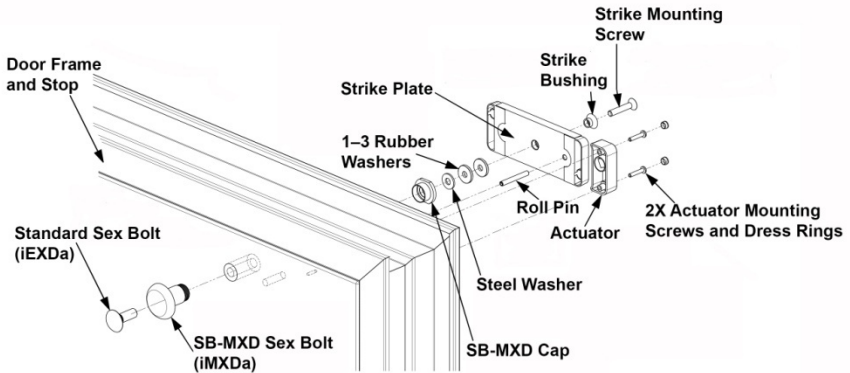

**Figure 3. Typical Strike Mounting for the iMXDa**

1. MOUNT the strike plate prior to the lock housing keeping the following items in consideration:
  - When installing the strike plate, the long edge of the strike must be at least 1/8" [3.2 mm] away from the door frame stop. The installed strike must allow the door to close properly.
  - At least 3/4" [19mm] clearance must be provided between the end of the lock and the corner of the door frame for tool access.
  - The entire mounting area for the lock bracket and housing must be a flat surface.
  - When installing the lock in the vertical position it is recommended that the strike be mounted with the roll pin oriented toward the top.
  - The external and internal areas of the marked door and frame should be checked for any mounting obstacles and necessary adjustments should be made to avoid these obstacles. The provided template for marking the mounting locations of the lock housing mounting bracket and strike should be used.
  - The installed lock (E-laminate) face and the strike plate must be aligned so that they are centered with each other.

  - a. Fully OPEN the door.
  - b. Carefully FOLD the template and PLACE into the desired location.
  - c. On the door, CENTER PUNCH the strike and actuator mounting holes marked [A] on the template.



- d. On the frame, CENTER PUNCH the slotted lock mounting holes marked [A] on the template.
- e. DRILL the 2 holes required for the strike in the door as noted on the template.
- f. INSTALL the provided roll pin into the back of the strike plate using a hammer.

**NOTE 1:** Steps “g” through “o” are completed for the installation of the iMXDa.

**NOTE 2:** The SB-MXD may be used to mark the two (2) pin holes by inserting the sex bolt into the hole from the outside of the door and lightly tapping the head with a hammer so that the pins mark the door where the holes are to be located. The head should be covered with a piece of cardboard to protect from marring, if necessary.

- g. MARK and DRILL the two 3/16” [4.8 mm] diameter holes for the pins of the SB-MXD on the outside of the door – these holes are designated [C] on the template.
- h. INSTALL the sex bolt through the hole in the door from the outside, engaging the pins into the holes.
- i. THREAD the cap onto the end of the sex bolt inside of the door, and TIGHTEN the assembly using a wrench.

**NOTE:** Use of two (2) rubber washers is recommended in the following step.

- j. In the following order, ASSEMBLE the strike mounting screw, strike bushing, strike plate, 1 to 3 rubber washer(s), and the steel washer.
- k. APPLY thread locking compound to the strike screw threads.
- l. THREAD the strike mounting screw into the sex bolt just a few threads, while aligning the roll pin into the hole in the door.
- m. PULL on the assembly (strike) to expose the end of the spring loaded plunger.
- n. With the plunger being held extracted, TIGHTEN the assembly using a wrench (or vise grip pliers) on the plunger end and a 3/16” hex key wrench in the socket head of the screw.
- o. RELEASE the assembly.

**NOTE:** Steps “p” through “u” are completed for the installation of the iEXDa.

- p. INSTALL the sex bolt through the hole in the door from the outside.
- q. , ASSEMBLE, in the following order, the strike mounting screw, strike bushing, strike plate and rubber washer(s) together.

- r. APPLY thread locking compound to the strike mounting screw threads.
- s. While holding the assembly together, THREAD the strike mounting screw into the sex bolt just a few threads, while aligning the roll pin into the hole in the door.
- t. PULL on the assembly (strike) to align and engage the knurled portion of the sex bolt into the hole.

**CAUTION: Over tightening of the strike/sex bolt assembly can cause damage to the rubber washers and may prevent proper operation or a reduction in holding strength of the unit.**

- u. While keeping the assembly aligned, TAP the head of the sex bolt into place using a hammer, and TIGHTEN the assembly using a 3/16" hex key wrench in the socket head of the screw.

## Mounting the Actuator

1. DRILL the two (2) previously marked actuator mounting holes as noted on the template.
2. INSTALL the actuator to the door using a #2 Phillips screwdriver and the provided screws.

## Mounting the Lock Housing

**NOTE 1:** Figure 4, "Installing the Lock Housing," provides illustration for the following steps.

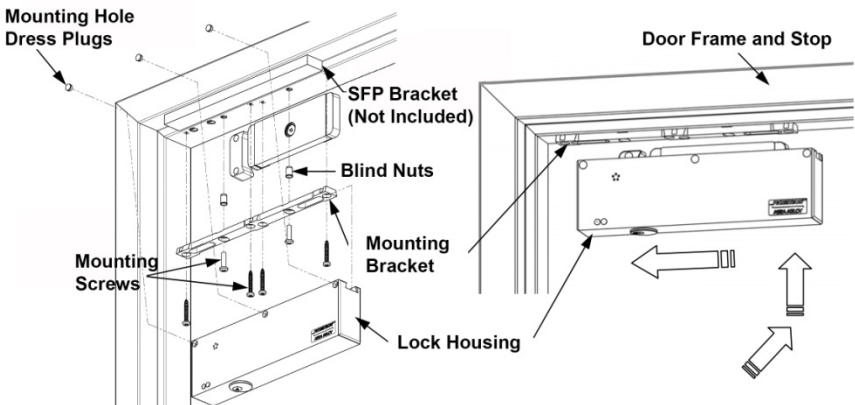

**Figure 4. Installing the Lock Housing**

**NOTE 2:** At least two (2) blind nuts (as specified by the template) must be used for installing the mounting bracket to aluminum and/or hollow metal frames.

**NOTE 3:** Steps 1–3 are for a metal door frame.

1. DRILL two 3/8" [9.5 mm] diameter holes and one 1/2" [12.7 mm] diameter hole at the three previously hole positions marked [A] on the frame.
2. INSTALL two 1/4-20 blind nuts into the 3/8" diameter holes (see the section for details of how to install the blind nuts).
3. ATTACH the lock mounting bracket to the frame using a #3 Phillips screwdriver and the two 1/4-20 UNC X 1" long machine screws,

**NOTE:** Steps 4–5 are for a wood door frame.

4. DRILL two 3/16" [4.8 mm] diameter holes X 1-1/4" [32 mm] deep (minimum) and one 1/2" [12.7 mm] diameter hole through the frame at the previously marked [A] hole positions.
5. ATTACH the lock mounting bracket to the frame using a #3 Phillips screwdriver and two #12 X 1-1/2" long Type "A" screws.
6. LOOSEN the two mounting screws enough to allow movement of the bracket.
7. ASSEMBLE the lock onto the bracket.
  - a. SHIFT the unit to one side (approximately 1-1/2").
  - b. ENGAGE the top of the housing onto the bracket.
  - c. SLIDE the bracket back toward center (see Figure 4).
  - d. ENSURE the lock is centered on the bracket.
8. ADJUST the lock (and bracket) into position, making contact with the face of the strike.
9. MARK the door frame at each end of the assembly to indicate the position of the mounting bracket, and then carefully REMOVE the lock from the bracket.
10. RE-ALIGN the bracket to the position marks, as necessary.
11. TIGHTEN the two bracket mounting screws fully using a screwdriver.
12. Using the mounted bracket as a guide, CENTER PUNCH the frame at the four remaining mounting holes marked [B] on the template.

**NOTE:** Steps 13–14 are for a metal door frame.

13. DRILL four 3/16" [4.8 mm] diameter holes through the frame.
14. SECURE the bracket to the frame using a #3 Phillips screwdriver and the four #12 X 1-1/2" long Type A screws.

**NOTE:** Steps 15–16 are for a wood door frame.

15. DRILL four 7/32" [5.5 mm] diameter holes X 2-3/4" [70mm] deep (minimum) into the frame.

16. SECURE the bracket to the frame using a #3 Phillips screwdriver and four #14 X 3" long Type "A" screws.
17. ASSEMBLE the lock onto the mounting bracket.
18. TIGHTEN the three set screws along the upper/back side of the unit to secure using a 3/32" hex wrench.
19. CHECK lock mount assembly for adequate tightness and secure installation.
20. MAKE wire connections, APPLY power, and TEST for proper operation.
21. After completing wiring and testing, ENSURE that the three set screws in the top/rear of the lock housing are tight and the lock is secure.
22. INSERT the provided dress plugs into the lock set screw and actuator mounting holes.

## Installing the Blind Nuts

**NOTE:** Figure 5, "Installing Blind Nuts," provides illustration to the steps in this section.

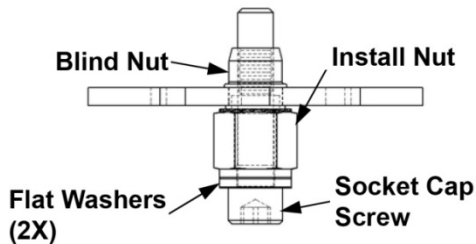

**Figure 5. Installing Blind Nuts**

1. INSTALL a blind nut into each of the 3/8" [9.5 mm] holes specified by the template using the provided blind nut collapsing tool.
    - a. INSERT the assembled blind nut installation tool provided into a mounting hole.
    - b. HOLD the install nut using a 1/2" [13 mm] box or open end wrench.
    - c. TURN the socket cap screw and COLLAPSE the blind nut using a 3/16" [5.0mm] hex wrench.
    - d. REMOVE the collapsing tool when finished.
- NOTE:** The collapsing tool is reusable for several blind nut installations
- e. VERIFY that the blind nut is securely collapsed.

# Replacing the Mortise Cylinder and Cam

## General

The mortise cylinder and cam is field replaceable. The cylinder is retained by a knurl-nut and bracket to ensure proper alignment and provide anti-rotational support. The nut is removable, and may be loosened or tightened by using a flat-blade screwdriver.

## Alternate Cylinders

Cylinders must be 1-1/8" [28.6mm] deep for proper alignment with the mode selection switch. The use of 1" [25.4mm] or 1-1/4" [31.8mm] cylinder is not recommended. Figure 6, "Recommended Cylinder Dimensions," specifies the recommended dimensions. If a longer cylinder is used, a spacer ring must be added for proper alignment.

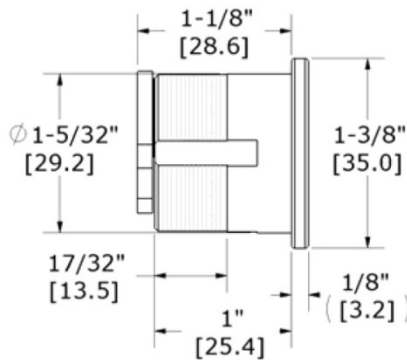

Figure 6. Recommended Cylinder Dimensions

## Alternate Cams

Various cam types will operate in the iMXDa/iEXDa. Cam dimensional references with minimum/maximum variables are illustrated in Figure 7, "Cam Dimensional References." Figure 8, "Alternate Cams," displays cams tested for use in the iMXDa/iEXDa. The 13-0097 Cam is factory installed. Other cams may be used.

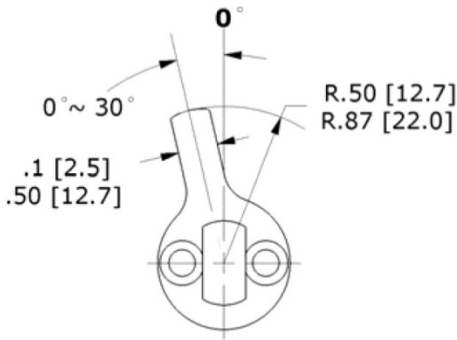

Figure 7. Cam Dimensional References

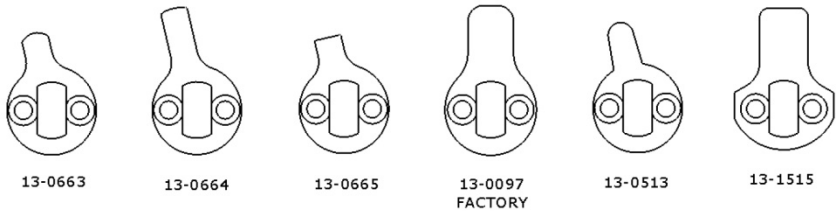

Figure 8. Alternate Cams

## Installing the Electrical Connections

### General Characteristics

The iMXDa/iEXDa is a low current device that uses specialized internal circuitry to suppress inductive kick-back.

### Electrical Standards

DC voltage, full-wave rectified, must be provided for proper operation of the iMXDa/iEXDa. The positive (+) terminal receives +12 VDC or +24 VDC, and the negative (-) terminal, 0 Volts. If the unit is connected with reverse polarity, it will not operate. The iMXDa and iEXDa are auto sensing dual voltage lock systems.

### Sensor Ranges (Electrical)

The internal bond monitoring system of the Magnalock is not only sensitive to the proper physical position of the strike, but also voltage. Proper voltage in the range specified must be applied.

# Electrical Wiring

All wiring to the installed unit is made to the main terminal strip on the PC board inside the wire access compartment.

## Power Supply Connections

1. CONNECT the iMXDa/iEXDa to various Securitron power supplies in accordance with Figure 9, "Connecting to a 1-Amp Power Supply (BPS-12-1 or BPS-24-1)," Figure 10, "Connecting to a 2–4.5 Amp (BPS) Power Supply," Figure 11, "Connecting to a 6–15 Amp (BPS) Power Supply," or Figure 12, "Connecting the iMXDaCH to a BPS-CH Power Supply."

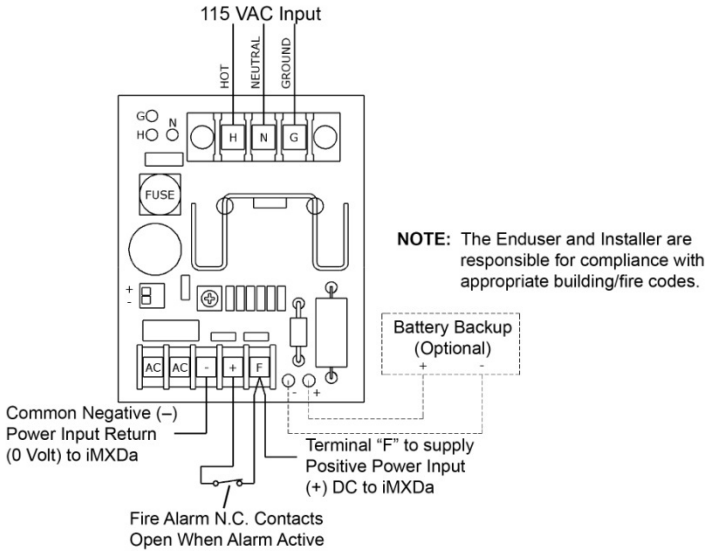
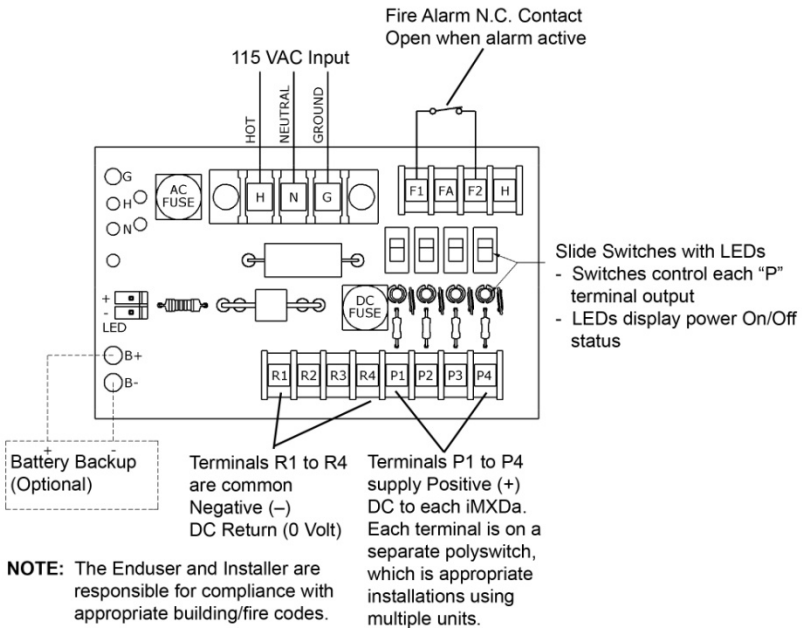
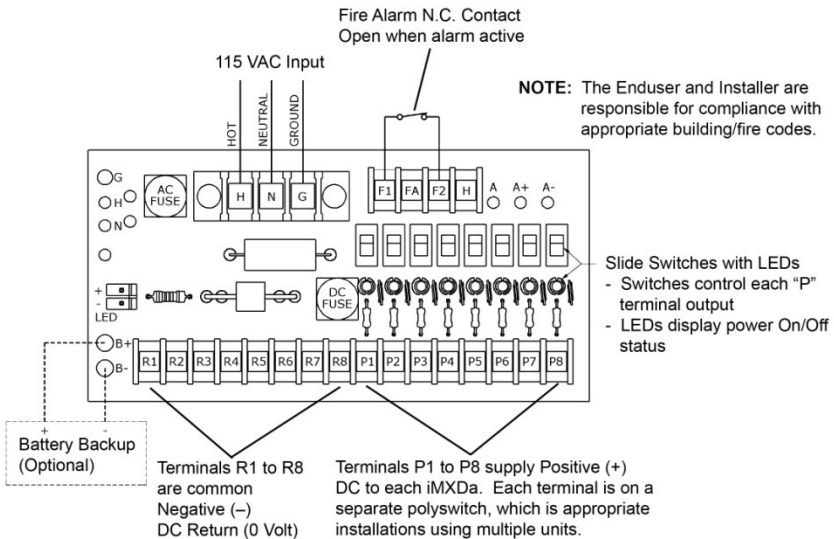

Figure 9. Connecting to a 1-Amp Power Supply



**Figure 10. Connecting to a 2-4.5 Amp (BPS) Power Supply**



**Figure 11. Connecting to a 6-15 Amp (BPS) Power Supply**



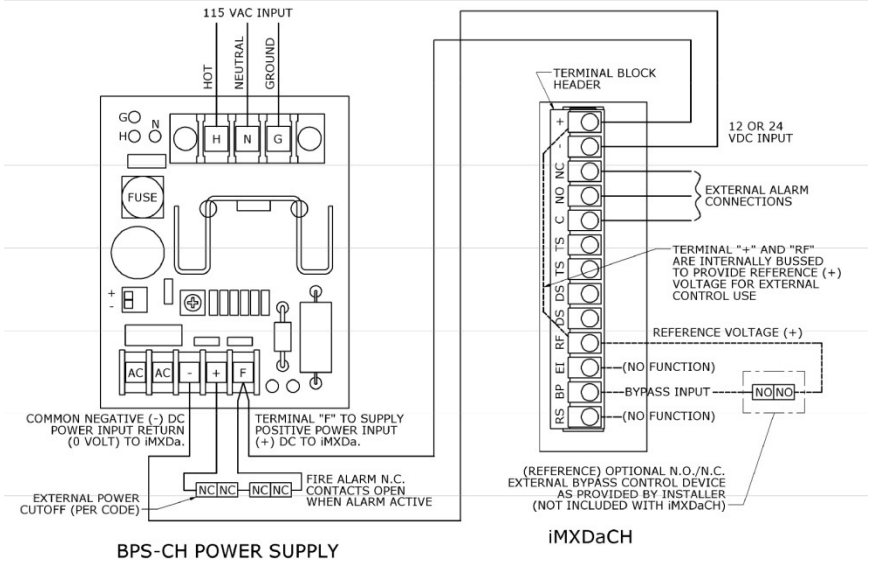

Figure 12. “Connecting the iMXDaCH to a BPS-CH Power Supply.”

## Emergency Release

Integrated exit delay Magnalock units are typically wired into the building fire protective or sprinkler system. It is recommended to use the fire alarm system auxiliary relay to perform break of power. Securitron power supplies have terminals for interconnection to such emergency release switches.

## SYSTEM OPERATIONS

### General Operations Description

The iMXDa uses a M62 Series Magnalock to secure an opening. When there is an attempt to exit, the SB-MXD sex bolt permits the door to move within a 1” limit while remaining secure. The door movement distance (or gap) for an alarm is set by “training” the unit’s microprocessor to trigger at a desired distance. Whenever this programmed door movement is detected, the unit initiates an alarm, and during this alarm sequence, there is a release delay where the local alarm inside the housing sounds and a remote alarm contact activates. At the end of the alarm sequence, the lock releases, the local alarm stops, but the external alarm contact remains active. The unit remains in the released state until it is either manually or automatically relocked (reset). Reset must be accomplished manually by the momentary turn of the Integrated Reset/Bypass (IRB) key switch or performed through a remote input.

# Component Layout

Figure 12, “General Layout and Position of the PC Board in the Wire Access Compartment,” provides illustration of the iMXDa/iEXDa for this section.

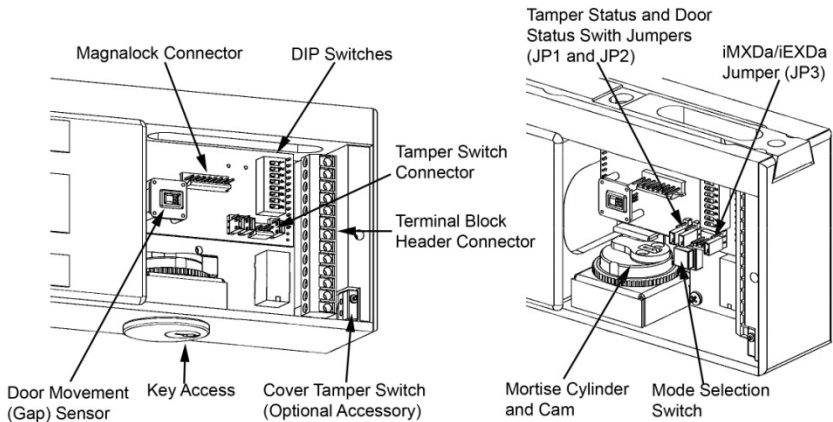

**Figure 12. General Layout and Position of the PC Board in the Wire Access Compartment**

## Power On Reset

Power on reset is a start up function that is initiated whenever power is applied to the iMXDa unit. At power up, the iMXDa locking system performs the following self diagnostics:

- Validates program version
- Reads DIP switch settings
- Verifies door position
- Confirms lock status secure
- Initiates standard operational mode

## Integrated Reset/Bypass (IRB) Key Switch

The iMXDa/iEXDa incorporates a mortise lock cylinder and cam that are accessible from the bottom of the lock housing (see Figure 12). This Integrated Reset/Bypass (IRB) key switch is required for gap adjustment and activation of the reset and bypass functions. The furnished cylinder is replaceable with a variety of commercial cylinder/cam combinations.

## Standard Operational Mode

This iMXDa unit operates in this mode most of the time. When the door is closed, and the magnet is secure, the green LED is on.

The green and red LEDs provide visual status. The functional unit LED indications are as follows:

- Green LED is on when the door is closed and secure.
- Red LED is on when an alarm event has released the door and it is awaiting reset.
- Green and red LEDs are on when the system is in an alarm sequence.
- Green and red LEDs are off if the lock is not powered or is in bypass mode.

## **Bypass Mode — IRB (or External)**

Bypass mode allows a timed momentary release of the door, and can be entered via the onboard IRB key switch or an external switch. Using the onboard IRB key switch provides a fixed 15-second door release with automatic relocking. During an alarm event, bypass can be used for emergency exit.

## **Reset — IRB (or External)**

Reset relocks the door after an alarm event, and is accomplished by manually turning the onboard IRB key switch clockwise. Reset can also be accomplished using an external switch.

# **System Functions**

## **General**

The following is a general description of the iMXDa lock system functions and DIP switch settings. For DIP switch location see Figure 12. DIP switch setting changes are recognized at the microprocessor when:

- Power is applied to the lock.
- During a bypass event (prior to the door being closed).
- After an alarm event (prior to reset).

Figure 13, "Factory Default DIP Switch SW1–SW8 Settings," Figure 14, "California DIP Switch SW1–SW8 Settings," Figure 15, "Chicago DIP Switch SW1–SW8 Settings," and Table 1, "DIP Switch Settings Matrix," provide a complete illustration of DIP switch settings and their functions.

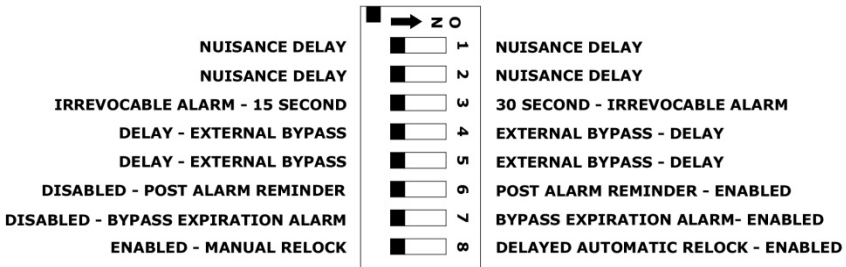

**Figure 13. Factory Default DIP Switch SW1–SW8 Settings**

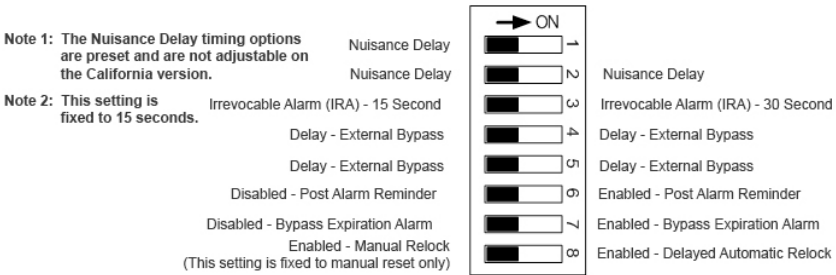

**Figure 14. California DIP Switch SW1–SW8 Settings**

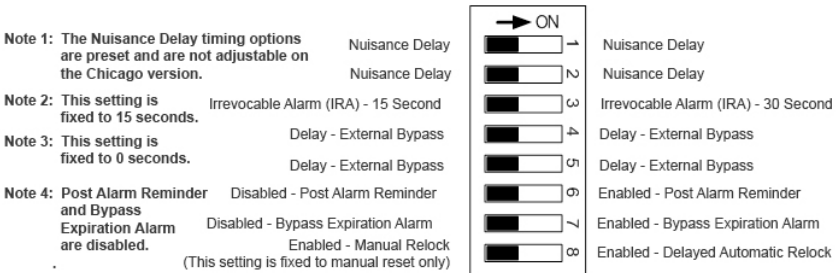

**Figure 15. Chicago DIP Switch SW1–SW8 Settings**

**Table 1. DIP Switch Settings Matrix**

Operation	8-Position DIP		Directive	Factory Default Settings	California Settings	Chicago Settings
	SW1	SW2	Seconds			
~ NDA ~ Nuisance Delay Alarm	OFF	OFF	0	✓		
	ON	OFF	1		✓ fixed	✓ fixed
	OFF	ON	2			
	ON	ON	3			

Operation	8-Position DIP		Directive	Factory Default Settings	California Settings	Chicago Settings
~ IRA ~ Irrevocable Alarm	<b>SW3</b>		<b>Cycle Time</b>			
	OFF		15	✓	✓ fixed	✓ fixed
	ON		30			
~ BDT ~ Bypass Delay Time (External Only)	<b>SW4</b>	<b>SW5</b>	<b>Seconds</b>			
	OFF	OFF	0	✓	✓	✓ fixed
	ON	OFF	5			
	OFF	ON	10			
	ON	ON	15			
~ PAR ~ Post Alarm Reminder	<b>SW6</b>		<b>Function</b>			
	OFF		Disabled	✓	✓	✓ fixed
	ON		Enabled			
~ BEA ~ Bypass Expiration Alarm	<b>SW7</b>		<b>Function</b>			
	OFF		Disabled	✓	✓	✓ fixed
	ON		Enabled			
~ MDR ~ Manual/Delayed Relock	<b>SW8</b>		<b>Function</b>			
	OFF		Manual	✓	✓ fixed	
	ON		Delayed			✓ fixed

## Nuisance Delay Alarm (NDA) — DIP Switches SW1 and SW2

NDA is a 0-, 1-, 2-, or 3-second nuisance or warning delay (revocable) that initiates when door movement is detected. When triggered, the local alarm (pulsing tone) will sound. The factory default setting is 0; settings are changed using DIP switch settings of SW1 and SW2. This setting is fixed to 1 second on the California and Chicago versions.

## Irrevocable Alarm (IRA) — DIP Switch SW3

IRA is an irrevocable alarm that initiates when door movement is detected. Once initiated, the complete delay cycle must expire prior to reset. This is a set 15- or 30-second total alarm time cycle. The audible alarm sounds until the IRA expires. The factory default setting is 15 seconds, but can be changed to 30 seconds by changing DIP switch SW3. This setting is fixed to 15 seconds on the California and Chicago versions.

## Bypass Delay Time (BDT) — DIP Switches SW4 and SW5

BDT is a bypass function only. Once triggered, a set 0-, 5-, 10- or 15-second release time is initiated. The factory default setting is 0, but can be set to 5, 10 or 15 seconds (trailing edge trigger) by changing DIP switches SW4 and SW5. This setting is fixed to 0 seconds on the Chicago version.

## Post Alarm Reminder (PAR) — DIP Switch SW6

PAR is an audible alarm indicating the lock has completed an alarm cycle. After 5 seconds, the internal alarm will rapidly beep 3 times, followed by 5 seconds of silence, and will then repeat until reset. The factory default setting is off, but PAR can be turned on with DIP switch SW6. This setting is disabled on the Chicago version.

## Bypass Expiration Alarm (BEA) — DIP Switch SW7

The bypass expiration alarm is an audible, rapid, 4-beep signal that repeats three (3) times over a 5-second time period. This indicates that the bypass time period has expired and the door must be closed; if not, the lock will go into alarm mode. The factory default setting is off, but this function can be turned on via DIP switch SW7. This setting is fixed to 0 seconds on the Chicago version.

## Manual/Delayed Relock (MDR) — DIP Switch SW8

The manual/delayed relock allows either manual relock or delayed (30-second) automatic relock. The factory default setting is manual relock, but this can be changed with DIP switch SW8. Delayed relock is fixed in the on position on the Chicago version. Delayed relock is disabled on the California version.

# Alarms

## Internal (Local) Alarm

The internal alarm of the iMXDa/iEXDa lock system consists of an 85–100 dB electronic (Piezo) sounder. This audible alarm functions during alarm cycles, post alarm reminders and bypass egress time expiration.

## External (Remote) Alarm

The external alarm for the iMXDa/iEXDa consists of an integrated SPDT [single pull double throw] dry contact with connection points marked “C”, “NO” and “NC”. At the initiation of an alarm sequence, or at the loss of power, the relay de-energizes to provide a signal to an alarm or monitoring system.

# Control Wiring

## Wiring Layout

Figures 16, “General Control Board Diagram,” Figure 17, “Optional External Control Connections,” and Figure 18, “Selectable Output Jumper Positions,” provide illustration for this section.

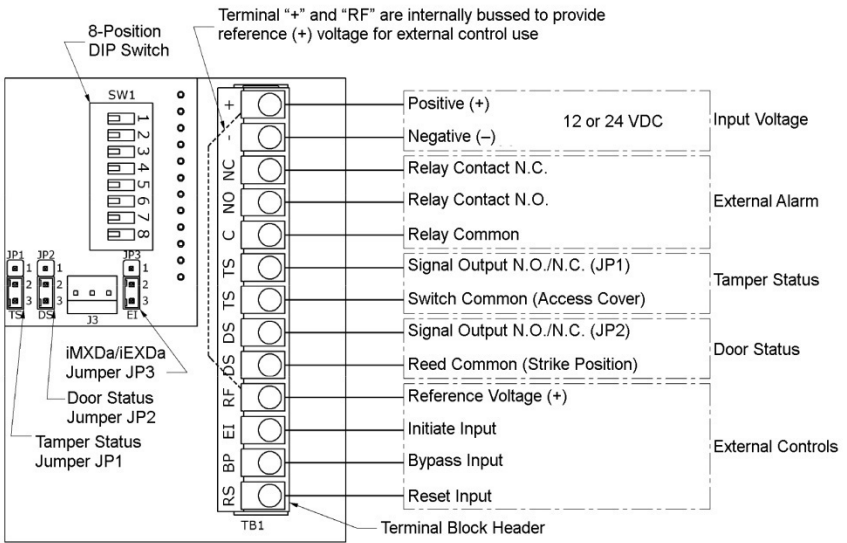
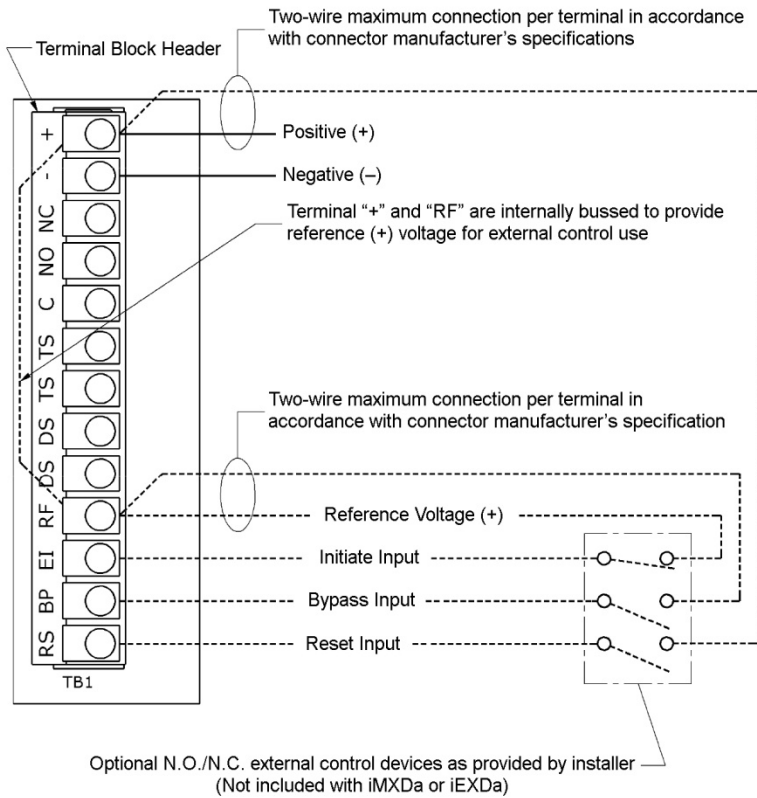
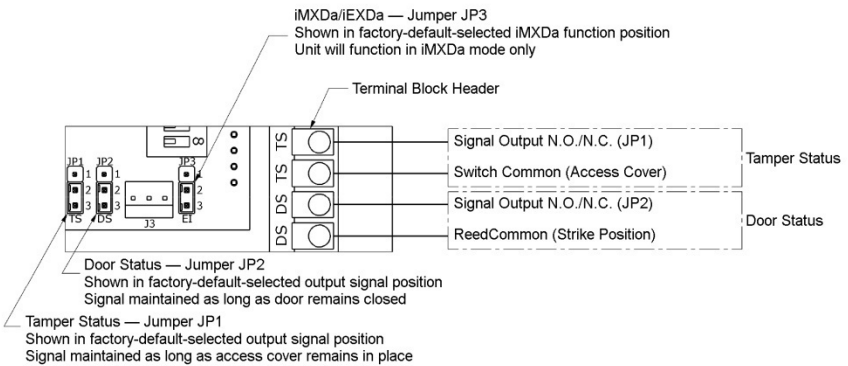

Figure 16. General Control Board Diagram



**Figure 17. Optional External Control Connections**



**Figure 18. Selectable Output Jumper Positions**



## External Controls

The unit has terminals that provide the necessary connections for remote control of specific functions. Figure 16 shows examples of the following connections:

- The “RS” terminal provides a connection for remote reset.
- The “BP” terminal provides a connection for remote bypass.
- The “EI” terminal provides a connection for external initiate of exit delay. To operate the external initiate (iEXDa), the JP3 jumper, which by factory default is placed over pins 2 and 3, must be removed and placed over pins 1 and 2 (see Figure 17).
- The “RF” terminal is a common reference (+) voltage supply point that may be used for the above described external controls.

## External Initiate (iEXDa)

External initiate is normally used to provide access using an exit device rather than door movement. The remote make-to-break device is wired to provide a signal that triggers the lock to release. All lock function DIP switch settings remain intact. The actuator must be installed for activation of the door movement (gap) sensor. The sensor is used to monitor door position for post alarm, bypass reminder, and relock functions.

## Tamper Status (JP1) and Door Status (JP2) wiring

The Tamper Status function can only be operated in units equipped with an XDAT-KIT. This kit is sold separately and includes an alternate lock housing end cap, and implements a micro switch which supplies a signal when the front cover of the housing is accessed. The installation and operating instructions included with the kit detail proper installation.

The tamper status and door status switches provide dry contact output at the terminal block header. Output is field selectable via the jumpers shown in Figure 18. The factory default jumper settings for both JP1 and JP2 are set for normally closed operation (pins 2 and 3). If normally open operation is desired, change the jumper setting to pins 1 and 2.

## Wire Gauge and Length

### General

The iMXDa/iEXDa requires adequate voltage and current for proper operation; both of which can be affected by resistance. Resistance is created by the length and gauge (size) of the wire being used. The following factors need to be considered in determining proper wire length and gauge:

- An accurate estimated distance from the power supply to the opening is crucial.

- For optimum operation, the correct size gauge wire must be used.
- The devices being used operate best with the least amount of resistance on the source.
- Using the correct gauge wires protects against large voltage and current (load) losses.
- The gauge is determined by the wire distance, voltage, and current of all devices.

## Determining Wire Gauge and Length

**NOTE:** Table 2, “12 VDC System Wire Gauge and Length,” and Table 3, “24 VDC System Wire Gauge and Length,” provide the proper system wire gauge and length based on current draw.

1. DETERMINE proper wire gauge and length by following Example A for a 12 VDC system and Example B for a 24 VDC system, and using Tables 2 and 3.

**Example A:** iMXDa used in a 12 VDC System;  
200 feet of wire needed one-way

Devices Used	Current Draw (Amps)	Running Total (Amps)
iMXDa	0.370	0.370
DK-26 Access	0.160	0.530
MK Bypass/Reset	0.020	0.550
Total Current (Rounded Up to Nearest Tenth)		0.600

Using Table 2 and intersecting the total current draw of 0.600A and the required wire length of 200', a wire gauge of 18 is required.

**Example B:** iEXDa used in a 24 VDC System;  
200 feet of wire needed one-way

Devices Used	Current Draw (Amps)	Running Total (Amps)
iEXDa	0.270	0.270
TSB Touch Bar	0.025	0.295
DK-11 Access	0.070	0.365
Total Current (Rounded Up to Nearest Tenth)		0.400

Using Table 3 and intersecting the total current draw of 0.400A and the required wire length of 200', a wire gauge of 18 is required.

**Table 2. 12 VDC System Wire Gauge and Length**

Current	Wire Gauge								
	1.000A	20	18	16	14	14	12	10	10
0.800A	22	18	18	16	14	12	10	10	8
0.600A	22	20	18	18	16	14	14	12	10
0.400A	22	22	20	18	18	16	14	14	12
0.300A	24	22	22	20	18	18	16	14	14
0.200A	24	22	22	22	20	18	18	16	14
	50' [15m]	100' [30m]	150' [46m]	200' [61m]	300' [91m]	400' [122m]	500' [152m]	750' [229m]	1000' [305m]
Wire Distance									

**Table 3. 24 VDC System Wire Gauge and Length**

Current	Wire Gauge								
	1.000A	22	20	20	18	16	14	14	12
0.800A	22	22	20	18	18	16	14	14	12
0.600A	24	22	22	20	18	18	16	14	14
0.400A	24	22	22	22	20	18	18	16	14
0.300A	24	24	22	22	22	20	20	18	16
0.200A	24	24	24	22	22	22	20	20	18
	50' [15m]	100' [30m]	150' [46m]	200' [61m]	300' [91m]	400' [122m]	500' [152m]	750' [229m]	1000' [305m]
Wire Distance									

## Adjusting the Gap (iMXDa only)

**NOTE:** The iMXDa may be “trained” to trigger at any desired gap distance between 1/8” and 1”. The Chicago version is limited to a 1/8” gap.

1. To access the gap adjustment mode, ENSURE that the door is at rest in the closed position.

**NOTE 1:** The switch must be actuated three (3) consecutive times within a five (5) second period.

- The first switch actuation will cause both LEDs to go off.
- The second switch actuation will cause the red LED to blink on and off once.
- After the third switch actuation, the green and red LEDs will alternate on and off for one (1) second, and then the red LED will remain on.

**NOTE 2:** Following this step, the iMXDa unit has read and stored the closed position of the door.

2. INSERT the key into the IRB cylinder and ROTATE clockwise to actuate the mode selection switch.

**NOTE 1:** Following this step, the red LED will be off and the green LED will be on.

**NOTE 2:** The door movement (gap) distance is now set.

3. OPEN the door to the desired (gap) distance, and then TURN the key clockwise once.
4. CLOSE the door and the unit is adjusted and ready for operation.

## Installing the EXD-1L Label

**NOTE:** Each iMXDa and iEXDa comes with an EXD-1L exit delay door label as required by fire code.

1. FOLLOW the included application instructions to apply the lettering to a door.

## Specialized Mounting Brackets

The Stop Filler Plate (SFP) bracket is designed to fill the stop rabbit and extend the flat mounting surface of the frame head. Available thicknesses are; 1/4" [6.4mm], 3/8" [9.5mm], 1/2" [12.7mm], and 5/8" [15.9mm]. Length available for the iMXDa is 12" [305mm].

## Operational Information

### State of California – iMXDa-CA

This addresses the operating notifications specifically related to compliance with the state of California building codes 2011 update.

State of California approved Delayed Egress devices shall conform to all of the following:

1. The doors unlock upon actuation of the automatic sprinkler or smoke detection system.
2. The doors unlock upon loss of electrical power to anyone of the following:
  - a) The egress system itself
  - b) The smoke detection system
3. The door shall have the capability of being unlocked by a signal from a switch located in an approved area.

4. A sign shall be provided on the door located above and within 12 inches (25 mm) of the releasing device reading (KEEP PUSHING. THIS DOOR WILL OPEN IN 15 [30] SECONDS. ALARM WILL SOUND.) Sign lettering shall be at least 1 inch (25 mm) in height and shall have a stroke of not less than 1/8 inch (3.2 mm).
5. Actuation of the panic bar or other door latching hardware shall activate an audible signal at the door.
6. Regardless of the means of deactivation, the relocking of the egress control device shall be by manual means only at the door.

## **City of Chicago – iMXDa-CH**

This addresses the operating notifications specifically related to compliance with the City of Chicago and related Municipal Codes.

### **For compliance with Section 13-160-269(a)(7) of the Municipal Code:**

- The Securitron – Model iMXDa-CH Integrated Movement Exit Delay System will contain no selectable operating modes for the logic timers or specialized alarm reminder operations.
- The timing system is fixed with a 1 second initiating time (nuisance timed alarm) plus a 14-second (Irrevocable timed alarm) sequence and delayed lock release and egress implementation.
- Automatic re-locking only occurs if the door opens and returns to the closed position and then remains closed for a full 30 second period thereafter.

### **For compliance with Section 13-160-269(a)(1) of the Municipal Code:**

- The Securitron – Model iMXDa-CH Integrated Movement Exit Delay System must be used with a UL listed fire alarm system.
- The fire alarm system must contain latching type dry contacts designated for “auxiliary” operations.
- The contacts must activate for both the alarm and troubled conditions.

### **For compliance with Section 13-160-269(a) of the Municipal Code:**

- The Securitron – Model iMXDa-CH Integrated Movement Exit Delay System must be used with a Securitron ~ Model BPS-CH Series Power Supply.
- The power supply unit is to be supplied without provisions for battery back-up.

## **Door Travel Limitations and/or Restrictions :**

- The Securitron – Model iMXDa-CH Integrated Exit Movement Delay System must be configured to trigger the egress initiating within one-eighth inch (1/8”) of door movement.
- The maximum door travel is limited to a one-half inch (1/2”) movement measured at the strike amature/sex bolt mounting location.

# **MAGNALOCK MAINTENANCE**

## **Performing an Inspection**

1. CHECK the rubber washers for elasticity and proper pivoting; and TIGHTEN, as required.
2. CHECK for build-up of debris on the magnet face and strike amature, and CLEAN, as required.
3. CHECK for rust on the magnet and strike plate amature; and CLEAN, as required.
4. CHECK for iron debris on the actuator and strike (DPS) magnetic housings; and REMOVE, as required.

**NOTE 1:** Cleaning once a year is recommended.

**NOTE 2:** Cleaning every six months is recommended where minor rusting occurs.

**NOTE 3:** Cleaning every three months is recommended if rusting conditions are severe.

## **Cleaning the Magnalock**

1. APPLY rubbing alcohol onto a clean cloth and thoroughly WIPE DOWN the Magnalock and strike plate amature.
2. USE a plastic dishwashing scrub pad to aid in the removal of rust.

# **TROUBLESHOOTING**

## **No alarm when testing door movement**

1. CHECK for specified voltage to the unit.
2. CHECK for specified current draw at the unit.

3. CHECK the magnetic actuator for proper mounting.
4. ENSURE gap testing and training of unit.

**Immediate alarm when testing movement**

1. CHECK for proper door closure.
2. CHECK magnetic actuator for proper mounting.
3. Check lock housing and strike for proper mounting.
4. ENSURE Jumper JP3 is in the correct position.
5. ENSURE that the circuit connected to the "EI" terminal is properly functioning. (iEXDa only)
6. ENSURE gap testing and training of unit. (iMXDa only)

**Lock does not generate a magnetic field**

1. See Reduced Holding Force section.

**Magnalock has reduced holding force**

1. CHECK for specified voltage at Magnalock.
2. CHECK for specified current draw at Magnalock.
3. CHECK the strike for proper mounting.
4. CHECK Magnalock and strike for obstructions.
5. ENSURE that Magnalock and strike are properly cleaned.

**DPS does not report door status**

1. CHECK strike mounting for proper alignment.
2. CHECK for proper door closure.
3. CHECK for proper voltage/current on the switch.
4. CHECK resettable protection (polyswitch overload).

**The Magnalock is dirty or rusty**

1. ENSURE Magnalock is clean.

**Electronic noise interference with Access Control System**

1. CHECK for voltage from Magnalock to door frame to ensure there is no voltage present.

## **Securitron**

10027 S. 51st St. Ste 102

Phoenix, AZ 85044

Tel: 1-800-624-5625

Mon-Fri: 6:00am - 4:00pm PDT

Fax: 1-800-232-7329

**securitron.com**



ASSA ABLOY, the global leader  
in door opening solutions