

M1510/M1520C FUNCTION CHANGE INSTRUCTIONS

FOR USE WITH THASE ENTERPRISE M2000 SERIES MORTISE LOCKS

Installation:

1. Remove the cover from the lock case.
2. Locate the solenoid body within the cutout of the solenoid locating plate:
 - A. For fail-safe (M1510C) function, the solenoid plunger should extend from the solenoid body toward the face plate of the lock.
 - B. For fail-secure (M1520C) function, the solenoid plunger should extend from the solenoid body toward the back of the lock.
3. Rotate the solenoid body within the cutout such that the lead wires are close to the solenoid plate. **Failure to do so may cause the lead wires to interfere with the movement of the mechanism.**
4. Route the lead wires along the body of the solenoid and under the clamp. Verify the lead wires are not interfering with the movement of the mechanism.
5. Attach the cover to the lock case.

FAIL-SAFE (M1510C)

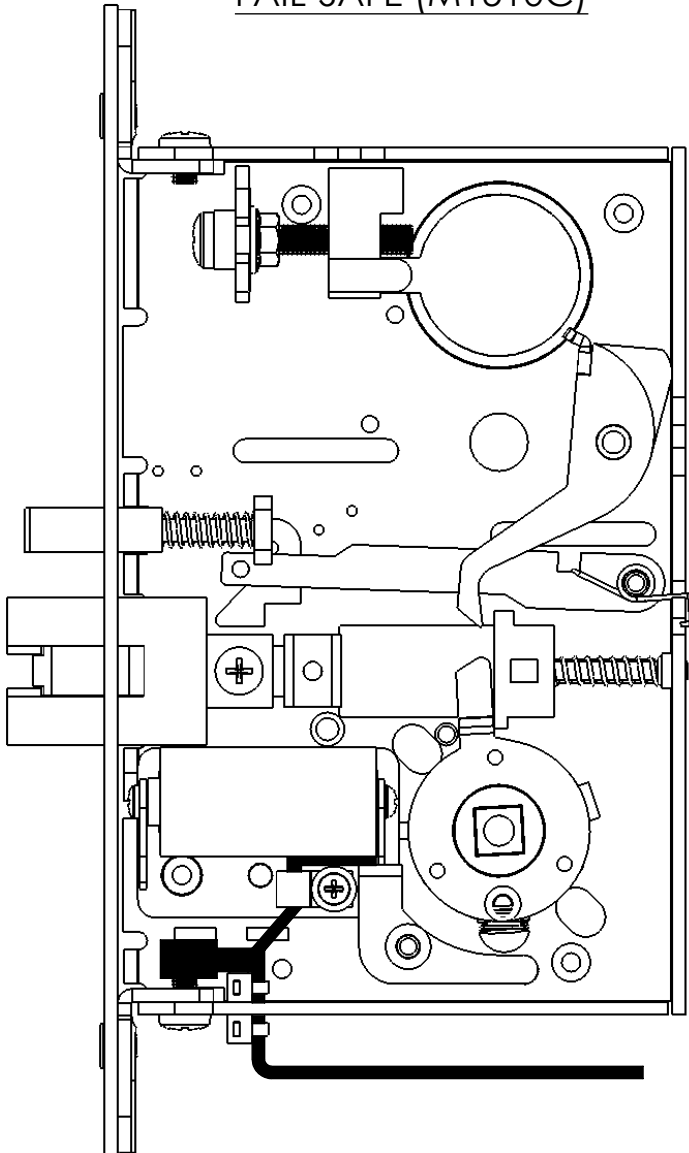

FAIL-SECURE (M1520C)

