

II-C1500-9

INSTALLATION INSTRUCTIONS

FALCON T561

CYLINDRICAL AE (AUTHORIZED EGRESS) MONITORING.

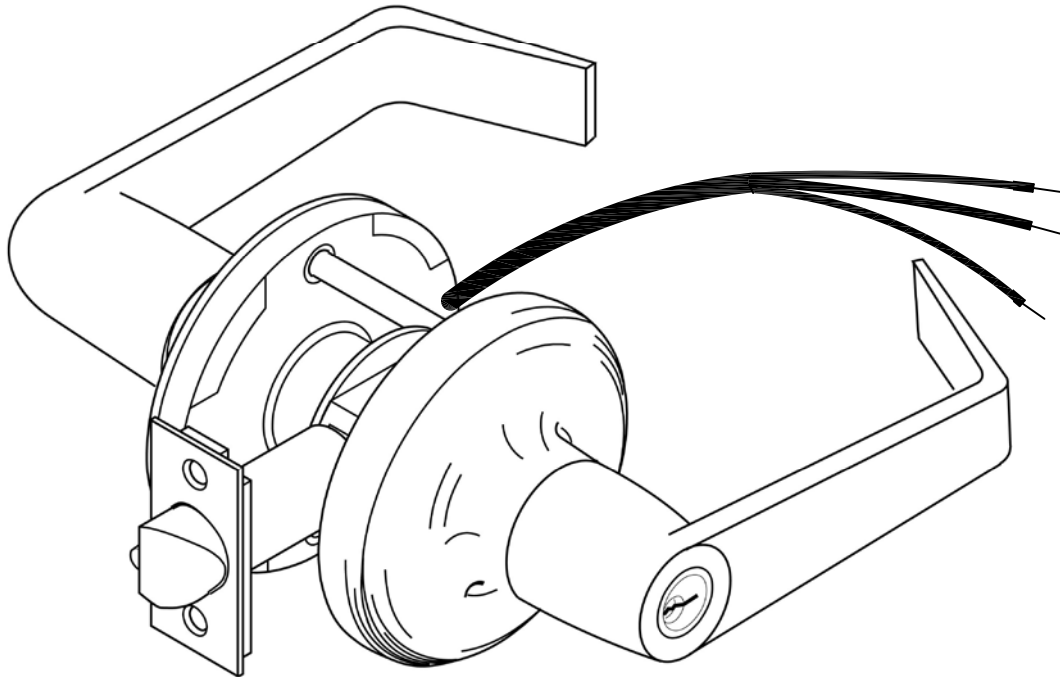

TERMINATE THE WIRES FROM LOCK TO THE ELECTRIC POWER TRANSFER DEVICE USING 22 AWG WIRE. USE PROPER CRIMP SPLICES OR WIRE NUTS FOR TERMINATING CONNECTIONS.

3 - WIRE AE MODIFICATION UTILIZES A UL RECOGNIZED SPDT SWITCH PROVIDING A CHOICE OF:

- NORMALLY CLOSED OPERATION USE THE YELLOW (COM.) & GRAY WIRES
- NORMALLY OPEN OPERATION USE THE YELLOW (COM.) & RED WIRES

ELECTRICAL SPECIFICATIONS

- 30 VDC @ .5 AMP MAXIMUM
- WIRE LEADS: 22 AWG

