



Instruction Sheet Industrial Flow Switch

102-022

SUPERCEDES: 102-022 DATED March 17, 2004

EFFECTIVE: June 28, 2010

5401110-REV E-1



CE
(IFS01 & IFS02
ONLY)

GENERAL

The Model IFS is a flow switch used in liquid flow lines carrying water or any fluid not harmful to brass, stainless steel, or EPDM and not classified as a hazardous fluid.

This switch can serve as a way to start and stop electrically operated equipment when a flow or no flow condition occurs in a variety of applications.

This device is designed for use only as an operating control. Where an operating control failure would result in personal injury and/or loss of property, it is the responsibility of the installer to add devices (safety, limit controls) that protect against, or systems (alarm, supervisory systems) that warn of control failure.

Listings/Approvals:

- UL Guide (NKPZ) for industrial control equipment per UL Standard 508 Industrial Control Equipment
- UL Guide (MFHX) for heating/cooling appliance switch per UL Standard 353 Limit Controls
- CSA Class (321106) for industrial control equipment per CSA Standard C22.2 No. 14-M Industrial Control Equipment

Maximum Service Pressure: 250 PSI

Enclosure:

NEMA Type 1 (For indoor use only)
Formed sheet metal with powdercoat finish.
Not for use in hazardous locations.

Contacts:

IFS01: One SPDT (Form C) switch
IFS02: Two sets of SPDT (Form C) switches to provide versatility in wiring two separate circuits.
15 Amps at 125/250VAC
.5 Amps at 125VDC
.25 Amps at 250VDC

Motor Ratings : 120VAC 240VAC

Horsepower : 1/8 1/4

AC F.L.A. : 3.8 2.9

AC L.R.A. : 22.8 17.4

Pilot Duty Rating : 125 VA/120/240 VAC

IFSH1/2 Contacts:

IFSH1: One SPDT (Form C) switch
IFSH2: Two sets of SPDT (Form C) switches to provide versatility in wiring two separate circuits.
22 Amps at 125/250VAC

Motor Ratings : 120VAC 240VAC

Horsepower : 1/2 1

AC F.L.A. : 9.8 8.0

AC L.R.A. : 58.8 48.0

Pilot Duty Rating : 125 VA/120/240 VAC

Ambient Temperature Range:

32°F/176°F (0°C/80°C)

Media Temperature Range:

32°F/250°F (0°C/121°C)

Pipe Connections:

1" NPT Brass on models IFSxxB

1" NPT 316 Stainless Steel on models IFSxxS

Conduit Entrance: Two openings for 1/2" conduit

Usage: For pipe sizes 1" - 8"

Note: IFSW Series available with NEMA 4 enclosure for outdoor use. (See bulletins #102-026 & #102-027 or Catalog 100-8.2).

⚠ CAUTION

This device is not intended for applications in explosive environments.

MOUNTING AND INSTALLATION

The Model IFS may be mounted in a horizontal pipe line or a vertical pipe line with upward liquid flow. It is not recommended for installations where flow is downward. When mounted in a horizontal pipe line the switch will trip at a lower flow rate than shown in Fig. 7.

Mount the device in a section of pipe where there is a straight run of at least 5 pipe diameters on each side of the flow switch. Do not locate adjacent to valves, elbows or orifices. The switch should be mounted so the terminals or wire leads are easily accessible for wiring.

IFS models with flexible paddles are furnished with 4 paddles. Rigid paddle models are furnished with 2 paddles. For pipe sizes 1", 2", 3" or 6", use the paddles provided. Intermediate sizes may be trimmed from the appropriate paddle using the paddle template in Fig. 5. The paddle must not touch the inside of the pipe or bind in any way. Paddles smaller than the actual pipe size should be used for added support and higher sensitivity, see Fig. 3. The paddles must be properly attached and the screw that holds the paddle must be securely tightened.

For a 1" pipe application mount in a standard 1" x 1" x 1" tee. Use a reducing tee for larger sizes of pipe to keep flow switch close to pipe and provide adequate paddle length in the flow stream.

Example: Use a 2" x 2" x 1" tee for 2" pipe. A weldolet may also be used. Screw the device into the tee fitting as shown in Fig. 4. The flat of the paddle must be at a right angle to the flow. The arrow on the side of the bushing must point in the direction of flow, see Fig. 1.

FIG. 1

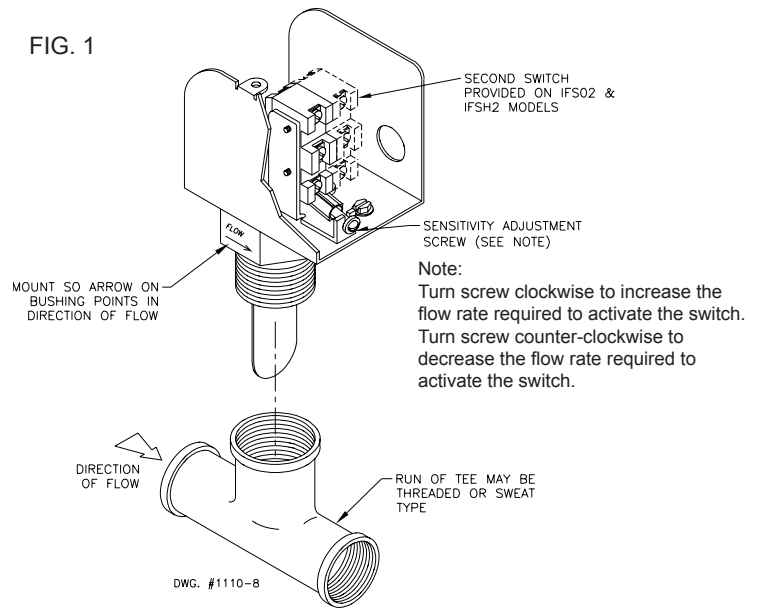

FIG. 2

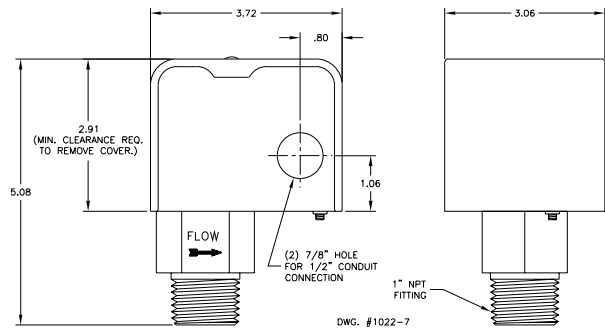

FIG. 3

Typical paddle arrangement for 6" to 8" pipe, using smaller flexible paddles for added support and higher sensitivity.

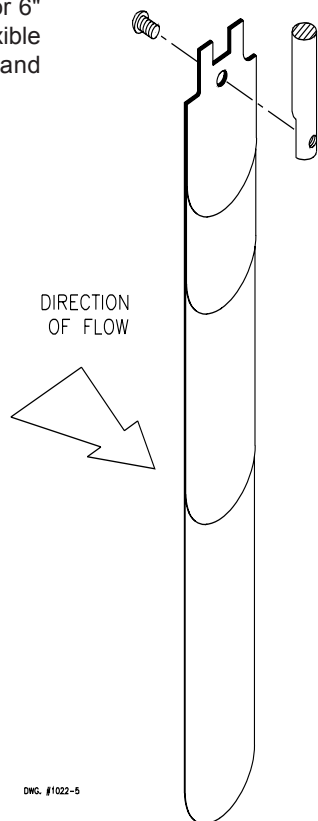
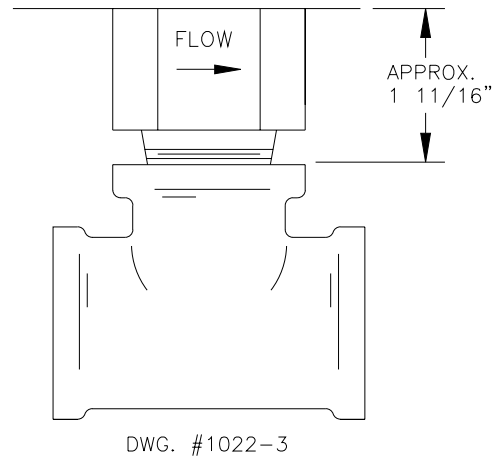

FIG. 4



DWG. #1022-3

CAUTION

Screw the device into the TEE fitting as shown. Care must be taken to properly orient the device for the direction of the flow. Do not tighten by grasping the switch enclosure. Use the wrenching flats on the bushing only. Turning radius required for mounting the IFS is 3".

FIG. 5

Use the drawing as a template and trim at the dotted arc when trimming the appropriate paddle for intermediate pipe sizes.

CAUTION

The paddle must not touch the inside of the pipe or bind in any way.

NOTE:

When installing rigid paddles, do not stack paddles. Only install ONE paddle that best fits the pipe.

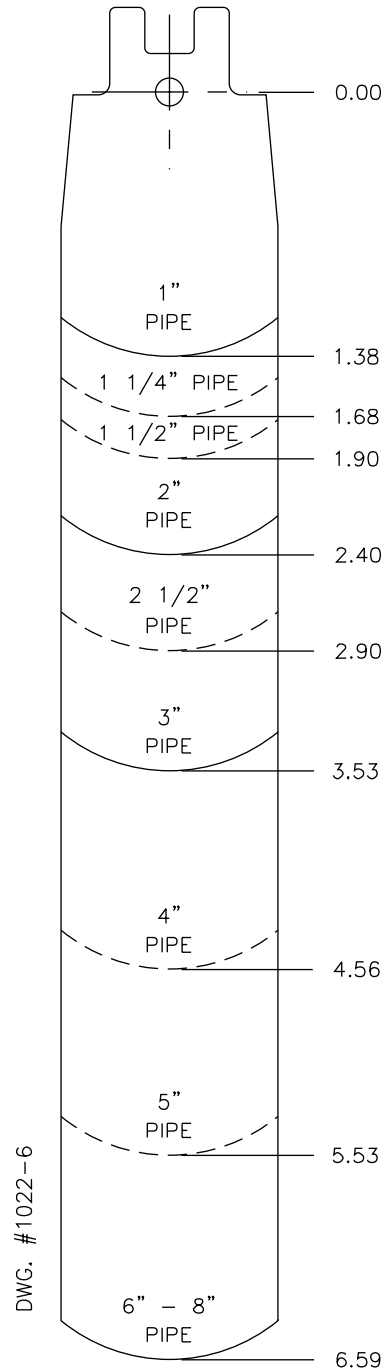

WIRING

Use properly rated temperature supply wire for the anticipated service temperature.

Make all electrical connections in accordance with the National Electrical Code and local regulations.

See Figs. 6A and 6B for diagrams illustrating switch action.

ADJUSTMENT

Remove switch cover and turn the sensitivity adjusting screw clockwise to increase the flow rate required to actuate the switch. Turn the sensitivity adjusting screw counter-clockwise to decrease the flow rate required to actuate the switch. (See Fig. 1.) Be sure to replace the cover upon completion of the installation and adjustment.

CAUTION

Check the installation for "no-flow" switch operation. Make appropriate adjustments to the sensitivity adjustment screw to be sure the switch restores fully at the desired flow rate.

FIG. 6A

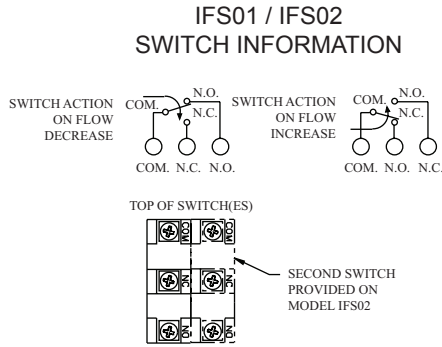

FIG. 6B

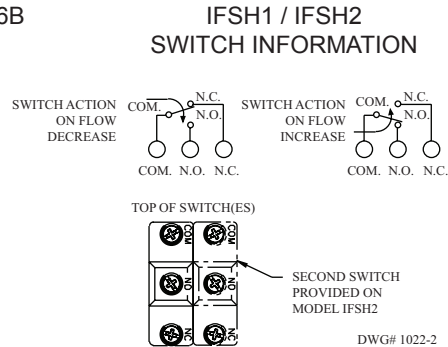

FIG. 7

Typical Flow Rates-GPM Required to Actuate Switch (For Vertical Pipe Installations)											
Pipe Size (Inches)		1	1¼	1½	2	2½	3	4	*5	6	*8
Minimum Adjustment	Flow Increase	4.5	4.5	6	7.5	13.5	18	35	50	70	210
	Flow Decrease	3.5	3.5	5	5.5	9.5	13	25	40	60	190
Maximum Adjustment	Flow Increase	9.5	10	13.5	20	29	50	70	120	180	410
	Flow Decrease	7	8.5	10.5	18.5	26	45	65	105	160	380

NOTES:

1. Typical flow rates for 1" to 1 1/2" pipe sizes are averages which may vary approximately ±1 GPM with the use of a bronze reducing tee.
 2. Typical flow rates for 2" to 8" pipe sizes are averages which may vary ±10% with the use of a 1" weldolet.
- (*) Flow rates for these sizes are calculated.

IFS Ordering

I F S - 1

Process Connection

- F Flexible Paddles
- R Rigid Paddles

Bushing Material

- B Brass
- S 316 Stainless Steel

Model

- 01 Single Switch Model
- 02 Double Switch Model
- H1 High Current Single Switch Model
- H2 High Current Double Switch Model

Paddle Kit Only Ordering

P - 1

Paddle Style

- F Standard Flexible
- R Rigid

CONTROLS MADE EASY™

TACO, INC., 1160 Cranston Street, Cranston, RI 02920 Telephone: (401) 942-8000 FAX: (401) 942-2360.
 TACO (Canada), Ltd., 6180 Ordan Drive, Mississauga, Ontario L5T 2B3. Telephone: 905/564-9422. FAX: 905/564-9436.
 Manufactured by POTTER ELECTRIC SIGNAL CO., St. Louis, MO
 Visit our web site at: <http://www.taco-hvac.com>

Printed in USA
 Copyright 2010
 TACO, Inc.