

DT7235T

DUAL TEC® MOTION SENSOR



The DT7235T DUAL TEC® Motion Sensor provides reliable protection with pet immunity for up to 100 lbs. in a simple installation configuration that requires no adjustments. Optimum performance is achieved using K-Band microwave technology and Uniform Sensitivity Optics.

FEATURES

- **Reliable Detection with 100 lb. Animal Immunity**

By combining Uniform Sensitivity Optics with the advantages offered by K-Band technology, the DT7235T sensor gives installers the best of both worlds — quality detection and the ability to ignore pets or other animals up to 100 lbs.

- **Fast and Simple Installation without Adjustments**

No adjustments are necessary. Installers simply mount the unit at the recommended height, conduct a brief walk-test and the sensor is ready. A highly visible, single colored LED helps the installer easily identify range from any distance or angle within the pattern.

- **Superb Detection through K-Band Technology**

K-Band microwave technology delivers sharp detection without holes or weak spots. The custom-made source offers pattern shaping to fill the protected area with a broad, balloon-shaped pattern which matches the PIR pattern. It also offers

pattern containment to reduce the penetration of microwave energy through walls.

- **Patented False Alarm Prevention Features**

The DT7235T offers more than the standard features that protect against false alarms due to RF signals, electrostatic discharge, and electrical overstress. The patented black bug guard improves white light immunity and the patented adaptive microwave threshold circuit automatically adjusts for room disturbances.

- **Sturdy, Attractive Housing**

The sleek, sturdy housing fits into a variety of building styles and blends with any room decor. ABS plastic is used for shock and impact protection. The housing offers a convenient wiring channel, knockouts for mounting and wiring, and easy access to wiring terminals.

- **Uniform Sensitivity Optics**

The custom-designed Fresnel lens provides the same sensitivity for human targets at the edge of the

pattern as exists directly in front of the sensor, giving the DT7235T consistent coverage throughout the protected area.

- **Microwave Adaptive Threshold**

Using a patented microwave adaption circuit, the DT7235T automatically adjusts its thresholds to account for room disturbances such as ceiling fans and other repetitive moving objects which are not an intrusion event. The result – excellent false alarm immunity even in “active” rooms.

- **White Light Immunity**

A patented black bug guard reduces false alarms by providing 6,500 lux of white light immunity. This helps reduce false alarm problems caused by lights, flashlights or reflective objects.

- **Microwave Supervision**

Independent circuitry supervises the microwave against failure.

DT7235T

DUAL TEC® MOTION SENSOR

SPECIFICATIONS

- **Range**
 - 35' x 40' (11 m x 12 m)
- **Alarm Relay**
 - Energized Form A
 - 500 mA, 30VDC
- **Tamper**
 - (NC) 50 mA, 24VDC
- **Power Requirements**
 - 7.5–16VDC
 - (8.9–14.5VDC for UL installations)
 - 25 mA
 - AC Ripple: 3V peak-to-peak at 12VDC nominal
- **Frequencies**
 - 24.125 GHz (K-Band)
- **PIR White Light Immunity**
 - 6,500 lux typical
- **RFI Immunity**
 - 30 V/m, 10 MHz – 1000 MHz
- **Operating Temperature**
 - 14° to 131° F (-10° to 55° C)
 - 5% – 95% relative humidity non-condensing
- **PIR Fields of View**
 - 22 long range edges
 - 12 intermediate edges
 - Six lower edges
 - Four look-down edges
- **Dimensions**
 - 4.685" x 2.795" x 1.654" (11.9 cm x 7.1 cm x 4.2 cm)
- **Sensitivity**
 - 2-4 steps within field of view

INSTALLATION

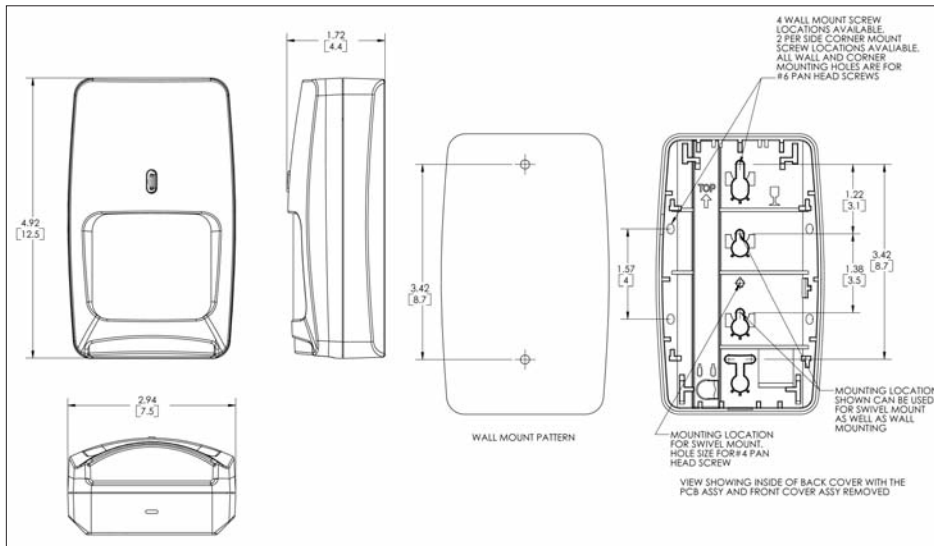

DETECTION PATTERNS

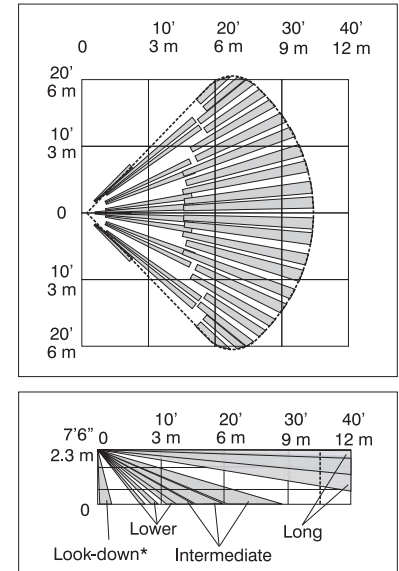

ORDERING

DT7235T DUAL TEC Motion Sensor

Accessories

- DT7000-LRLK** Long Range Lens Kit (10 pack)
- DT7000-HSLK** High Security Lens Kit (10 pack)
- DT7000-PALK** Pet Alley Lens Kit (10 pack)
- 0-000-110-01** SMB10 Universal White Swivel Mount Bracket (5 pack)
- 0-000-155-01** SMB10T Tampered Universal White Swivel Mount Bracket (5 pack)
- 0-000-111-01** SMB10C Universal White Ceiling Mount Bracket (5 pack)



Automation and Control Solutions

Honeywell Security Products Americas
2 Corporate Center Dr. Suite 100
P.O. Box 9040
Melville, NY 11747
1.800.467.5875
www.honeywell.com

L/DT7235TD/D
February 2012
© 2012 Honeywell International Inc.

Honeywell