

MAXPRO® NVR Hybrid SE (Standard Edition)

www.honeywellvideo.com

32-CHANNEL (16 ANALOG INPUTS) HYBRID NETWORK VIDEO RECORDER (NVR)

Honeywell's MAXPRO® NVR Hybrid SE is an open, flexible and scalable Hybrid (IP and analog) video surveillance system. MAXPRO NVR Hybrid SE utilizes Honeywell's HD cameras to offer a powerful high definition IP recording and security monitoring system for small to medium sized installations. It also supports analog cameras, enabling transition by keeping existing analog investment while transitioning to IP. MAXPRO NVR Hybrid SE is an open platform and supports broad third party device integrations with support for PSIA and ONVIF (including Profile S devices) standards, real time streaming protocol (RTSP) standard and native device integrations including 360° camera support.

MAXPRO NVR Hybrid SE provides easy to use desktop clients, web client and mobile apps—MAXPRO Mobile. The Web Client is supported from any standard Mac or PC browser and requires no additional install, provides the value of reduced setup, maintenance and improved compatibility. The interface is simple and intuitive with all the functionality and features that users need for daily surveillance operations, such as live view and playback of recorded video.

MAXPRO NVR Hybrid SE comes pre-installed with all required software and is also pre-licensed for 32 channels. This, along with an easy 3-Click* wizard to live video for auto configuration, makes installing an IP system quick and efficient without requiring any IT expertise. Simple and logical configuration pages make setup a breeze, even for the novice installer.

The MAXPRO NVR Hybrid SE user interface is based on Honeywell's flagship MAXPRO VMS user interface which offers a feature rich user experience and is common across the MAXPRO NVR family. Utilization of this familiar interface allows for the "learn one, know them all" concept that allows for familiarity across a broad range of Honeywell products.

MAXPRO NVR Hybrid SE supports simultaneous recording, search, and system management for 32 channels - any combination of either IP cameras (including high definition formats) or up to 16 analog cameras. Multiple MAXPRO Hybrid NVRs and NVRs can be deployed for system expansion using a distributed architecture and integrated with the MAXPRO Viewer multi-site software or MAXPRO VMS enterprise video management system.

MAXPRO NVR Hybrid SE utilizes powerful processor and memory technology supporting multiple simultaneous operations such as video recording and video viewing or alarm monitoring on the unit itself without the need for an additional workstation. It also supports remote monitoring. End users can view live video while simultaneously performing searches. MAXPRO NVR Hybrid SE offers advanced features. Honeywell's patented Video Surround feature allows for tracking subjects of interest as they move between areas covered by adjacent cameras by simply double-clicking on the panel where the subject is currently visible. Features such as the powerful calendar, preview search options and film strip view allow for rapidly searching video for scenes of interest and then a quick export method transfers video to an authenticated video clip playable through Windows Media player.

*With default settings and in a local area network

Market Opportunities

The continual growth of IP networks and the demand for high definition video have led to the need for convergence of analog security systems and IP systems for many companies across the globe. This has resulted in a strong demand for a Hybrid (IP and analog) end-to-end security system deployment. MAXPRO NVR Hybrid SE provides an open, flexible and scalable system with operational power to address the needs of a wide variety of applications including education, commercial, retail, healthcare and many other applications. When the need is for an easy to install, simple to use, and feature rich hybrid network video recorder, the solution is MAXPRO NVR Hybrid SE.



HD

MAXPRO NVR Hybrid SE



MAXPRO® NVR Hybrid SE

www.honeywellvideo.com

FEATURES

Software

- MAXPRO NVR Hybrid SE allows local or remote operations including live and recorded video monitoring, configuration and system management in a single desktop client interface
- Support for Web Client on Windows PC (Internet Explorer, Chrome and Firefox browsers) and Mac (Safari browser). Supports live, playback/search of recorded video for up to 1080p resolution on all cameras, taking snapshots and viewing presets for PTZ cameras
- Support for mobile monitoring clients on iOS and Android with MAXPRO Mobile apps
- Broad device integrations: Honeywell cameras and encoders, third party devices with support for standards—PSIA and ONVIF (including Profile S devices), RTSP standard and native device integration including 360° camera support
- Feature-rich, user-friendly Windows based interface to view HD and analog video and configure system settings
- Easy 3-click wizard to set up the system with auto-configuration and auto-discovery of IP cameras, recording and monitoring configuration—without any IP video expertise
- Multi-zoom views on HD video. Example: Zoom in on a cash register in one view of the HD camera while at the same time monitoring the cash operator in the zoom out view of the HD camera.
- Ability to investigate events and alarms by simultaneously viewing alarm videos at various stages. For every alarm, users can view the video captured during pre-alarm, on-alarm, and post-alarm, and also view live video from the camera which triggered the alarm.
- Enriched video viewing experience through the intuitive video rendering engine that optimizes CPU utilization by altering the video frame rate
- Honeywell's patented Video Surround feature simplifies the process of tracking subjects through a set of surrounding cameras
- Create, save and name salvos under My Salvos or Shared Salvos
- IP and analog PTZ control and digital zoom on fixed cameras. 360° immersive viewing experience providing heightened situational awareness and increased video surveillance coverage.
- Fast search by date/time, time line, time jump, bookmarks, calendar, preview, film strip view and events. Increase productivity with more efficient search/investigation: Get to the relevant video in few clicks without having to review hours of recordings.
- Event history and operator log reporting with export in .pdf, Crystal Reports, Excel or Word
- Capture and export clips and still images in simple .wmv and .bmp formats. Clips signed with digital signature for authentication
- Supports multiple client connection to NVR Hybrid Server
- Separate event video and general recorded video retention times
- Email notification on camera, system and operator events
- Role-based operator privileges supporting Windows and local users
- Flexible Motion detection (VMD) with Server (Smart VMD) or Camera based motion events support. Reduced false alarms with object based motion detection analytics with Smart VMD.
- Advanced security features with encryption support for communication between desktop client to NVR and secure https login for Web Client
- Keyboard control with UltraKey Plus and UltraKey Lite over Ethernet
- Local and multi-language support
- Multi-site support with MAXPRO Viewer
- Integration with MAXPRO VMS
- Integration with WIN-PAK® and Pro-Watch® Access Control Systems

Hardware

- Record and monitor up to 32 channels with combination of 16 analog with 480 fps @ CIF NTSC (400 fps @ CIF PAL) or 120 fps @ 4CIF NTSC (100 fps @ CIF PAL) and 16 IP with 320 fps @ 1080p HD OR all 32 IP with 960 fps @ 720p HD or 640 fps @ 1080p HD per MAXPRO NVR Hybrid SE. Network bandwidth/throughput supported per NVR Hybrid with Incoming: 120 Mbps, Outgoing: 120 Mbps providing a Total: 240 Mbps.
- Supports One-Way Audio (for specific IP cameras) with live and playback on desktop clients for up to 32 IP channels
- Analog cameras support with 16 looping inputs, 16 IOs and 1 analog PTZ control port on the unit
- Includes HDMI, VGA, DVI-D and Display ports for single monitor support for local client and spot monitor support for analog cameras
- MAXPRO NVR Hybrid SE supports displaying 16 cameras at one time, greater numbers of cameras can be displayed by adding additional client workstations
- 4 removable bays with 1 operating system & storage hard drive and 3 storage only hard drives (optional 1 TB, 2 TB, 3 TB or 4 TB drives). Internal storage capacity from 1 TB to 16 TB.
- Includes dual 1 GB Network ports optimized to separate record and viewing data to ensure 100% recording and smooth playback even with multiple client connections
- 4U rack mount form factor with locking front bezel. Rack ears included for use with four post racking systems.

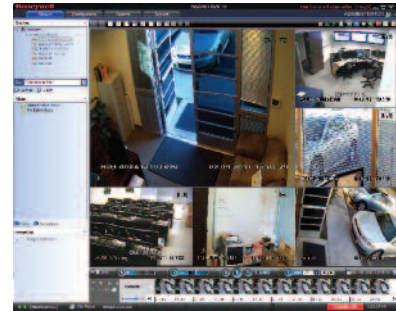

6 Split

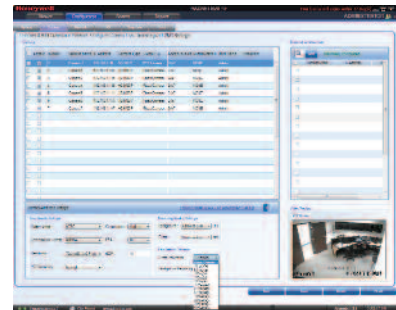

Event Record

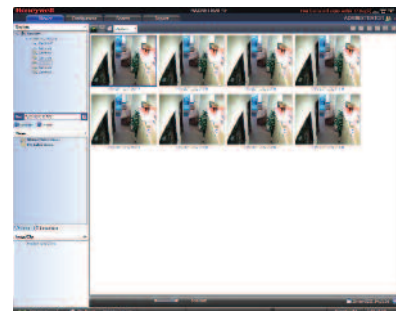

Preview

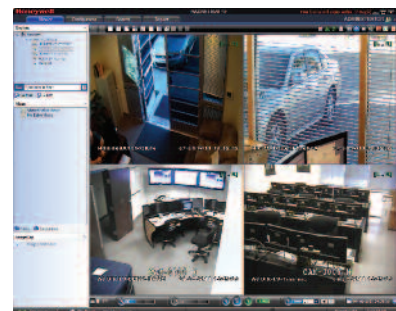

Quad

MAXPRO® NVR Hybrid SE

www.honeywellvideo.com

SYSTEM DIAGRAM

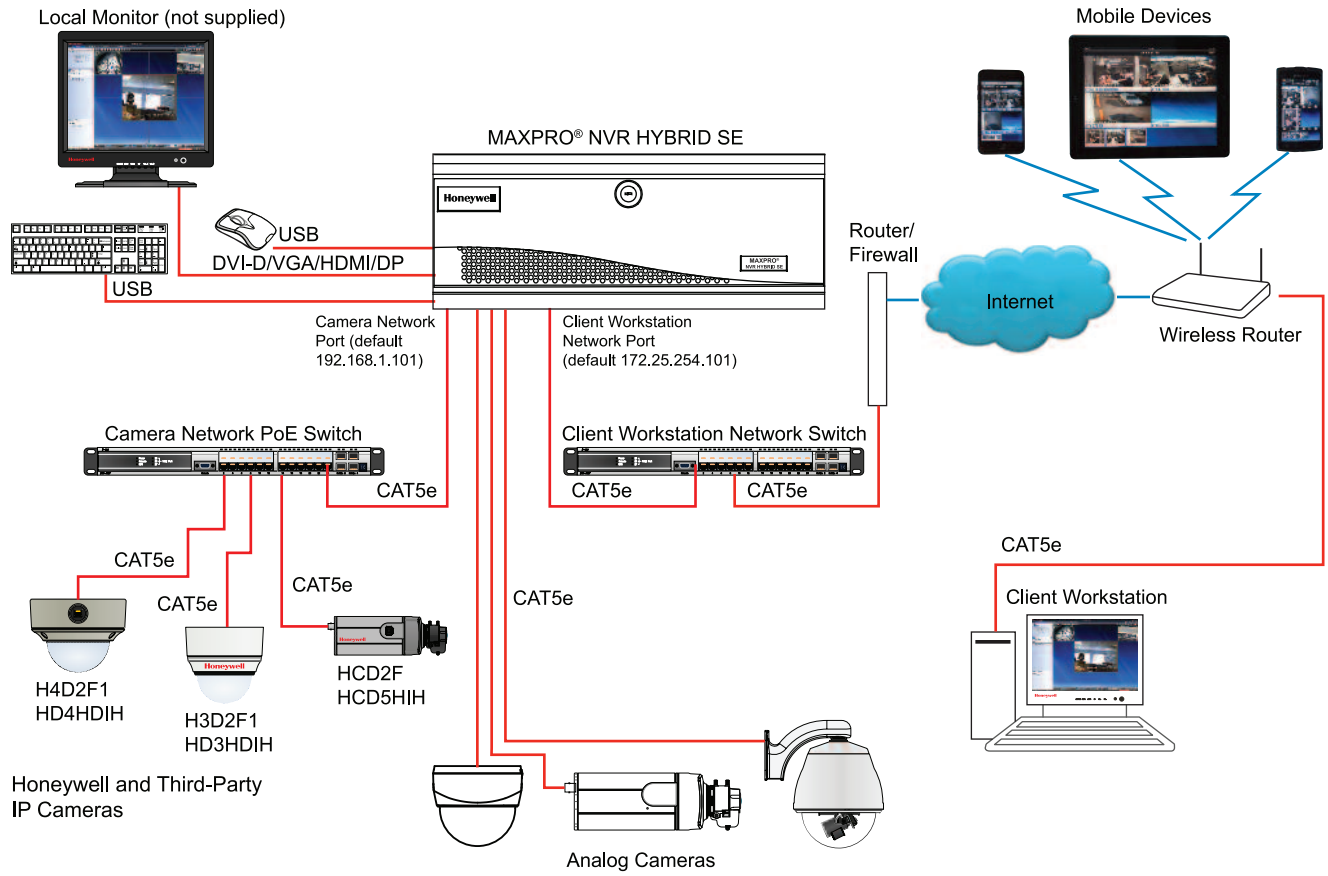

SPECIFICATIONS

Operational	
MAXPRO NVR Hybrid SE Software - Version 3.1 or above	
Database	Microsoft SQL Express 2008 R2
Operating system	Windows Embedded Standard 7 SP1, 64-bit
Image compressions supported	MPEG-4, H.264
Supported Honeywell IP cameras and encoders	Supports Performance Series IP, EQUIP® Series, IP PTZ cameras including high definition. Refer to www.honeywellsecurity.com/hota
Audio Support	1-way audio for specific IP camera models. Refer to www.honeywellsecurity.com/hota
Supported third party IP cameras and encoders	Refer to the Honeywell Open Technology Alliance for a comprehensive list of compatible products to which this device is integrated. www.honeywellsecurity.com/hota
Analog PTZ Protocols Support	MAXPRO, VCL, Pelco P, Pelco D, GE/Kalatel
Maximum number of desktop client connections	18 remote per unit from 9 remote workstations + 1 local on NVR Hybrid server
Salvo layouts	Desktop Client - Full, 2x2, 1x5, 3x3, 2x8, 1x12, 4x4. Web Client - 2x2, 1x1, 1x2, 1x3
Picture controls per camera	Sharpness, blur, brightness, contrast, hue, saturation, maintain aspect ratio, stretched, original size and picture mirror
OSD	Concealed text option
Playback controls per camera	FWD/REV Play x (1, 2, 4, 8, 16) Slow FWD/REV Play x (1/2, 1/4, 1/8)
Search types	Time/date timeline, time jump FWD/REV, bookmarks, calendar, preview, film strip and event search
Recording schedule	Constant and event based with H/M/D and holiday and exception days
Recording methods per camera	Constant, event based and user activated
Live settings per camera	Compression format, resolution and frame rate
Record settings per camera	Same as live or reduced frame rate
Clip format	WMV with digital certificate for authentication playable with Windows media player
Video clip authentication	Digital signature, verification tool provided
Motion detection location	Camera based for supported models or Server based (Smart VMD) for all analog and IP models (except 360 fisheye/panomorph views)
Event recording	Pre and post duration setting
Operator reporting	Per user, configurator, session and viewer
Event report	Per camera or recorder events
Operators	1024

Operational	
MAXPRO NVR Hybrid SE Hardware	
Processor	Intel® Core™ i7-4770 3.4 GHz
Memory	8 GB
Power supply	Single 465 W
OS Partition	100 GB partition in storage drive 1
Storage capacities	1 TB to 16 TB
Storage hard drive options	4 bays - 1 operating system & storage drive, 3 field-upgradable, 1, 2, 3 TB or 4 TB SATA hard drives
Optical	22x DVD-RW
Network	Two 1 GB Ethernet included
Chassis with locking bezel	4U 4 bay
Rear Panel Connections	
Video Input	16 looping, BNC 1 Vp-p @ 75 Ohms
Video Output	MAIN-OUT Single monitor support-1 HDMI, 1 VGA, 1 DVI-D, 1 Display port) and SPOT-OUT (RCA)
Sensor Inputs General Purpose	16, NO/NC - selectable
Control Outputs	16, Relay Output
Serial Ports	2x Front USB, 4x Rear USB, 1xRS485
Network	2x RJ45
Electrical	
Input voltage	115-230 VAC, 50-60 Hz 10/7A
Power consumption	Up to 465 W
Mechanical	
Construction	Housing: Steel chassis Finish: Black matte paint
Dimensions (L x W x H)	21.65" x 17.40" x 7" (550 mm x 442 mm x 180 mm)
Weight	Unit: 64 lb (29 kg) Shipping: 64 lbs (29 kg) to 84 lbs (38 kg)
Environmental	
Temperature	Operating: 5°C to 40°C (40°F to 104°F) Storage: -10°C to 65°C (14°F to 150°F)
Relative Humidity	0% - 90%, non-condensing
Regulatory	
Emissions	FCC Part 15, Subpart B, Class B; EN55022:2010
Safety	ANSI/UL 60950-1; CAN/CSA C22.2 60950-1; EN60950 1:2006+A11:2009+A12:2011 +A1:2010
Immunity	EN50130-4:2011
Warranty	
Warranty and Advanced Replacements	Refer to http://www.honeywellvideo.com/support/warranty/index.html

Recording and Monitoring Performance	16 analog with 480 fps @ CIF NTSC (400 fps @ CIF PAL) or 120 fps @ 4CIF NTSC (100 fps @ 4CIF PAL) and 16 IP with 320 fps @ 1080p HD; OR all 32 IP with 960 fps @ 720p HD or 640 fps @ 1080p HD. 1-way audio for up to 32 IP channels. Network bandwidth/throughput - Incoming: 120 Mbps, Outgoing: 120 Mbps, Total: 240 Mbps
Max Video Streams Support	Web Client: Total Streams Limit - 32 (live + playback). Note: Live streams consumed are per camera being viewed live and duplicate live views of the same camera in multiple or same web client instance are allowed without consuming additional streams. Playback streams consumed are per playback stream being viewed and each playback stream being viewed consumes 1 additional stream. Desktop Client: Live - 160 streams, Playback/Video retrieval sessions - 32, Sync playback - 9 streams.
Server based VMD (Smart VMD) performance - channels supported	Channels at max fps: 32 ch IP at 960 fps @ 4CIF/VGA or 32 ch IP at 960 fps @ 720p or 16 ch IP at 640 fps @ 1080p. 16 analog at 480 fps @ CIF/96 fps @ 4CIF and 16 IP at 320 fps @ 1080p. All Channels at fps: 32 ch IP at 960 fps @ 4CIF/VGA or 960 fps @ 720p or 320 fps @ 1080p. 16 analog at 480 fps @ CIF/96 fps @ 4CIF and 16 IP at 320 fps @ 1080p. Note: Local client - 2x2 view for 1080p and 4x4 view for all other lower resolutions.

MAXPRO® NVR Hybrid SE

www.honeywellvideo.com

SPECIFICATIONS

MAXPRO NVR Hybrid Client Only Workstation – Minimum Specifications	
Processor	Intel® Core™ 2 Duo Processor E6750 2.66 GHz or Quad Core Intel® Xeon® E5405 2.0 GHz
System Memory (RAM)	Minimum 4 GB or Higher
OS & Application – Hard Disk Drive or Partition	Minimum 100 GB Partition drive or separate hard drive
Graphics Adapter	512 MB or higher Display Card for Dual Monitor – DirectX 9 Compatible
Network Interface	Minimum – 1 Gigabit network interface card
Optical Drive	DVD-RW
Monitor Resolution	Video resolution 1280x1024 pixels, 32 bit
Keyboard/Mouse	102-key keyboard and mouse
Operating System Options	Microsoft® Windows 7 Professional SP1 (32-bit and 64-bit), Microsoft® Windows Server 2008 R2 SP1

Note: The minimum specifications above are recommended for systems with fixed or PTZ cameras only. For systems with multiple 360 cameras using full immersive experience with dewarping and playback requires superior workstation specifications than above.

SYSTEM DIMENSIONS

Front View

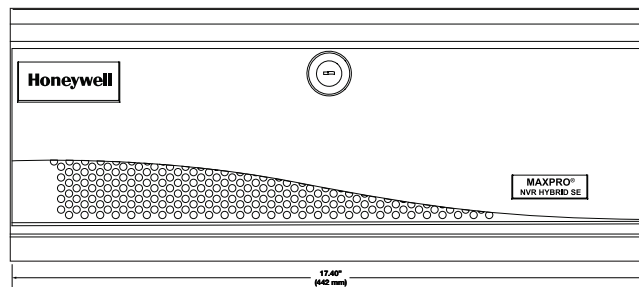

Rear View

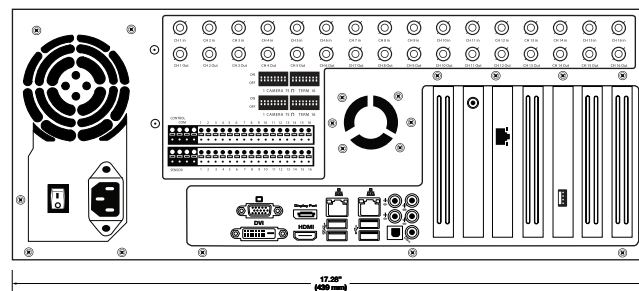

Side View

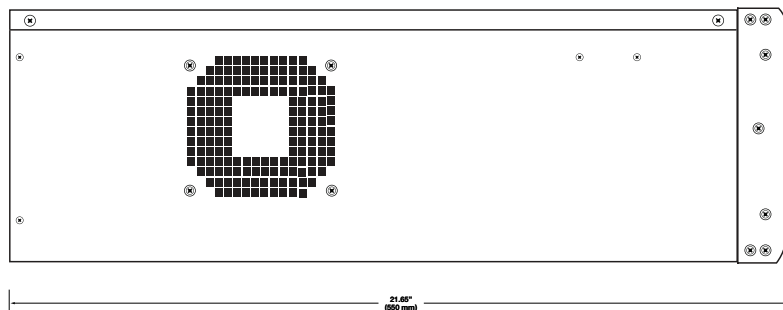

MAXPRO® NVR Hybrid SE

www.honeywellvideo.com

ORDERING

MAXPRO NVR Hybrid SE	
HHSE32C1601T	MAXPRO NVR Hybrid SE, 1 TB, 32 channel (Analog + IP) with 16 Analog @ 480CIF, 1x1 TB HD, 3x spare HD slots
HHSE32C1602T	MAXPRO NVR Hybrid SE, 2 TB, 32 channel (Analog + IP) with 16 Analog @ 480CIF, 1x2 TB HD, 3x spare HD slots
HHSE32C1603T	MAXPRO NVR Hybrid SE, 3 TB, 32 channel (Analog + IP) with 16 Analog @ 480CIF, 1x3 TB HD, 3x spare HD slots
HHSE32C1604T	MAXPRO NVR Hybrid SE, 4 TB, 32 channel (Analog + IP) with 16 Analog @ 480CIF, 1x4 TB HD, 3x spare HD slots
HHSE32C1606T	MAXPRO NVR Hybrid SE, 6 TB, 32 channel (Analog + IP) with 16 Analog @ 480CIF, 2x3 TB HD, 2x spare HD slots
HHSE32C1608T	MAXPRO NVR Hybrid SE, 8 TB, 32 channel (Analog + IP) with 16 Analog @ 480CIF, 2x4 TB HD, 2x spare HD slots
HHSE32C1609T	MAXPRO NVR Hybrid SE, 9 TB, 32 channel (Analog + IP) with 16 Analog @ 480CIF, 3x3 TB HD, 1x spare HD slots
HHSE32C1612T	MAXPRO NVR Hybrid SE, 12 TB, 32 channel (Analog + IP) with 16 Analog @ 480CIF, 4x3 TB HD
HHSE32C1616T	MAXPRO NVR Hybrid SE, 16 TB, 32 channel (Analog + IP) with 16 Analog @ 480CIF, 4x4 TB HD

Accessories	
HHSECHD1T	1 TB Upgrade Kit, MAXPRO NVR Hybrid SE
HHSECHD2T	2 TB Upgrade Kit, MAXPRO NVR Hybrid SE
HHSECHD3T	3 TB Upgrade Kit, MAXPRO NVR Hybrid SE
HHSECHD4T	4 TB Upgrade Kit, MAXPRO NVR Hybrid SE

Refer to the storage calculator on www.honeywellvideo.com to help determine what size unit to order.

NOTE: Honeywell reserves the right, without notification, to make changes in product design or specifications.

MAXPRO NVR Hybrid SE - Part Number Lookup

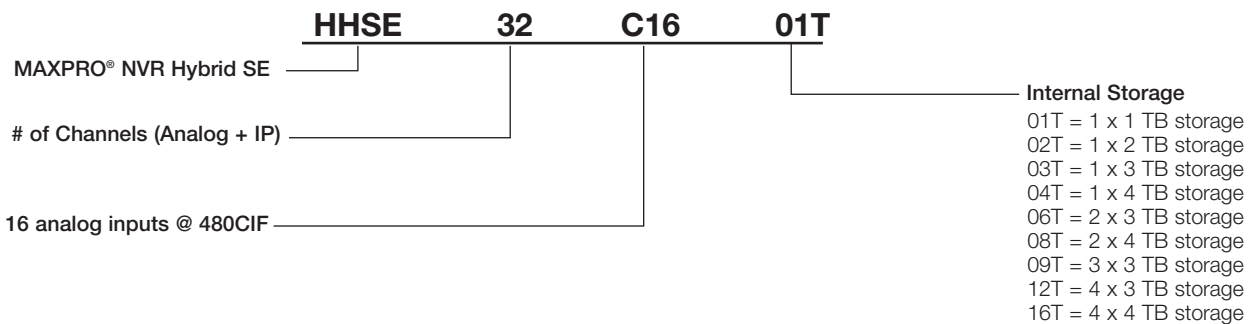

For more information:

www.honeywell.com/security

Automation and Control Solutions

Honeywell Security Products Americas
 2700 Blankenbaker Pkwy, Suite 150
 Louisville, KY 40299
 1.800.323.4576
www.honeywell.com

