

# 1080p TWDR IR MFZ Ball Camera

HD231HD2

Supercharge your analog security system with Honeywell's HQA technology for high definition 1080p images over your existing coax infrastructure. The Performance Series HQA line includes a wide range of high performing IR cameras that are easy to install and even easier to use.

## Superior Image Quality

- Full HD 1080p 25/30 fps image with a 1/2.7" 2.1 MP sensor
- True Wide Dynamic Range, up to 120 dB, ensures glare-free images
- Long distance transmission over coaxial cable with low attenuation and latency—up to 984 ft (300 m) using RG-59/U
- True Day/Night provides vivid color images by day and clear black-and-white images at night with ICR
- True Wide Dynamic Range (120 dB)
- Excellent low-light performance with 3D noise reduction

## Flexible Surveillance Solution

- 2.7–12 mm motorized focus/zoom lens at F1.4
- IR LEDs provide up to 200 ft (60 m) of illumination in dimly lit or nighttime scenes (depending on scene reflectance)
- Smart IR technology provides even distribution of IR
- Weatherproof (IP66) camera housing
- -22°F to 140°F (-30°C to 60°C) working temperature
- Plug-and-play compatible with Honeywell 4/8/16-channel Performance Series HQA DVRs

## Easy to Install and Use

- 12 VDC/24 V AC power input
- Uses existing BNC cabling—no rewiring required
- Remote configuration through web client or from the DVR

These flexible, fully featured cameras are ideal for a wide range of surveillance applications, providing excellent picture quality at an affordable price.



HD231HD2

## FEATURES AND BENEFITS

- |                                  |   |  |   |                                 |
|----------------------------------|---|--|---|---------------------------------|
| • 1/2.7" 2.1 MP imager           | • True WDR (120 dB)   | • Up to 200 ft (60 m) of IR illumination, depending on scene reflectance | • HQA/CVBS video output                       | • 12 VDC or 24 V AC power input |
| • 2.7–12 mm MFZ lens             | • Low-light performance down to 0.03 lux (color) or 0 lux with IR LEDs on |  | • Transmission distances up to 984 ft (300 m) | • IP66-rated housing            |
| • True day/night (IR-cut filter) |   |  |   |                                 |

# 1080p TWDR IR MFZ Ball Camera

## SPECIFICATIONS

OPERATIONAL		MECHANICAL	
IMAGE SENSOR	1/2.7" 2.1 MP CMOS	DIMENSIONS	4.8 × 4.0 in. (122.0 × 102.0 mm)
NUMBER OF PIXELS (H×V)	1928×1088	WEIGHT	1.21 lb (0.55 kg)
ELECTRONIC SHUTTER SPEED	1/3–1/30 000 s	CONSTRUCTION	Die-cast aluminum
MINIMUM ILLUMINATION	0.03 lux @ F1.4 (color) 0 lux (B/W with IR LEDs on)	COLOR	RAL 7022 (Gray)
S/N RATIO	50 dB or more	ENVIRONMENTAL	
RESOLUTION	25/30/50/60 fps @ 720p; 25/30 fps @ 1080p	TEMPERATURE	–22°F to 140°F (–30°C to 60°C)
VIDEO OUTPUT	1-channel HQA BNC cable; 1-channel CVBS BNC cable	RELATIVE HUMIDITY	0–95%, non-condensing
IR DISTANCE	Up to 200 ft (60 m)	INGRESS PROTECTION	IP66
DAY/NIGHT	Auto (ICR)/Color/BW	REGULATORY	
BLC	120 dB True WDR	EMISSIONS	FCC Part 15, CE (EN 55032)
NOISE REDUCTION	2D/3D	IMMUNITY	CE (EN 50130-4)
LENS	2.7–12 mm, MFZ, F1.4	SYSTEM COMPATIBILITY	
HORIZONTAL ANGLE OF VIEW	99°–37°	HRHM	H.264 4Ch 1080p HQA DVR
MOUNT TYPE	Φ14	HRHH	H.264 4/8/16Ch 1080p HQA DVR
ELECTRICAL		MOUNTS	
POWER SUPPLY	12 VDC/24 VAC ±25%	WALL MOUNT	HQA-WK
POWER CONSUMPTION	12.0 W max.	JUNCTION BOX	HQA-BB2, HEJB, HBS2-BB
		POLE MOUNT	HQA-PM, HQA-PM2
		CORNER MOUNT	HB34S2-CM

## DIMENSIONS

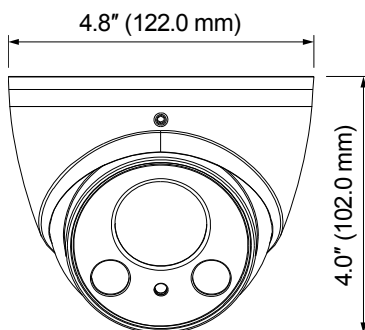

## ORDERING

HD231HD2 | TWDR IR Ball Camera, 1/2.7" CMOS, 1080p, 2.7–12 mm MFZ, 2 High Power IR LEDs, 12 VDC/24 VAC

### For more information

[www.honeywell.com/security](http://www.honeywell.com/security)

### Honeywell Security and Fire

2700 Blankenbaker Pkwy, Suite 150  
Louisville, KY 40299  
1.800.323.4576  
[www.honeywell.com](http://www.honeywell.com)

NOTE: Honeywell reserves the right, without notification, to make changes in product design or specifications.

L/1080PTBD/D | 04/17  
© 2017 Honeywell International Inc.

**Honeywell**