



Installation and Maintenance Instructions for H355, H355R, and H355HT Intelligent Plug-In Temperature Sensors

This sensor must be installed in compliance with the control panel system installation manual. The installation must meet the requirements of the Authority Having Jurisdiction (AHJ). Sensors offer maximum performance when installed in compliance with the National Fire Protection Association (NFPA); see NFPA 72.

Before installing sensors, please read the system wiring and installation manual thoroughly. This manual provides detailed information on sensor spacing, placement, zoning, and special applications. Copies of these manuals are available from Fire•Lite.

GENERAL DESCRIPTION

Models H355, H355R, and H355HT are intelligent sensors that utilize a state-of-the-art thermistor sensing circuit for fast response. These sensors are designed to provide open area protection with 50 foot spacing capability. Model H355 is a fixed temperature sensor with 135° F fixed temperature alarm. Model H355R is a rate-of-rise temperature sensor with 135° F fixed temperature alarm. Model H355HT is a high temperature sensor with 190° F fixed temperature alarm.

Two LEDs on each sensor light to provide a local, visible sensor indication. Remote LED annunciator capability is available as an optional accessory (Part No. RA400Z).

Models H355, H355R, and H355HT require compatible addressable communications to function properly. Connect these sensors to listed-compatible control panels only.

SPECIFICATIONS

Diameter:	6.1 inches (155 mm) installed in B350LP
Height:	2.1 inches (51 mm)
Weight:	4.8 ounces (137 gm)
Installation Temperature:	-4°F to 100°F (-20°C to 38°C); H355 and H355R -4°F to 150°F (-20°C to 66°C); H355HT
Operating Humidity Range:	10% to 93% Relative Humidity Noncondensing
Mounting:	B350LP flanged base
Voltage Range:	15 to 32 Volts DC Peak
Standby Current:	300 μ A @ 24 VDC (one communication every 5 sec. with LED blink enabled)
LED Current:	6.5 mA @ 24 VDC
Fixed Temperature Rating:	135°F (57°C); H355 and H355R 190°F (88°C); H355HT
Rate of Rise Detection:	Responds to greater than 15°F/min.; H355R

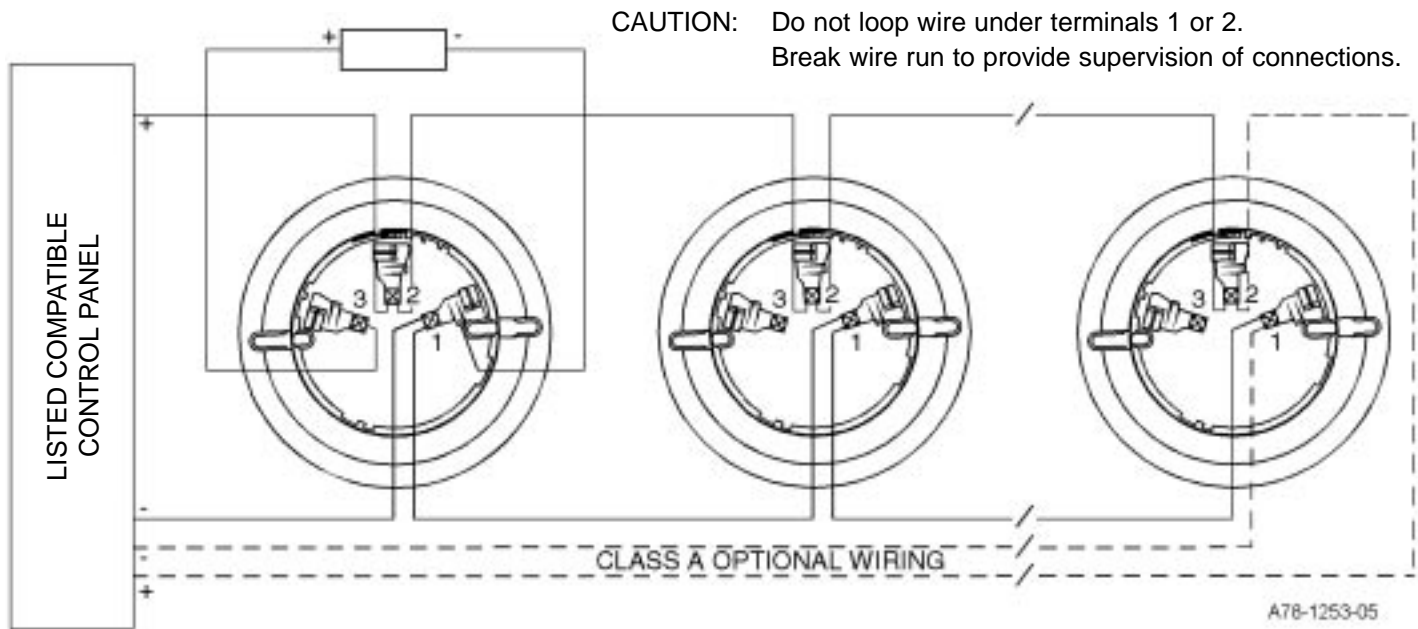

Figure 1

WIRING GUIDE

All wiring must be installed in compliance with the National Electrical Code, applicable local codes and the Authority Having Jurisdiction. Proper wire gauges should be used. The installation wires should be color coded to limit wiring mistakes and ease system troubleshooting. Improper connections will prevent a system from responding properly in the event of a fire.

Remove power from the communication line before installing sensors.

1. Wire the sensor base (supplied separately) per the wiring diagram, see Figure 1.
2. Set the desired address on the sensor address switches, see Figure 2.
3. Install the sensor into the sensor base. Push the sensor into the base while turning it clockwise to secure it in place.
4. After all sensors have been installed, apply power to the control unit and activate the communication line.
5. Test the sensor(s) as described in the TESTING section of this manual.

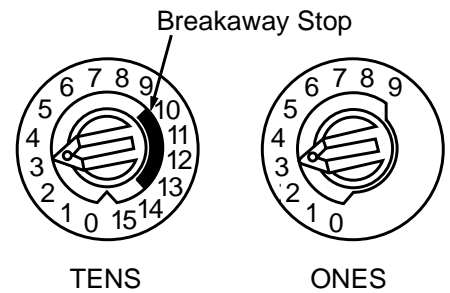

Figure 2

A78-2745-00

TAMPER RESISTANCE

The sensor base includes a tamper proof feature which when activated prevents removal of the sensor without the use of a tool. See the installation instruction manual for the sensor base for details in using this feature.

TESTING SENSITIVITY

Before testing, notify the proper authorities that the system is undergoing maintenance, and will temporarily be out of service. Disable the system to prevent unwanted alarms.

All sensors must be tested after installation and periodically thereafter. Testing methods must satisfy the Authority Having Jurisdiction (AHJ). Sensors offer maximum performance when tested and maintained in compliance with NFPA 72.

- A. Test Magnet (p/n M02-04-01 or M02-09-00)
 1. Place the optional test magnet against the cover in the magnet test area, as shown in Figure 3, to activate the test feature.
 2. The LEDs should latch on within 10 seconds, indicating alarm and annunciating the panel.
 3. Reset the detector at the system control panel.

B. Direct Heat Method (Hair dryer of 1000 – 1500 watts)

1. From the side of the detector, direct the heat toward the sensor. Hold the heat source about 6 inches (15 cm) away to prevent damage to the cover during testing.
2. The LEDs on the detector should light when the temperature at the detector reaches the alarm setpoint. If the LEDs fail to light, check the power to the detector and the wiring in the detector base.
3. Reset the detector at the system control panel.

Detectors that fail these tests should be cleaned as described under MAINTENANCE and retested. If the detectors still fail these tests, they should be returned for repair.

Figure 3. Views showing position of test magnet.

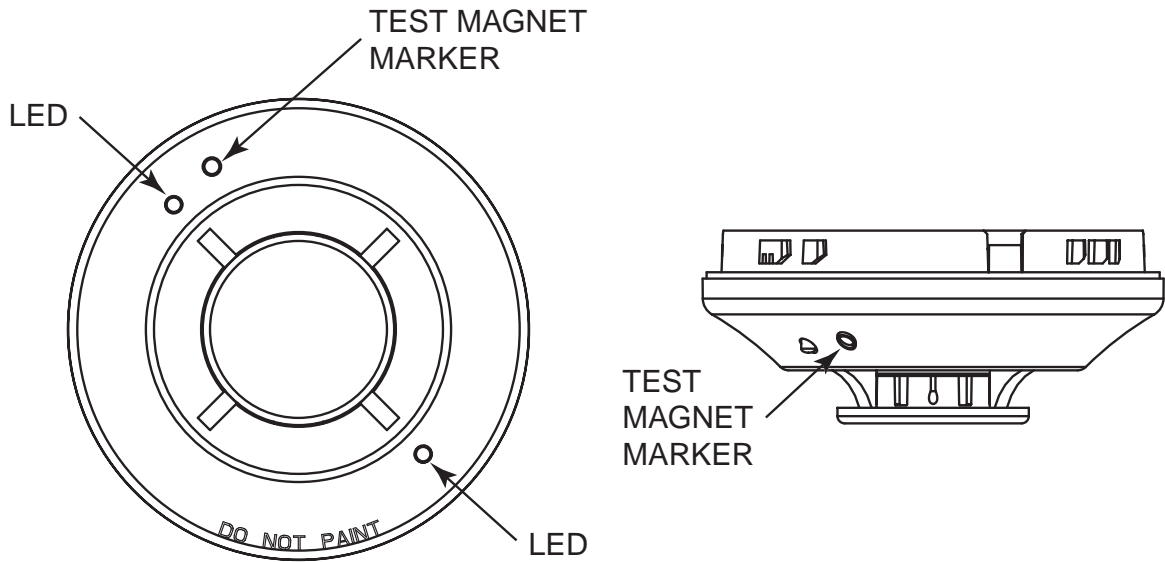

A78-1478-06

MAINTENANCE

NOTE: Before cleaning notify the proper authorities that the system is undergoing maintenance, and therefore the system will temporarily be out of service. Disable the loop or system undergoing maintenance to prevent unwanted alarms.

It is recommended that the sensor be removed from its mounting base for easier cleaning and that sensors be cleaned at least once a year. Use a vacuum cleaner to remove dust from the sensing chamber.

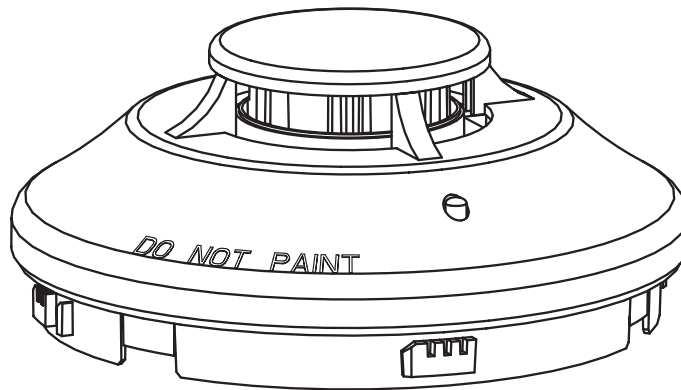

A78-1944-02

Figure 4

Please refer to insert for the Limitations of Fire Alarm Systems

FCC Statement

This device complies with part 15 of the FCC Rules. Operation is subject to the following two conditions: (1) This device may not cause harmful interference, and (2) this device must accept any interference received, including interference that may cause undesired operation.

Note: This equipment has been tested and found to comply with the limits for a Class B digital device, pursuant to Part 15 of the FCC Rules. These limits are designed to provide reasonable protection against harmful interference in a residential installation. This equipment generates, uses and can radiate radio frequency energy and, if not installed and used in accordance with the instructions, may cause harmful interference to radio communications. However, there is no guarantee that interference will not occur in a particular installation. If this equipment does cause harmful interference to radio or television reception, which can be determined by turning the equipment off and on, the user is encouraged to try to correct the interference by one or more of the following measures:

- Reorient or relocate the receiving antenna.
- Increase the separation between the equipment and receiver.
- Connect the equipment into an outlet on a circuit different from that to which the receiver is connected.
- Consult the dealer or an experienced radio/TV technician for help.