

* Try these other fine ELK products *

Magic Module Series

- MM443** MagicModule, 4 Input, 4 Output, Programmable
- MM447** Automation Controller w/Voice, Caddx Interface
- MV480** Recordable Voice Module, 400 Channels
- MKHOME1** Home Control Kit for Caddx NX Controls
- MK400** Starter Kit, Includes MM443 & MK485
- MK485** Programming Kit, MB485, Cables, Software
- MK410** X-10® Transceiver Kit, Programmed MM443
- MK420** iButton™ Access Kit w/ MM443, MA100, MA101
- MA100** iButton™ 'Touchkey' Reader & Interface Pack
- MA101** iButton™ 'Touchkeys', 10 pcs w/keyring holders
- MA290** Proximity / Wiegand Data Interface to MM443
- MB485** Data Bus Interface, RS232 to RS485
- MC100** Clock / Calendar Module for MM443
- ML8** Link Interface to Caddx NX Controls
- MT100** Temperature Sensor Module for MM443
- MM220** MagicModule, 2 Input, 2 Output, Programmable

Rust Free Sirens / Speakers

- 1RT** Speaker & Stainless Steel Enclosure
- 150RT** Siren & Stainless Steel Enclosure
- 155RT** Voice Siren in Stainless Steel Box

Speakers & Sirens

- 44** Speaker, 30 W, 8 Ohm Compact Horn
- 45** Siren, Compact Horn, 118db
- 55** Voice Siren, Compact Horn
- M120** Siren, Single Tone, 107db, Mini Horn
- SP15** Speaker, 15 watt, Small Horn
- SP30** Speaker, 30 watt, Horn
- SP35** Speaker, 20 watt, Interior
- SP40** Speaker, 40 watt, Horn
- SS15** Siren, Dual Tone, 110db, Horn
- SS30** Siren, Dual Tone, 120db, Horn
- SS36** Siren, Dual Tone, 105db, Interior

ECHO™ Sirens & Speakers

- 73** ECHOSpeaker, 20 Watt, Interior
- 74** ECHO Dual Tone Siren, Interior
- 75** ECHO Voice Siren, Interior
- 870** ECHO Speaker, Self Amplified

Siren & Voice Drivers

- 100** High Performance Siren Driver
- 110** Voice Siren Driver, English & Spanish
- 120** Recordable Voice Module and Siren
- 124** Recordable Voice Module, 4 Channels

Surge Suppressors

- 950** Surge Suppressor, Phone & Power Line
- 951** Surge Suppressor, Phone - Single Line
- 955** Surge Suppressor, Phone - Dual Line

Relay Modules

- 912** Compact Relay, 12 Vdc, SPDT
- 912B** Heavy Duty Compact Relay, 12/24 Vdc, SPDT
- 924** Sensitive Relay, 12/24 Vdc, DPDT
- 941** Alarm Output Director
- 960** Delay Timer Relay, 1 sec. to 60 min.

Power Products

- 1240** Battery, Lead Acid, 12v, 5Ah
- 1270** Battery, Lead Acid, 12v, 8Ah
- 12100** Battery, Lead Acid, 12v, 12Ah
- 12170** Battery, Lead Acid, 12v, 18Ah
- 12250** Battery, Lead Acid, 12v, 25Ah
- P112** 12 Volts DC, 1 Amp Power Supply w/Enclosure
- P124** 24 Volts DC, 800mA Power Supply w/Enclosure
- P1216** 12 Volts DC, 1.5 Amp Power Supply
- P412** 12 Volts DC, 4 Amp Power Supply
- P624** Power Supply & Battery Charger
- PD9** Power Distribution Module
- 965** Low Battery Cutoff and Power Switch
- TRG1640** Transformer, 16.5VAC @ 40 VA
- TRG2440** Transformer, 24VAC @ 40 VA

Accessories

- 129** Computer Sound Card Interface
- 800** Audio Amplifier, 10 Watts
- 900-2** "B" Connectors, Unfilled, 500 pcs
- 902-2** "B" Connectors, Gel filled, 500 pcs
- 980** Telephone Line Fault Monitor
- 998** Warning Alarm System Decals
- 999** Double Sided Tape
- SL1** Strobe Light, 4 colors available
- WK1** Wall Mount Kit for SL1 Strobes

For more information contact your local Distributor or:
ELK PRODUCTS, INC 828-397-4200 FAX 828-397-4415
<http://www.elkproducts.com> Email: info@elkproducts.com
05/02

Alarm Output Director ELK-941

APPLICATION:

The **ELK-941** separates the steady or pulsing voltage from a single alarm output and directs this into two (2) different relay outputs. An optional jumper configures Relay 2 to pulse in a temporal-code pattern which meets **ANSI Standard S3.41**. The input trigger can be either positive or negative (pull to ground).



Alarm Output Director ELK-941



FEATURES

- Separates Steady and Pulsing Voltage From a Single Alarm Output and Directs This Into Two (2) Different Relay Outputs.
- Positive or Neg. Low Current Trigger.
- Two (2) SPDT Relay Outputs.
- Ideal For Two (2) Channel Long Range Radio or Cellular Transmitters.
- Option For Temporal Pulse On Relay 2.
- Low Current Output During Delay Time.
- LED Indication of Relay Status.

SPECIFICATIONS

- Operating Voltage: 12 Volts D.C.
- Input Trigger Voltage: 9 - 14 Volts D.C.
- Input Trigger Current: 15 mA.
- Max. Current: 96mA (both relays on).
- Relay Contact Rating: 7A @ 30Vdc.
- Valid Pulse Width: .1 - 4 sec. (.125-5Hz).
- Size: 4.4" x 3" x 1.15".
- Meets ANSI S3.41 *Audible Emergency Evacuation Signals* 3-Pulse Pattern.

Features and Specifications subject to change without notice.



828-397-4200 Voice
828-397-4415 Fax
<http://www.elkproducts.com>
email: info@elkproducts.com
PO Box 100 • Hwy. 70W • Hildebran, NC 28637 • USA

Instructions Printed On Inside

OVERVIEW

The **ELK-941** separates the steady and pulsing voltage from a single alarm output and directs this into two (2) different relay outputs. Steady and pulsing voltage logic is available from most controls that provide only a single alarm output. The relays on the **ELK-941** are activated according to the trigger input, following a 3 to 4 second verification time delay. Relay 1 will activate if a steady input is verified, or Relay 2 will activate if a pulsing input is verified.

INPUT CONNECTIONS

- [+12V] Connect to the positive (+) side of a 12 Volts D.C. power source. Nominal operating range is 9 to 14 Volts D.C.
- [- GND] Connect to the negative (-) side of a 12 Volts D.C. power source.
- [TRG] A positive 9 to 14 Volts D.C. input or a neg. (pull to ground) to this terminal will activate the **ELK-941**. **The polarity of the trigger voltage must be selected using jumper J3.** The input trigger can be from a control panel's single alarm output, or from another source such as an automation controller/timer, a simple pushbutton switch, etc.

OUTPUT CONNECTIONS

- [-P] "Pre-activation" Output (30mA MAX). This is active immediately following the application of a trigger input for 3 to 4 seconds while the **ELK-941** verifies whether the input is steady or pulsing. **Upon determination of steady or pulse, the appropriate relay will activate and this output will cease.** Note: If the trigger input is pulsing, this output will also pulse.
- [NO] Relay 1 Normally Open contact. This terminal is connected with the COM terminal whenever the relay is ON (activated).
- [COM] Relay 1 Common contact. This "pole" or switching part of the relay is connected to the N/O terminal when the relay is ON (activated), and to the N/C terminal when the relay is OFF (at rest).
- [NC] Relay 1 Normally Closed contact. This terminal is connected with the COM terminal whenever the relay is OFF (at rest).
- [NO] Relay 2 Normally Open contact. This terminal is connected with the COM terminal whenever the relay is ON (activated).
- [COM] Relay 2 Common contact. This "pole" or switching part of the relay is connected to the N/O terminal when the relay is ON (activated), and to the N/C terminal when the relay is OFF (at rest).
- [NC] Relay 2 Normally Closed contact. This terminal is connected with the COM terminal whenever the relay is OFF (at rest).

Optional Jumper Descriptions

J1 RELAY MODE

TEMPORAL: In the TEMPORAL position, Relay 2 will be switched on and off in a 3 pulse pattern (3 half-second pulses followed by a 1-1/2 second pause) whenever a pulsing input is detected. This setting has no effect on Relay 1 (it will always be steady).

STEADY: In the STEADY mode, Relay 2 will be steady (solid) when a pulsing input is detected.

IMPORTANT NOTE: With Jumper **J1** in the STEADY position, the **ELK-941** will provide **dual mode latch**, whereby if a steady input activation is followed by a pulsing input or visa-versa, both relays will activate and stay on until the trigger input is completely removed. If the **ELK-941** is used to activate a long range radio or other communications device, this feature prevents restoral signals from being transmitted until both conditions are resolved.

J2 IMMEDIATE OUTPUT

When an input trigger is first applied, the **ELK-941** requires a 3 to 4 second verification time delay to determine if the input is steady or pulsing. If a siren is connected, it may be desirable to immediately activate one of the relays during this delay time. Such uses include closing ring-back, siren test upon arming, etc. Jumper **J2** selects which relay will activate (if any) during this time. If Relay 1 or 2 is selected for immediate output, the selected relay will "follow" the trigger. ie: If the trigger is steady, the relay will be steady. If the input is pulsing, the relay will pulse. Once the **ELK-941** has verified what type of input is being applied, the appropriate relay will then be activated (which may or may not be the same relay that was selected for immediate output).

RELAY 1: With the jumper in this position Relay 1 will turn on during the verification time delay.

RELAY 2: With the jumper in this position Relay 2 will turn on during the verification time delay.

OFF: With the jumper in this position neither Relay will turn on during the verification time delay.

Note: The **-P** terminal can be used to trigger a piezo or other low current device for audible or visual needs. If the trigger input is pulsing, this output will also pulse. The position of jumper **J2** has no effect on the **-P** terminal.

J3 TRG (Trigger Polarity)

This jumper bar is used to set the proper input trigger polarity.

+ Set **J3** to "+" if the ELK-941 will be triggered by a positive voltage input.

- Set **J3** to "-" if the ELK-941 will be triggered by a negative (pull to ground).

APPLICATIONS AND WIRING DIAGRAMS

Long-Range Radio or Cellular Transmitter Interface

Jumper Settings

- J1 = STEADY** - Output of Relay 2 is steady. If both a steady and pulsing input is detected, the dual-mode latch keeps both relays on until input trigger is removed.
- J2 = OFF** - No Immediate Alarm output from either relay.
- J3 = +/-** - Depends on polarity of control's alarm output.

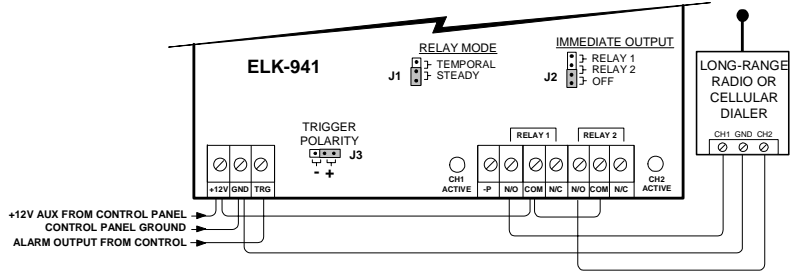

As shown, this hookup is used to activate two channels on a long-range radio or cellular transmitter. Relay 1 activates on steady input; Relay 2 activates on pulsing input. Both relays will stay on until trigger input is removed if both a steady and pulsing input is detected. (Dual mode latch)

Siren and Strobe Light activation from negative polarity alarm output

Strobe light will only activate if alarm output is pulsing

Jumper Settings

- J1 = STEADY** - Output of Relay 2 is steady. If both a steady and pulsing input is detected, the dual mode latch keeps both relays on until input trigger is removed.
- J2 = OFF** - No Immediate Alarm output on either channel.
- J3 = "-"** - Negative polarity alarm output (DSC type control).

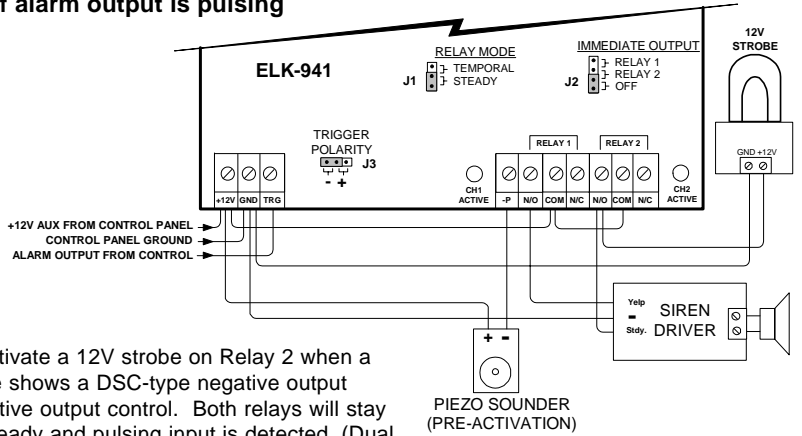

As shown, this hookup is used to activate a 12V strobe on Relay 2 when a pulsing output is detected. Example shows a DSC-type negative output control. Set **J3** to "+" if using a positive output control. Both relays will stay on until input is removed if both a steady and pulsing input is detected. (Dual mode latch) Note: The 12V Aux output must be capable of supplying enough current to drive the strobe and the siren driver.

Temporal coded bell from pulsing alarm output, Siren activation if alarm output is steady

Jumper Settings

- J1 = TEMPORAL** - Output of Relay 2 will be Temporal 3 pulse pattern.
- J2 = OFF** - No Immediate Alarm output on either channel.
- J3 = +/-** - Depends on polarity of control's alarm output.

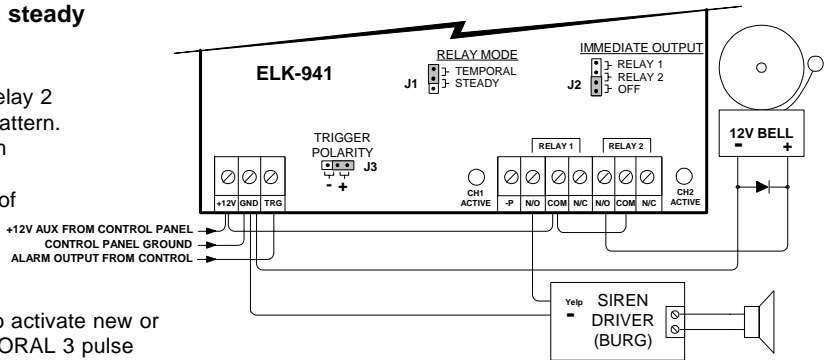

As shown, this hookup is used to activate new or existing Bells in the ANSI TEMPORAL 3 pulse pattern from a pulsing alarm output and a standard siren from a steady alarm output.

Elk-100 Siren Yelp sound from steady alarm output, Temporal coded sound if alarm output is pulsing

Jumper Settings

- J1 = TEMPORAL** - Output of Relay 2 will be Temporal 3 pulse pattern.
- J2 = RELAY 2** - Relay 2 will activate immediately upon trigger input and during the 3 to 4 second verification time delay.
- J3 = +/-** - Depends on polarity of control's alarm output.

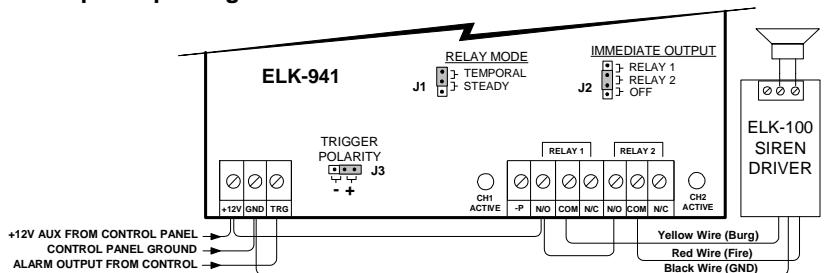

As shown, this hookup is used to activate an ELK-100 siren Yelp sound on Relay 1 from a steady alarm output and a Temporal 3 pulse sound on Relay 2 from a pulsing alarm output. Relay 2 will also activate immediately during the 3 to 4 second verification time delay (regardless of a steady or pulsing input trigger). This immediate output feature is good if the control does a siren test at arm or disarm time.