

# EX65 Explosion Protected Camera

www.boschsecurity.com



**BOSCH**

Invented for life



- ▶ Electropolished 316L stainless steel or aluminum construction
- ▶ High-resolution, high-sensitivity Dinion 2X imager with WDR
- ▶ Integrated junction box
- ▶ ATEX, UL, IECEx, and INMETRO Certifications
- ▶ Sunshield included

The EX65 Explosion Protected Camera is a high-performance, smart surveillance camera for explosive environments. Utilizing Dinion 2X imaging, the camera offers unrivaled image quality in the worst lighting conditions. Electropolished 316L stainless steel construction ensures the ultimate environmental protection available today.

A single pre-assembled unit with an integrated junction box, the EX65 is designed to be easy to install. Through any of the four 3/4-in. conduit entries (M20 adapter also included), connections are made to the convenient terminal block; there is also space for any additional wiring. Also accessible through the junction box is the optional fiber optic module that provides versatility for longer cable runs or where electromagnetic interference is a concern.

When choosing an imaging device for critical applications, you need the confidence that you will receive the best in performance. Dinion 2X delivers! The 20-bit image processing enhances sensitivity; the 2X Dynamic extends the dynamic range. This unique combination provides a sharper, more detailed image with outstanding accuracy in color reproduction even under harsh lighting conditions.

Camera Features:

- 20-bit processing technology
- CCD sensor with Wide Dynamic Range
- Dynamic engine with Smart BLC

- Detail enhancement
- True day/night performance with switchable filter

The EX65 holds all major international explosion-protected certifications for safe use in almost any region of the world. In addition, the EX65 meets NEMA 4X and IP67 ratings. The EX65 has undergone vibration and shock testing to IEC standards, as well as Highly Accelerated Life Testing (H.A.L.T.), which pushes the limits of products to ensure reliability throughout the product's lifetime.

For performance in complete darkness, there is an infrared illuminator available with 3D diffuser technology to guarantee a crisp, clear, evenly-illuminated image even in pitch black darkness. Infrared illumination also eliminates the need for any conventional high voltage lighting to be installed, which cuts costs significantly. For more information, please refer to the EX65 Explosion Protected Illuminator datasheet.

The EX65 gives you the confidence to ensure a safe workplace while getting the picture in the world's most volatile locations.

## System overview

### Extreme Environment Ready

The EX65 Explosion Protected Camera includes a camera and lens installed and pre-wired into an electropolished 316L stainless steel housing offering

excellent corrosion protection. For less corrosive environments, an anodized aluminum configuration is also available. The EX65 holds the most common explosion-protected certifications for guaranteed safe operation in explosive environments and also NEMA 4X and IP67 ratings for wet locations. For operation in areas prone to vibration, the EX65 has been tested to IEC standards for vibration and shock.

### **Integrated Junction Box**

The integrated junction box allows for easy connections to the terminal block for power and alarm outputs. Video is available via a BNC connector or ST fiber connector eliminating the need for a costly external junction box. The alarm-out can be used for switching on external illuminators and can trigger events if motion is detected. In addition, there is sufficient room for the UTP module or extra wiring if multiple cameras or illuminators are daisy chained together.

### **Ease of Installation**

The EX65 features one-piece installation and an integrated junction box for easy mounting and wiring. The EX65 is versatile enough to mount in multiple applications and features remote camera configuration via a standard video cable (Bilinx).

### **Detail in Extreme Lighting**

Cameras in industrial applications must overcome the challenge of providing a detailed image when lighting varies across the scene, such as the dark corners and the bright open areas on the deck of an offshore oil rig. To produce a clear picture in these conditions and to reveal details previously unseen, the EX65 combines 20-bit image processing with wide dynamic range. 20-bit image processing simultaneously captures the detail in both bright highlights and in deep shadows. The wide dynamic range, then, ensures that the camera delivers excellent contrast in the bright areas and details in the dark areas.

### **2X-Dynamic and SmartBLC**

Using 2X-Dynamic technology, pixel-by-pixel analysis provides the user with the most detailed information. Turn on SmartBLC to automatically compensate the image without the need for complicated set-up or without compromising dynamic range.

### **Detail Enhancement**

Features such as Autoblack and Sharpness further improve the details in a scene, pixel by pixel.

### **Day/Night Mode**

The day/night mode provides enhanced night viewing by increasing the IR sensitivity. The IR filter switches from color to monochrome automatically by sensing the illumination level. The filter can also be switched manually via the Bilinx coaxial control interface. An internal through-the-lens IR detector enhances the monochrome mode stability, as it prevents reverting to

the color mode when IR illumination is dominant. IR contrast is also measured and used to handle reflected IR light in outdoor scenes.

### **Bilinx Technology**

Bilinx is a bidirectional communication capability embedded in the video signal of the EX65. Technicians can check status, change camera settings, and update firmware from virtually anywhere along the video cable. Bilinx reduces service and installation time, provides for more accurate set-up and adjustment, and improves overall performance. In addition, Bilinx uses the standard video cable to transmit alarm and status messages, providing superior performance without additional installation steps.

### **Video Motion Detection**

The built-in video motion detector allows you to select a programmable area with individual thresholds. The global scene change detector minimizes false alarms caused by sudden lighting condition changes, such as switching on or off the indoor or security lighting. When motion is detected, alarms can be displayed in the video signal, the output relay can be closed or an alarm message can be transmitted via Bilinx.

### **SensUp Dynamic**

By increasing the integration time up to 10 times on the CCD, the effective sensitivity in low light is dramatically enhanced. This is especially useful when relying only on moonlight for illumination.

### **Transmission Versatility**

Enjoy the convenience of having video transmission options. A standard video-out via a BNC connector is accessible in the junction box with enough room for the optional UTP module. A multimode fiber optic video out configuration is also available via the integrated module; conveniently located in the junction box for quick connection to a fiber network via an ST connector.

### **Wide Temperature Range**

Designed with the harshest conditions in mind, the EX65 welcomes deployment in the toughest areas on the planet including the subzero conditions found in the far north or the scorching heat found in hostile deserts. The impressive  $-50^{\circ}\text{C}$  to  $+60^{\circ}\text{C}$  ( $-58^{\circ}\text{F}$  to  $+140^{\circ}\text{F}$ ) temperature range is standard on all aluminum models.

### **Global Explosion Protection Certification**

The EX65 holds all major international explosion protected certifications for global installation. As a UL listed product the EX65 is certified for the division and zone system per the NEC standards. For Europe it holds the ATEX certification. The EX65 has been tested against and conforms to the international IECEx scheme. For Brazil the EX65 holds the INMETRO certification.

**Infrared Illumination**

For a complete 24-hour imaging solution, the EX65 Camera can be paired with an EX65 Illuminator to provide a crisp clear picture in complete darkness. The Illuminator turns on when the camera switches to night mode through a telemetry connection which is easily accessible in the junction box. For more information please refer to the EX65 Explosion Protected Illuminator datasheet.

**Certifications and approvals**

Region	Certification
Europe	CE Declaration of Conformity
USA	UL, FCC
Canada	cUL
Brazil	INMETRO
International	ATEX, IECEx

**Electromagnetic Compatibility (EMC)**

Emission	EN55022 class B, FCC part 15 class B
Immunity	EN 61000-4, EN 50130-4:1996

**Safety**

UL 508, CAN/CSA C22.2 No. 60065-03

**Explosion Protection**

UL/cUL Listed 3RR9

UL/cUL Hazardous Locations Listed as per NEC Division and Zone requirements

- Class I, Div 1, Groups C, and D; Class II, Groups E, F, and G; Class III
- Class I, Zone 1, AEx d IIB T6; Ex d IIB T6 X
- AEx tD 21 T85°C
- DIP DIP A21 Ta85°C X

ATEX / IECEx

- DEMKO 10 ATEX 0948139X
- CE 0344 II 2 GD
- Ex d IIB T6 Gb
- Ex tb IIIC T85°C Db IP67

11/UL-BRHZ-0037

UL 1203, UL 60079-0, UL 60079-1, ANSI/ISA-61241-0, ANSI/ISA-61241-1, CAN/CSA C22.2 No. 30-M1986, CAN/CSA C22.2 No. 25-1966, CAN/CSA C22.2 No. 60079-0-07, CAN/CSA C22.2 No. 60079-1-07, CAN/CSA E61241-1-1-02, EN 60079-0:2006, EN 60079-1:2007, EN 60079-31:2009, IEC 60079-0:2009, IEC 60079-1:2007, IEC 60079-31:2008, INMETRO Portaria 179:2010, ABNT NBR IEC 60079-0:2008, ABNT NBR IEC 60079-1:2009

**Environmental**

UL Type 4X; IP67; Sinusoidal Vibration tested; Random Vibration tested; Shock tested; UL50, UL50E, IEC 60529, EN60068-2-6, EN60068-2-64, EN60068-2-27, CAN/CSA C22.2 No. 94.1-07, CAN/CSA C22.2 No. 94.2-07, CAN/CSA C22.2 No. 60529-05

Region	Certification
	Certificate of Conformity 11/UL-BRHZ-0037X
Europe	CE Declaration of Conformity
USA	UL E333679 Certificate of Compliance
	UL DEMKO 10 ATEX 0948139X
	UL Certificate of Conformity IECEx UL 10.0010X

**Installation/configuration notes**

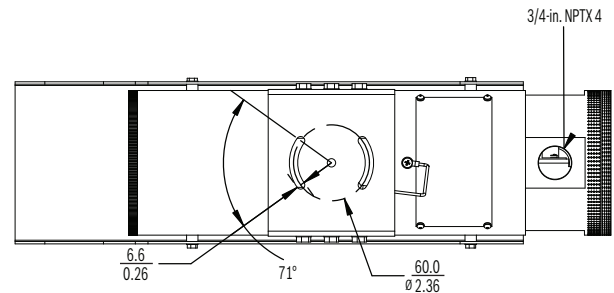

mm  
in.

**Bottom View**

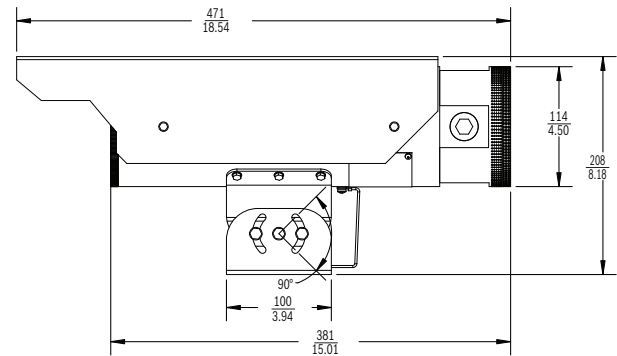

mm  
in.

**Side View**

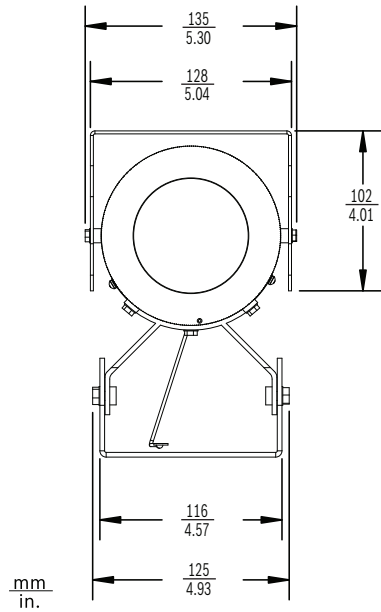

Front View

**Technical specifications**

**Electrical**

Rated Voltage	12–24 VAC, 50/60 Hz 12–24 VDC
CCD Type	1/3-in. Interline, WDR dual shutter

**Power Consumption**

Typical	Standard Models (BNC connector)	Fiber Optic Models (ST connector)
12 VDC (Tamb @ 20 °C) (68 °F)	6 W	7.7 W
24 VAC (Tamb @ 20 °C) (68 °F)	9.4 W	11.3 W
12 VDC (Tamb @ -50 °C) (-58 °F)	10.2 W	11.3 W
24 VAC (Tamb @ -50 °C) (-58 °F)	15.7 W	17.6 W
<b>Maximum</b>		
12 VDC (Tamb @ 20 °C) (68 °F)	8.0 W	9.5 W
24 VAC (Tamb @ 20 °C) (68 °F)	11.2 W	13.4 W
12 VDC (Tamb @ -50 °C) (-58 °F)	16.0 W	14.7 W
24 VAC (Tamb @ -50 °C) (-58 °F)	19.3 W	22.4 W

<b>Active Pixels</b>	
PAL Model:	752 x 582
NTSC Model	768 x 494

**Sensitivity** (3200 K, scene reflectivity 89%, F1.2)

	Full video (100 IRE)	Usable picture (50 IRE)	Usable picture (30 IRE)
Color	2.4 lx (0.223 fc)	0.47 lx (0.044 fc)	0.15 lx (0.0139 fc)
Color + SensUp 10x	0.24 lx (0.0223 fc)	0.047 lx (0.00437 fc)	0.015 lx (0.00139 fc)
Monochrome	0.98 lx (0.091 fc)	0.188 lx (0.0174 fc)	0.060 lx (0.0056 fc)
Monochrome + SensUp 10x	0.098 lx (0.0091 fc)	0.019 lx (0.00176 fc)	0.0060 lx (0.000557 fc)

Horizontal Resolution	540 TVL
Signal-to-Noise Ratio	>50 dB
Video Output	Composite video 1 Vpp, 75 ohm
Synchronization	Internal, Line Lock, HV-lock and Genlock (Burst lock) selectable
Shutter	Auto (1/50 [1/60] to 1/10000) selectable Auto (1/50 [1/60] to 1/50000) automatic flickerless, fixed selectable
Sensitivity Up	Adjustable from Off up to 10x
Day/Night	Color, Mono, Auto
Auto Black	Automatic continuous, Off
Dynamic engine	XF-Dynamic, 2X-Dynamic, SmartBLC
Dynamic range	120 dB (20-bit image processing)
Dynamic Noise Reduction	Auto, On/off selectable
Sharpness	Sharpness enhancement level selectable
SmartBLC	On (includes 2X-Dynamic) / Off
AGC	AGC On or Off (0–30 dB) selectable
Peak White Invert	On/Off
White Balance	ATW, ATWhold and manual (2500 to 10000K)
Alarm Output	VMD or day/night switch
Alarm Output Relay	30 VAC or +40 VDC, Max 0.5 A continuous, 10 VA

Cable Compensation (coax version only)	Up to 1000 m (3000 ft) coax without external amplifiers (automatic set-up in combination with Bilinx coaxial communication)
Camera ID	17-character editable string, position selectable
Test Pattern Generator	Color bars 100%, Grayscale 11-step, Sawtooth 2H, Checker board, Cross hatch, UV plane
Modes	Six (6) preset programmable modes
Remote Control (coax version only)	Bilinx coaxial bi-directional communication
Video Motion Detection	One area, fully programmable
Privacy Masking	Four (4) independent areas, fully programmable
Controls	OSD with soft-key operation (multi-lingual)
Lens	5–50 mm IR corrected
Heater	Included

### Fiber Optic Specifications

Optical Connector Type	ST
Optical Fiber Compatibility	50/125 $\mu\text{m}$ or 62.5/125 $\mu\text{m}$ , graded index multimode glass fiber rated for a minimum bandwidth of 600 MHz-Km. For 50/125 fiber, subtract 4 dB from the specified optical budget value.
Optical Distance Specifications	Specified transmission distances are limited to the optical loss of the fiber and any additional loss introduced by connectors, splices, and patch panels. The modules are designed to operate over the entire optical loss budget range, so they do not require a minimum loss in order to operate.
Number of Fibers	One (1)
Optical Budget	14 dB
Maximum Distance	4.0 km (2.5 miles)
Technology Type	AM Video modulation
Wavelength	850 nm
Optical Emitter	LED
Transmitter Output Power	25 $\mu\text{W}$ (–16 dBm)
Video Bandwidth	5 Hz to 10 MHz
Differential Gain	< 5%
Differential Phase	< 5°
Tilt	< 1%
Signal-to-Noise Ratio (SNR)	> 55 dB @ 10 dB attenuation > 60 dB @ 7 dB attenuation

### Mechanical

Dimensions (L x W x H)	381 x 114 x 114 mm (11.01 x 4.5 x 4.5 in.) without sunhood or mounting cradle
Weight	Stainless Steel: 12.9 kg (28.5 lb) Aluminum: 6.4 kg (14 lb)
Construction	Electropolished 316L Stainless Steel or Anodized Aluminum
Bracket	Pan( $\pm 36^\circ$ )/Tilt( $\pm 45^\circ$ ), mounting cradle included
Cable Entry	Four (4) 3/4-in. NPT entries; conduit seal included with NTSC models; M20 adapter included with PAL models
View Window	9-mm thick borosilicate float glass

### Environmental

Operating Temperature	
- Aluminum models	-50 °C to 60 °C (-58 °F to 140 °F)
- Stainless steel models	-50 °C to 55 °C (-58 °F to 131 °F)
Storage Temperature	
	-55 °C to 70 °C (-67 °F to 158 °F)
Operating Humidity	
	0 to 100% relative (condensing, after installed and sealed)
Storage Humidity	
	20 to 98% relative (non-condensing)

### Ordering information

#### VEN-650V05-1A3 Aluminum EX65 Explosion Protected Camera

Day/Night, 1/3-in. CCD, 2X DSP, 5-50 mm, PAL, 12-24 VDC/VAC  
Order number **VEN-650V05-1A3**

#### VEN-650V05-2A3 Aluminum EX65 Explosion Protected Camera

Day/Night, 1/3-in. CCD, 2X DSP, 5-50 mm, NTSC, 12-24 VDC/VAC  
Order number **VEN-650V05-2A3**

#### VEN-650V05-1A3F Aluminum EX65 Explosion Protected Camera

Day/Night, 1/3-in. CCD, 2X DSP, 5-50 mm, PAL, Fiber, 12-24 VDC/VAC  
Order number **VEN-650V05-1A3F**

#### VEN-650V05-2A3F Aluminum EX65 Explosion Protected Camera

Day/Night, 1/3-in. CCD, 2X DSP, 5-50 mm, NTSC, Fiber, 12-24 VDC/VAC  
Order number **VEN-650V05-2A3F**

#### VEN-650V05-1S3 Stainless Steel EX65 Explosion Protected Camera

Day/Night, 1/3-in. CCD, 2X DSP, 5-50 mm, PAL, 12-24 VDC/VAC  
Order number **VEN-650V05-1S3**

**VEN-650V05-2S3 Stainless Steel EX65 Explosion Protected Camera**

Day/Night, 1/3-in. CCD, 2X DSP, 5-50 mm, NTSC, 12-24 VDC/VAC

Order number **VEN-650V05-2S3**

**VEN-650V05-1S3F Stainless Steel EX65 Explosion Protected Camera**

Day/Night, 1/3-in. CCD, 2X DSP, 5-50 mm, PAL, Fiber, 12-24 VDC/VAC

Order number **VEN-650V05-1S3F**

**VEN-650V05-2S3F Stainless Steel EX65 Explosion Protected Camera**

Day/Night, 1/3-in. CCD, 2X DSP, 5-50 mm, NTSC, Fiber, 12-24 VDC/VAC

Order number **VEN-650V05-2S3F**

**Accessories**

**UPA-2430-60 Power Supply**

120 VAC, 60 Hz, 24 VAC, 30 VA Out

Order number **UPA-2430-60**

**UPA-2450-60 Power Supply, 120 V, 60 Hz**

120 VAC, 60 Hz, 24 VAC, 50 VA Out

Order number **UPA-2450-60**

**UPA-2420-50 Power Supply**

220 VAC, 50 Hz, 24 VAC, 20 VA Out

Order number **UPA-2420-50**

**UPA-2450-50 Power Supply, 220 V, 50 Hz**

220 VAC, 50 Hz, 24 VAC, 50 VA Out

For use with certain 24 VAC camera models.

Order number **UPA-2450-50**

**VDA-455UTP**

Adaptor for UTP twisted pair output

Order number **VDA-455UTP**

**Software Options**

**VP-CFGSFT Configuration Tool for Imaging Devices**

Camera configuration software for use with Bilinx cameras

Order number **VP-CFGSFT**

**Represented by:**

**Americas:**

Bosch Security Systems, Inc.  
130 Perinton Parkway  
Fairport, New York, 14450, USA  
Phone: +1 800 289 0096  
Fax: +1 585 223 9180  
security.sales@us.bosch.com  
www.boschsecurity.us

**Europe, Middle East, Africa:**

Bosch Security Systems B.V.  
P.O. Box 80002  
5617 BA Eindhoven, The Netherlands  
Phone: + 31 40 2577 284  
Fax: +31 40 2577 330  
emea.securitysystems@bosch.com  
www.boschsecurity.com

**Asia-Pacific:**

Robert Bosch (SEA) Pte Ltd, Security Systems  
11 Bishan Street 21  
Singapore 573943  
Phone: +65 6571 2808  
Fax: +65 6571 2699  
apr.securitysystems@bosch.com  
www.boschsecurity.asia

**China:**

Bosch (Shanghai) Security Systems Ltd.  
201 Building, No. 333 Fuquan Road  
North IBP  
Changning District, Shanghai  
200335 China  
Phone +86 21 22181111  
Fax: +86 21 22182398  
www.boschsecurity.com.cn

**America Latina:**

Robert Bosch Ltda Security Systems Division  
Via Anhanguera, Km 98  
CEP 13065-900  
Campinas, Sao Paulo, Brazil  
Phone: +55 19 2103 2860  
Fax: +55 19 2103 2862  
latam.boschsecurity@bosch.com  
www.boschsecurity.com