



Installation & Operation Manual

For

Emergency/Information Phones

Section	Page
Getting Started	2
Hardware Installation	3
Software Programming	6
Operation	14
10-Number Autodialing Keypads	18
Frequently Asked Questions	19
Basic Trouble-Shooting	21
Talk-A-Phone Co. Limited Warranty	23
FCC Information	24
Phone Line Specifications	25
Information to the User	26
Maintenance	26

Quick Programming Guide on Page 6

Getting Started

I. Getting Started

A. Introduction

Thank you for your purchase of this Emergency/Information Phone. All Talk-A-Phone equipment is built with an exceptional standard of quality and should provide years of reliable service.

This manual will guide you through the installation of this unit and provide comprehensive operating instructions. Please read this instruction manual COMPLETELY before you install this unit.

Once you have installed the unit and are familiar with its operation, store this manual in an accessible location for future reference.

B. What Is In The Box

- Emergency/Information Phone
- Owner Information Card
- Instruction Manual
- Six 10-24 ovalhead tamper-proof screws (part 42867, flush mount phones only)
- Four #6 screws (part 42705, surface mount indoor phones only)



You should inspect your emergency/information phone when you open the box for possible damage in shipment. If it is damaged, or any of the components are missing, contact your Talk-A-Phone Co. distributor immediately. Do not discard any hardware or packing material before you are certain you have all the items listed above, and the unit is installed and functioning correctly.

C. Technical Requirements

- Dedicated* P.O.T.S. type phone company line or Analog PBX line—you must know if your phone is on a PBX before you begin programming.

If connected to a PBX, your extension must provide:

- at least 24 Volts at 20 mA off-hook (no current is drawn on-hook)
- either a disconnect pulse (voltage drop at end of call) or 30-seconds of silence after hang-up (no re-order or howler feature)
- If connected to a P.O.T.S. line, there must be no special features, such as hook-flash, call-waiting, auto-redial when busy or voice-mail. If the telephone company has activated any such features or your phone line is "feature ready", contact them to have these features turned off.

* If you are installing multiple units with a limited number of lines, you should consider using either the Talk-A-Phone EC-2 or EC-8 Consolidator. The EC-2 allows you to connect two Talk-A-Phone phones to a single communication line, while the EC-8 allows you to connect up to eight Talk-A-Phone phones to a single communication line. Contact your distributor or call Talk-A-Phone Customer Support for additional information regarding these units.

II. Hardware Installation

Talk-A-Phone phones are divided into two categories: 100-series indoor phones and 400-series outdoor phones. Outdoor phones are subdivided into surface mount and flush mount. The ETP-103 Series is listed separately. Follow the installation procedure listed below for your phone type.



Installation should be performed by qualified personnel only in accordance with the National Electrical Code and other federal, state and local statutes and building codes. Using shielded cable is recommended to avoid noise, hum, and other operational anomalies.

You will need a #10 spanner screwdriver or bit to complete this installation (except for ETP-103 or ETP-100M series phones). If you do not own one, you may purchase one from your local industrial supply store or from Talk-A-Phone. Contact your Talk-A-Phone distributor for purchasing information.

A. 100 Series Indoor Phones

1. Plug the RJ11 connector on the cable extending from the unit into an RJ11 receptacle connected to the phone line (red is ring, green is tip).
2. If your phone has the AUX option, you have one auxiliary input and two auxiliary outputs. The Black wire is the common wire. The auxiliary outputs are rated at a maximum of 50 mA at 30V DC or AC.
 - a. The Brown and Black wires are the auxiliary input.
 - b. The Red and Black wires are auxiliary output #1.
 - c. The Orange and Black wires are auxiliary output #2.

If your phone has the AUX option and you choose not to use it, tape off the leads to prevent shorting.

3. Place the phone in the desired location on the mounting surface and secure it with included screws.



Talk-A-Phone model MS-400 Mounting Sleeve is designed to accommodate both indoor and outdoor flush mounted phones. Contact your distributor or Talk-A-Phone Co. for more information.

B. 400 Series Outdoor Surface Mount Phones (ETP-401, ETP-402, etc.)

Wiring extends from the rear of this unit (not bottom) for mounting to a pole or other hollow surface. You cannot attach conduit directly to this phone. If you want to run conduit directly to the phone, from either the back or the bottom, you should consider purchasing the Talk-A-Phone ETP-SME Surface Mount Extension. Contact your Talk-A-Phone distributor for purchasing information.

1. Remove the attached saddle bracket from the phone by unscrewing the four #10 spanner screws. **DO NOT DISCARD THESE SCREWS.**
2. Place the saddle bracket or ETP-SME in the desired location on the mounting surface and secure with four screws.
3. Plug the RJ11 connector on the cable extending from the unit into an RJ11 receptacle connected to the phone line (red is ring, green is tip).

Hardware Installation

4. Connect the Green wire to Earth Ground.
5. Your phone has one auxiliary input and two auxiliary outputs. The auxiliary outputs are rated at a maximum of 50 mA at 30V DC or AC.
 - a. The Brown and Blue wires are the auxiliary input.
 - b. The Red and White wires are auxiliary output #1.
 - c. The Orange and Black wires are auxiliary output #2.



If your wires do not match these color combinations, you may have a different generation of phone. See section A. Indoor Emergency Phones above for the correct combination of AUX wires.

To use the auxiliary input feature, contact Talk-A-Phone to request an ETP-AUXIN-KIT at no charge. This is not required for models ETP-400-MOD2 or ETP-400V-MOD2.

If the AUX ports are not used, tape off the AUX leads to prevent shorting.

6. Place the phone into the saddle bracket or ETP-SME and secure it with the four #10 spanner screws. The saddle bracket is not used if installing ETP-SME Surface Mount Extension.

C. 400 Series Outdoor Flush Mount Phones

Talk-A-Phone offers several mounting accessories for our outdoor flush mounting phones, ranging from simple back boxes to towers with pan-and-tilt camera domes. For detailed mounting accessory installation instructions, consult the literature that accompanies the relevant mounting accessory. Each phone comes with six #10 spanner screws. If you do not own this type of screwdriver or bit, you may purchase one at your local industrial supply store or from Talk-A-Phone. Contact your Talk-A-Phone distributor for purchasing information.

1. Plug the RJ11 connector on the cable extending from the unit into an RJ11 receptacle connected to the phone line (red is ring, green is tip).
2. Connect the Green wire to Earth Ground.
3. Your phone has one auxiliary input and two auxiliary outputs. The auxiliary outputs are rated at a maximum of 50 mA at 30V DC or AC.
 - a. The Brown and Blue wires are the auxiliary input.
 - b. The Red and White wires are auxiliary output #1.
 - c. The Orange and Black wires are auxiliary output #2.



If your wires do not match these color combinations, you may have a different generation of phone. See section A. Indoor Emergency Phones above for the correct combination of AUX wires.

To use the auxiliary input feature, contact Talk-A-Phone to request an ETP-AUXIN-KIT at no charge. This is not required for models ETP-400-MOD2 or ETP-400V-MOD2.

If the AUX ports are not used, tape off the AUX leads to prevent shorting.

4. Place the phone into its mounting accessory and secure with six #10 spanner screws (included).

D. Installing ETP-103 Series Phones

Models ETP-103 and ETP-103V are designed to mount behind an elevator car operating panel and require connection to a push button with LED capability on the car operating panel.

1. Determine the position where you will mount the phone. Be sure the phone speaker and microphone are placed directly behind the speaker grille in the car operating panel or mounting surface.
2. Mark the four mounting holes. Weld four 0.16" diameter threaded studs to these spots. These studs should form a rectangle that is 7.2"h x 3.0"w. (Note: These studs are usually pre-welded in place by the car operating panel manufacturer.)
3. Place the phone onto the studs and secure with nuts.
4. Plug the RJ11 connector on the cable extending from the unit into an RJ11 receptacle connected to the phone line (red is ring, green is tip).
5. Connect the Brown and Black wires to the phone activation switch. The Black wire is the common wire.
6. Connect a Red wire and the Black wire to the LED. The phone comes with two red wires, to operate two LED's simultaneously if necessary. (Note: If LED does not work, reverse polarity.)

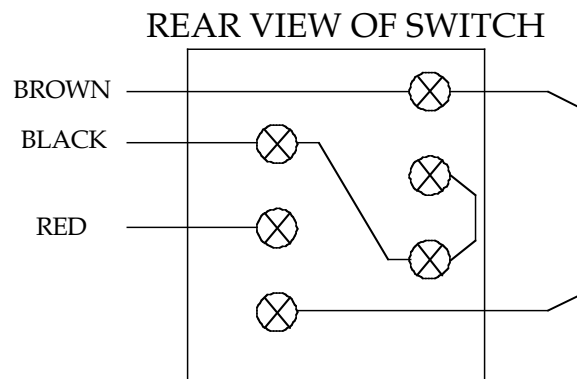

NOTES:

- 1) Many elevator car operating panel manufacturers "push to talk" buttons use an LED manufactured by Data Display Products (part number 5SB-RLP2). One is packed with the unit.
- 2) When inserting the LED into the button, be sure that the plus side of the LED is connected to the red wire of the phone.
- 3) Models ETP-103 and ETP-103V are designed to connect to either one or two Car Stations (i.e., one on each side of door). If you are only connecting to one button, tape up the second set of wires to prevent shorting.
- 4) At the Branch's discretion the "alarm" push button can be used in lieu of the "push to talk" pushbutton.
- 5) The above applications MUST be approved by the local code authority inspector.

Figure 1. Wiring an ETP-103 or ETP-103V to Elevator "Push to Talk" Pushbuttons

III. Software Programming

A. Quick Programming Guide

Programming your Talk-A-Phone unit is, in most cases, quite simple. While it is recommended that you read the complete instructions below before you begin, the following quick guide will serve many applications. After entering each code you should hear one beep, confirming the acknowledgement of the command:

1. Call your emergency/information phone. It answers with a series of tones.
2. Enter the default Guard Access Code: *4**.
3. Enter the primary phone number your Talk-A-Phone unit should dial upon activation: *13*[Phone Number]*.
4. Enter the secondary phone number your Talk-A-Phone unit should dial if the primary number is busy or does not answer (optional): *23*[Phone Number]*.
5. If the Talk-A-Phone unit will be an extension of a phone system (i.e. on a PBX), enter these three codes into the Emergency/Information phone, each followed by the acknowledgement beep: *55*, *18*5*, *14*3*.
6. If your phone has the Intelli-Voice Option (the model number ends in "V"), enter *58* to record a 10 second message. The Talk-A-Phone unit will beep once before the recording starts and beep the second time at the end of the message recording. Enter *59* to play back the recorded message.
7. Enter # to hang up the Talk-A-Phone unit.

B. Detailed Programming Information: Before Programming

There are several questions you must answer in order to program your phone. You may have to contact the communication manager of the facility to get the answers to some of these questions. You should write down your answers on the back of this manual for future reference. Before you proceed, make sure that the phone is on a dedicated line. (If it shares a line with other emergency phones, make sure you are using an EC-2 or EC-8 Consolidator.) In other words, there must not be *any* other devices using this communication line.

1. What is the phone number of the line this phone is connected to? You need to know this, as you have to call the phone in order to program it.
2. What is the location of the phone? List all pertinent information, such as address, elevator car number, hallway, etc.
3. Is the phone line a phone company line, or is it an analog PBX extension?
4. What is the primary number the phone should dial upon activation?
5. Is there a secondary number the phone should call in the event that the first number does not answer or is busy? A secondary number is not required for the phone to function, but is recommended.
6. Does the phone have the Intelli-Voice option? That is, does the phone model number end with a "V"?
7. If the phone is on a PBX line, is the extension set for "Ring Down?"

8. If the phone is on a PBX line do you have to dial a prefix, such as 9, first?
9. If the phone has auxiliary leads, are there any devices connected to the auxiliary input or outputs? 100 series phones with the letters "AUX" in the model number and all 400 series phones have auxiliary leads.
10. If you are using either an EC-2 or an EC-8 Consolidator, which port is this phone connected to?

C. General Programming Instructions

Programming can be done from any standard touch-tone telephone. It is essential to program at least one telephone number for the Talk-A-Phone unit to operate. After entering any code into the Talk-A-Phone unit, you should hear a single beep. This indicates that the phone has understood and accepted your command. Two beeps indicate that the phone did not properly receive a command. After entering the access code, the order in which codes are entered is irrelevant.

To begin programming, call the Talk-A-Phone unit. Enter the factory set Guard Access Code, *4**. You are now able to program the features described below.

D. Access Codes

This unit offers two levels of software security, each with its own password. The Guard Access security level allows authorized personnel to program the phone and use operational codes. The Master Access security level allows the system administrator to change the Guard Access and Master Access Codes, thereby prohibiting unauthorized system access.

If you lose the Master Access Code, you will have no way of changing the Guard Access Code other than a hardware reset of the unit, which reverts ALL programming to original factory settings (For instructions see FAQ, page 19).

Command	Function
3 ...[up to 8 digits]*	Master Access Code entry to change Guard Access Code or Master Access Code (Default Code is *3*12345678*)
4 ...[up to 8 digits]*	Guard Access Code entry for phone programming (Default Code is *4**)
10 ...[up to 8 digits]*	Programs and stores a new Master Access Code
11 ...[up to 8 digits]*	Programs and stores a new Guard Access Code
75	Allow the performance of Operation Codes *25*, *26*, *28*, and *29* WITHOUT the Guard Access Code—See Operation Codes, page 11.
76	REQUIRES the Guard Access Code to perform Operation Codes *25*, *26*, *28*, and *29*—See Operation Codes, page 10. (default)

E. Primary & Secondary Phone Number Codes

You must program a primary phone number for the unit to function correctly. You may also program a secondary phone number. If the first number is busy or does not answer after a specified number of rings (see PBX/Configuration Codes, page 11), the phone will hang up and try again, this time using the second phone number

Software Programming

if one is programmed, or the first number if no second phone number exists. It will retry these numbers until the call is answered or the conversation time elapses (see PBX/Configuration Codes, page 10).

If your phone has two buttons, the top button is Button #1 and the bottom button is Button #2. If you have a Keypad phone, Button #2 **cannot** be programmed to dial an outside number. This button is used to get a dial tone before using the keypad to dial.

Command	Function
13 ...[up to 18 digits]*	Programs the primary number called by Button #1
23 ...[up to 18 digits]*	Programs the secondary number called by Button #1
80 ...[up to 18 digits]*	Programs the primary number called by Button #2
81 ...[up to 18 digits]*	Programs the secondary number called by Button #2

Entering "#" inserts a four second pause when placed in a dial string.

For example:

- When using 9 to obtain an outside line, enter "9#" and then the number desired. This allows the phone system to switch to an outside line without missing dialed digits.
- When dialing pagers or voice mail systems, use "#" in the number string where a pause is required.

F. Speaker & Microphone Codes

The speaker and microphone turn on automatically when the unit is activated. The caller will hear dial tone, dialing, and busy signals. You may wish to silence these call progress tones. You may also wish to activate the silent call in feature by activating the speaker and microphone when *you* call the *unit*.

Command	Function
5	Turns on unit speaker & microphone when you call in to the unit. Effective for that call only.
78	Automatically turns on unit speaker & microphone every time you call in to the unit.
79	Cancels the *78* command (default)
19	Makes call progress tones audible (default)
20	Makes call progress tones silent (Mode I only)



If *78* has been programmed, future calls to the unit will begin in communication mode. To perform any programming, hold the * button down for a full second prior to entering the guard code. If the phone you are calling from cannot play a tone for 1 second (e.g. a cell phone), you may need to call from a different phone.

G. Intelli-Voice Option Codes

The "V" option allows you to program a voice message that will play automatically *when the guard answers the call*. This message serves to identify the unit to the guard station.

Command	Function
72	Set the message length to 5 seconds
73	Set the message length to 10 seconds (default)
74	Set the message length to 16 seconds
58	Record the identification message after the beep and until the next beep
59	Playback the recorded message
77	Disable the automatic playback of the recorded message when a call is answered and <i>delete the message</i>
70	Disable automatic playback of the recorded message when a call is answered, but <i>do not delete the message</i>
71	Enable the automatic playback of the recorded message when a call is answered (default)
84	Activate the message when pressing Button #1 only (default)
85	Activate the message when pressing Button #2 only
86	Activate the message when pressing either Button #1 or Button #2

H. Phone ID Codes

An important function of the phone is the ability to identify itself and its location to the guard station, because the caller may be unable to do so. There are several methods of accomplishing this task. One method is to have the phone transmit a DTMF identification number when the call is answered.

- This DTMF transmission can be received by the Talk-A-Phone EB-200 Base Station or by the Talk-A-Lert™ software (model ETP-TAL).
- The code is 6 digits long and any leading digits you do not enter will automatically be 0. For example, if you enter a code of 23, it will be transmitted as 000023.
- You should use codes that are logical for your environment. For example, if you want to identify the third elevator in the second elevator bank of the fifth building on campus, you might use the code 050203.

Command	Function
12 ...[six digits]*	Program the phone Identification number
49	Suppress automatic transmission of the phone ID (default)
50	Automatically transmit the phone ID when guard station answers a call ¹
104	Transmit the phone ID when the phone answers a call ² (default)
105	Suppress transmission of the phone ID when the phone answers a call ³

¹ Required for use with Talk-A-Lert base-station software or EB-200 base station

² Required for use with Talk-A-Lert polling software

³ Not available for ETP-100 Series phones

Software Programming

I. Auxiliary Device Automatic Activation Codes

100 series phones with the letters "AUX" in the model number and all 400 series phones have auxiliary leads¹. You can connect one auxiliary input device and two output devices to these leads. The following codes allow you to control the function of the auxiliary output leads (also see Operation Codes, page 10).

Command	Function																
24 ...[0 -	Sets "ON" time for Auxiliary Output #1 (incoming calls only)																
27 ...[0 -	Sets "ON" time for Auxiliary Output #2 (incoming calls only)																
	<table border="1"> <thead> <tr> <th>Value</th> <th>"ON" Time</th> </tr> </thead> <tbody> <tr> <td>0</td> <td>Continuously ON for duration of call</td> </tr> <tr> <td>1</td> <td>1 Second (default)</td> </tr> <tr> <td>2</td> <td>3 Seconds</td> </tr> <tr> <td>3</td> <td>5 Seconds</td> </tr> <tr> <td>4</td> <td>10 Seconds</td> </tr> <tr> <td>5</td> <td>30 Seconds</td> </tr> <tr> <td>6</td> <td>60 Seconds</td> </tr> </tbody> </table>	Value	"ON" Time	0	Continuously ON for duration of call	1	1 Second (default)	2	3 Seconds	3	5 Seconds	4	10 Seconds	5	30 Seconds	6	60 Seconds
Value	"ON" Time																
0	Continuously ON for duration of call																
1	1 Second (default)																
2	3 Seconds																
3	5 Seconds																
4	10 Seconds																
5	30 Seconds																
6	60 Seconds																
	Note: Timer is only for calls made TO the emergency phone. If an AUX is activated by a call FROM an emergency phone, the AUX contacts will remain closed for the duration of the call.																
87	Sets Button #1 to activate Output #1																
88	Cancels *87* command (default)																
56	Sets Button #1 to activate Output #2																
57	Cancels *56* command (default)																
90	Sets Button #2 to activate Output #1																
91	Cancels *90* command (default)																
92	Sets Button #2 to activate Output #2																
93	Cancels *92* command (default)																
64	Make Auxiliary Output #1 drive an additional LED																
65	Cancels *64* command (default)																

¹Except model ETP-401P Swimming Pool Emergency Phone.



On models with keypads, the button that activates the keypad cannot be programmed to automatically activate the auxiliary outputs.

J. Operation Codes

The following codes can be used to perform functions during a conversation:

Command	Function
*	Enter Programming Mode when in Communication Mode (See *78*, Page 9)
6	Provides a momentary closure to the Output #1
9	Elicit the phone ID number
25	Turn ON the Auxiliary Output #1
26	Turn OFF the Auxiliary Output #1
28	Turn ON the Auxiliary Output #2
29	Turn OFF the Auxiliary Output #2
#	Immediately disconnect a call

K. PBX/Timing Configuration Codes

Command	Function
*14*1*	MODE I: Sets Talk-A-Phone unit for Central Office Trunk Line (default)
*14*2*	MODE II: Sets Talk-A-Phone unit for PBX <i>when an EC-8 Consolidator is used</i>
*14*3*	MODE III: Sets Talk-A-Phone unit for PBX <i>when an EC-8 Consolidator is not used</i>
17 ...[minutes]*	Sets the conversation timer (1 – 4,320 minutes) (default is 12 minutes)
18...[ring cycles]*	Sets the number of ring cycles (1 – 9) before the Talk-A-Phone unit aborts a call and either redials the primary number or switches to the secondary number (default is 9 ring cycles)
100	0.5 second hang-up on busy or no answer (default on ETP-100 Series)
101	2.25 second hang-up on busy or no answer ¹ (default on ETP-400 Series)
102	51ms on/off dialing speed (default)
103	102ms on/off dialing speed ¹
40 ...[0 – 10]*	Sets delay before phone dials (0 – 10 seconds) May be used to wait to obtain PBX dial tone (default is 2 seconds)
53	Sets the Talk-A-Phone unit to disconnect if the Guard Station is silent for 60 seconds
54	Talk-A-Phone unit will not disconnect if Guard Station is silent (default)
55	Sets Talk-A-Phone unit to disconnect if the Guard Station is silent for 30 seconds
21	Configures Talk-A-Phone unit for use with a Rolm PBX or a Mitel PBX
22	Cancels *21* command (default)

¹Not available on ETP-100 Series phones.

You can configure your Talk-A-Phone unit for a variety of environments. For example, if your communication line is a PBX extension, you must configure the Talk-A-Phone unit to recognize the PBX system by programming the following functions:

- Telephone line type (Mode II or III): *14*[2 or 3]*
- Number of ring cycles before the Talk-A-Phone unit aborts a call and either redials the primary number or switches to the secondary number: *18*...[ring cycles]*
- Talk-A-Phone unit disconnects after 30 seconds of silence, *55*



When the Talk-A-Phone unit's extension is setup as a "ringdown" or "hot line", the Talk-A-Phone unit has to be programmed with a phone number: *13*...[5 digit number]* (Example: *13*12345*).

Software Programming

L. Code Summary (for models ETP-400KSE and ETP-402KSE see page 17)

Command	Function
6	Turn on Auxiliary Output 1 for 1 second
3 ...[up to 8 digits]*	Master Access Code entry to change Guard Access Code or Master Access Code (Default Code is *3*12345678*)
4 ...[up to 8 digits]*	Guard Access Code entry for phone programming (Default Code is *4**)
5	Turns on unit speaker & microphone when you call in to the unit Effective for that call only
9	Elicit phone ID number
10 ...[up to 8 digits]*	Programs and stores a new Master Access Code
11 ...[up to 8 digits]*	Programs and stores a new Guard Access Code
12 ...[six digits]*	Program phone Identification number
13 ...[up to 18 digits]*	Programs the primary number called by Button #1
14[1, 2, or 3]*	Configures phone MODE (1 is default)
17 ...[minutes]*	Sets conversation timer (1 – 4,320 minutes) (default is 12 minutes)
18 ...[ring cycles]*	Sets number of ring cycles (1 – 9) before phone aborts call and either redials the primary phone number or switches to the secondary phone number (default is 9 ring cycles)
19	Makes call progress tones audible (default) [Mode 1]
20	Makes call progress tones silent [Mode 1]
21	Configures phone for use with a Rolm PBX or a Mitel PBX
22	Cancels *21* command (default)
23 ...[up to 18 digits]*	Programs the secondary number called by Button #1
24 ...[0 – 6]*	Sets "ON" time for Auxiliary Output #1 (incoming calls only)
25	Turn ON Auxiliary Output #1, effective for that call only
26	Turn OFF Auxiliary Output #1, effective for that call only
27 ...[0 – 6]*	Sets "ON" time for Auxiliary Output #2 (incoming calls only)
28	Turn ON Auxiliary Output #2, effective for that call only
29	Turn OFF Auxiliary Output #2, effective for that call only
40 ...[0 – 10]*	Sets delay before phone dials (0 – 10 seconds) May be used to wait to obtain PBX dial tone (default is 2 seconds)
49	Suppress automatic transmission of the phone ID number (default)
50	Automatically transmit phone ID <i>when guard station answers call</i>
53	Sets phone to disconnect if the Guard Station is silent 60 seconds
54	Phone will not disconnect if Guard Station is silent (default)
55	Sets phone to disconnect if the Guard Station is silent 30 seconds
56	Sets Button #1 to activate Output #2 when pushed
57	Cancels *56* command (default)
58	Record your identification message
59	Playback the recorded identification message
64	Make Auxiliary Output #1 drive an additional LED

65	Cancels *64* command (default)
70	Disable automatic playback of the recorded message when a call is answered, but <i>do not delete the message</i>
71	Enable automatic playback of the recorded message when a call is answered (default)
72	Set message length to 5 seconds
73	Set message length to 10 seconds (default)
74	Set message length to 16 seconds
75	Allow the performance of Operation Codes *25*, *26*, *28*, and *29* WITHOUT the Guard Access Code—See Auxiliary Device Codes, page 10
76	REQUIRES the Guard Access Code to perform of Operation Codes *25*, *26*, *28*, and *29*—See Auxiliary Device Codes, page 10 (default)
77	Disable automatic playback of the recorded message when a call is answered and <i>delete the message</i>
78	Automatically turns on unit speaker & microphone every time you call in to the unit
79	Cancels the *78* command (default)
80 ...[up to 18 digits]*	Programs the primary number called by Button #2
81 ...[up to 18 digits]*	Programs the secondary number called by Button #2
84	Activate recorded message when pressing Button #1 only (default)
85	Activate recorded message when pressing Button #2 only
86	Activate recorded message when pressing either Button #1 or #2
87	Sets Button #1 to activate Output #1 when pushed
88	Cancels *87* command (default)
90	Sets Button #2 to activate Output #1 when pushed
91	Cancels *90* command (default)
92	Sets Button #2 to activate Output #2 when pushed
93	Cancels *92* command (default)
100	0.5 second hang-up on busy or no answer (default for ETP-100 Series)
101 ¹	2.25 second hang-up on busy or no answer (default for ETP-400 Series)
102	51ms on/off dialing speed (default)
103 ¹	102ms on/off dialing speed
104	Transmit phone ID when phone answers call (default)
105 ¹	Suppress transmission of phone ID when phone answers call

#	<ul style="list-style-type: none"> • If used during a call, immediately disconnect call • If used in a dial string, pause for four (4) seconds
6 ¹	Activates Auxiliary output #1 for 1 second

¹Not available on ETP-100 Series phones.

Operation

IV. Operation

A. General Information

When a push button on the Emergency/Information Phone is pressed, the first phone number programmed for that button will automatically be dialed. If a second phone number is also programmed for that button, it will automatically be dialed if the first number is busy or does not answer after a specified number of rings. Should the second phone number also be busy or not answer after the specified number of rings, the Phone will continue trying the first number and then the second number until the call is completed, or until the time limit set in field *17* has expired.

When the telephone at the Guard Station is answered, depending on model and programming, the Emergency/Information Phone may transmit its location by playing a recorded message or by transmitting DTMF tones. Afterwards—or immediately if no such feature is enabled—the caller may talk and listen hands-free without operating any controls.

The Guard Station can call into the Talk-A-Phone unit and activate it, in order to silently monitor a location as situation requires. Please be certain to obey all federal, state and local laws when using this feature.

B. Calling the Phone from the Guard Station

1. On a regular touch-tone telephone, enter the telephone number of the Phone you wish to call. After a short pause the unit will send a short series of audible coded tones to indicate that the Phone has answered.
2. Enter the Guard Access Code: *4* ...[up to 8 digits]*. The default code as shipped is *4**.
3. If you wish to talk with someone at the unit enter *5*.



If you have entered *5*, you cannot program the phone at this point. To enter the programming mode, hold down the star button on your telephone for at least one second. You will hear a beep to indicate that you are able to enter the guard code and begin programming again.



If a program code *78* is entered during the programming, the Talk-A-Phone unit's speaker and microphone will automatically activate every time the unit is called. To enter programming mode, hold down the star button on your telephone for at least one second. You will hear a beep to indicate that you are able to program the Talk-A-Phone unit.

C. Answering the Emergency/Information Phone

The telephone at the guard station will ring. The guard answers and speaks into his telephone and will be able to both listen and speak to the unit.



If *50* has been activated (see Phone ID Codes, Page 9), the unit will send a short series of audible DTMF tones, after which the conversation can continue.

D. Using a Talk-A-Phone unit with a PBX System (Mode II & Mode III)

Many PBX Systems use non-standard, propriety tones and signals. Examples of such PBX systems are the Rolm Systems 9751, 9000, 8000; AT&T systems 75, 85; and Northern Telecom Meridian and SL1. Depending upon your configuration, you should activate either the MODE II or MODE III software options that are built into the Talk-A-Phone unit.

If you are using a Talk-A-Phone EC-8 Consolidator, set the Talk-A-Phone unit to MODE II by simply entering codes *14*2*, *18*5*, and *55*, each followed by an acknowledgement beep. You must also program the EC-8 Consolidator into MODE II. See Model EC-8 Consolidator Instructions.

If you are *not* using an EC-8 Consolidator, simply enter special codes *14*3*, *18*5*, and *55*, each followed by an acknowledgement beep, to activate the MODE III on the Talk-A-Phone unit.

If you are using an EC-2 Consolidator on a PBX, you should enter special codes *14*3*, *18*5*, and *55*, each followed by an acknowledgement beep, to activate the MODE III on a Talk-A-Phone unit. An EC-2 consolidator does not have to be programmed.

Remember, the Talk-A-Phone unit requires a primary phone number to operate correctly. If you are using it with a PBX in "hot line" or "ringdown" mode, enter the phone number as *13*1234567* if used with a consolidator, or *13*12345* if no consolidator is used. Also enter *40*0* in addition to MODE II or MODE III commands.

E. Auxiliary Circuits

The Auxiliary Input allows you to activate the unit via remote devices that use a dry contact closure, such as Model SA-1 Scream Alert, an elevator emergency stop button, a sensor for a stuck elevator or open elevator door, smoke detector, alarm switch, etc. When the device is activated, the Emergency/Information Phone will automatically call out and establish full communication.



To use the auxiliary input feature, contact Talk-A-Phone to request an ETP-AUXIN-KIT at no charge. This is not required for models ETP-400-MOD2 or ETP-400V-MOD2.

The Auxiliary Outputs allow you to remotely activate two different functions, such as turning on a siren, light, or CCTV camera, opening a door, etc. In addition, Auxiliary Outputs can be programmed to automatically activate a strobe, siren, or CCTV when the call button on the unit is pushed. This is particularly useful when the unit is being used with a strobe light in parking facilities, campuses, and access control applications. The auxiliary outputs are rated at a maximum of 50 mA at 30V DC or AC.

Operation

Each auxiliary output on the 400 series phones has a separate ground. If you have an older unit that does not have separate grounds (or a 100 series phone) and you need this function, contact your distributor or Talk-A-Phone Sales department at 773-539-1100 for upgrade options.

F. Intelli-Voice "V" Option

Unless your model phone ends with "V" you do not have voice option.

This recorded message will automatically be heard by the party receiving the call as soon as they answer. Immediately thereafter, two-way conversation will occur. If you wish the message only to be heard upon command by the receiving party, enter *70*. The message will then be heard only if the receiving party enters *59* after receiving a call. The message can be repeated as many times as desired by using this command.

The recording can be made at the same time that other programming is done and can be changed at any time by calling the unit, entering the Guard Code, and recording a new message. This feature operates independently of the DTMF transmission of the unique identifier, which can either be active or suppressed as desired.

G. Two Button Models (ETP-402, ETP-400D)

Each button on the two-button Phone works just as on a single-button Phone. However, the red Emergency button on a two-button Phone always takes priority over the lower black button. If the upper Emergency button is pressed while a conversation is taking place via the lower black information button, the first call will automatically be disconnected and the emergency call will immediately be placed.

H. Keypads (ETP-400K, ETP-402K, ETP-400KS, ETP-402KS)

Some Talk-A-Phone models have a keypad. These models are denoted with the letter "K" in the model number. When the black call button is pushed, the user will hear a dial tone and can then use the standard 12-key pad to dial any number that has been authorized for that telephone line. When the called party answers, simply speak hands-free. When the called party hangs-up the unit will automatically disconnect.

Anytime the red Emergency button is pushed, the phone will automatically place the emergency call. If a conversation is taking place it will automatically be disconnected and the emergency call placed. To hang up the phone when placing a non-emergency call, simply press the lower button a second time.

Operation

Note: The black call button is used to take the phone off hook before placing a call with the keypad. This button **cannot** be programmed with an autodial phone number and it **cannot** be used to automatically activate an auxiliary output.

I. Special Keypad Model (ETP-400DKV)

Model ETP-400DKV operates like a standard two-button Emergency Phone (model ETP-400DV), with a keypad that can be used after a call is placed using the lower button.

When someone calls into the Emergency Phone, they will be able to silently monitor the location (the microphone is active, while the speaker is not).

During silent monitoring press 7 to activate the LED and press 8 to activate the speaker.

10-Number Autodialing Keypads

V. 10-Number Autodialing Keypads (ETP-400KE, ETP-400KSE, ETP-402KE, ETP-402KSE)

A. Programming

To program the autodialing phone numbers for buttons 0-9, use the following codes:

13 ...[up to 11 digits]*	Programs the phone number called by the RED button (if available)
23 ...[up to 11 digits]*	Programs the phone number called by keypad button #0
80 ...[up to 11 digits]*	Programs the phone number called by keypad button #1
81 ...[up to 11 digits]*	Programs the phone number called by keypad button #2
89 ...[up to 11 digits]*	Programs the phone number called by keypad button #3
90 ...[up to 11 digits]*	Programs the phone number called by keypad button #4
91 ...[up to 11 digits]*	Programs the phone number called by keypad button #5
92 ...[up to 11 digits]*	Programs the phone number called by keypad button #6
93 ...[up to 11 digits]*	Programs the phone number called by keypad button #7
94 ...[up to 11 digits]*	Programs the phone number called by keypad button #8
95 ...[up to 11 digits]*	Programs the phone number called by keypad button #9

To set the dialing speed, use the following codes:

96	51ms on/off dialing speed (default)
97	102ms on/off dialing speed

For other programming information, such as how to program for operation on a PBX, timing codes, etc., see Section III (page 6).

B. Operation

If the phone has a red button, pressing it will automatically dial the pre-programmed number and operate the auxiliary outputs if it is programmed to do so. On these units, there is no backup number for the top button.

When the black call button is pushed, the user will hear a dial tone and can then use buttons 0-9 on the-keypad to dial one of ten pre-programmed numbers. When the called party answers, simply speak hands-free. When the called party hangs-up the unit will automatically disconnect. To hang up the phone while it is active, simply press the black button a second time. When the call is in progress, the keypad is active for use with message systems, to enter a mailbox number, etc.



The black call button is used to take the phone off hook before placing a call with the keypad. This button **cannot** be programmed with an autodial phone number and it **cannot** be used to automatically activate an auxiliary output.

VII. Frequently Asked Questions

1. **How can I have multiple phones on one line?** Each Emergency/Information Phone requires either a dedicated phone line or analog PBX extension. However, using the EC-2 Consolidator you can connect two Phones onto a single line, and using the EC-8 Consolidator you can connect up to eight Talk-A-Phone phones onto a single line.

2. **I am using an EC-8 Consolidator in “local” mode. What should I enter as the phone number?** You must enter a phone number (see Primary and Secondary Phone Number Codes, page 8) even though your Talk-A-Phone unit is not using this number to connect to the local phone. We recommend entering *13*1234567* so that the person originating the call will hear the familiar sound of a 7 digit phone number.

3. **If I forget my Master Access Code, can Talk-A-Phone get into my unit through a software “back door?”** We have no way of programming an alternate Guard Access Code if you have lost your Master Access Code. For this reason, you may not wish to change the default Master Access Code unless you absolutely must. All codes should be written down and stored in a secure location. If you do forget your Master Access Code, you can perform a hardware reset, which is described in #4 below.

4. **I have made several mistakes in programming my phone and/or I don't know what has been programmed into my phone. Can I start over from the factory settings?** There is no programming code that resets you phone to factory settings. You *can* perform a HARDWARE RESET.
 - a) Disconnect the phone from the phone line. This ensures no power is connected to the phone.
 - b) For indoor phones, remove the front panel by unscrewing the security screws using a #6 spanner or a #6 spanner key, or by simply removing the bolts depending on model. Outdoor phones either don't require a spanner to disassemble or use a #10 spanner, depending on model.
 - c) Remove the back box by using a nut driver or socket.
 - d) Place the unit face down.
 - e) On the circuit board are four pins, their location varies with model. Three of the pins are covered, only one pin is visible. If you locate the mounting screw at the top left of the circuit board and move to the right about one inch you will see these pins on most models.
 - f) There are two jumpers in place on the pins. The pins are labeled “A” and “C”. One of the jumpers is only on a single pin. This is the “C” jumper. Remove this jumper.
 - g) Place the removed jumper across both “C” pins. At this moment, all four pins are covered.

Frequently Asked Questions

- h) Reconnect the phone line. Be careful not to touch any electronics inside the phone.
 - i) Press the call button on the front of the phone. Wait approximately 10 seconds. You may here some sounds from the speaker after you depress the call button, this is normal. The EEPROM is now reset to factory settings.
 - j) Disconnect the phone line. Remove the “C” jumper and return it to the way it was on just a single pin.
 - k) Reassemble the back box and cover plate.
 - l) You will have to reprogram the phone number(s) as well as any codes you programmed in the past. If you have a 400 Series phone, program *101* in order to use the long hang-up feature for compatibility with most phone systems.
- 5. Does the phone remember its programming if I unplug it?** Yes. All memory is non-volatile and does not require a back-up battery.
- 6. My phone doesn't have the ability to record a location identifier message. Can I get an upgrade?** Although existing units in the field cannot be upgraded with the "V" option, complete electronics modules (without faceplates) for every model are available with this feature. Call your distributor or Talk-A-Phone's sales department for more information about purchasing a new unit with the “V” option, or replacing the electronics of your existing unit.
- 7. Why doesn't my Keypad Emergency Phone autodial the number I programmed when I press the button?** The lower button on a standard keypad phone (the only button on a ETP-400KS and ETP-402KS) is used to take the phone off hook and get a dial tone. This button cannot be programmed to autodial. Model ETP-400DKV is available if you need a 2-button phone where the 2nd button can autodial and the keypad can be used for an IVR system.
- 8. How do I change the programming on an Emergency Phone when it is in “live” mode?** If you have programmed *78* into your phone, each subsequent time you call, the speaker and microphone on the unit will automatically be active. In order to enter programming mode (speaker and mic. will still be active, but quieter), hold down the * button for at least a second. You should hear one beep. Then enter your access code and begin programming as usual (For more information see Speaker and Microphone Codes, page 8).
- 9. My Emergency Phone is in an elevator with a highly reflective surface (e.g. glass or metal), is there anything I can do to improve the sound quality?** Below the speaker, there is a trimmer that controls microphone sensitivity. To adjust:
- 1. Remove the faceplate (if necessary)
 - 2. Pull out plugs and remove foam padding
 - 3. CAREFULLY adjust trimmer with a small flat-head screwdriver.

Note: The entire volume range is approx. 1/4 turn, please be careful.

VIII. Basic Trouble-Shooting

Problem	Possible Causes
My unit does not function at all. I cannot call it or call out on it.	<ol style="list-style-type: none"> 1. The phone wire is not properly connected. 2. Your unit has been struck by lightning or another very high voltage source. Contact Talk-A-Phone's Service Department. 3. There isn't enough power on the line (see Technical Requirements, page 3).
I can hear the guard, but the guard cannot hear me.	<ol style="list-style-type: none"> 1. The phone is on a PBX but is not programmed properly (see PBX/Configuration Codes, page 11). 2. The phone is on a PBX "ringdown" line that does not meet the power requirements (see Technical Requirements, page 2). 3. There is some other device on the line (e.g. auto-dialer, fax machine, etc.) 4. The phone is programmed to play a message upon answering but there is no message recorded. The guard hears 10 seconds of silence before 2-way communication. The code for disabling this message is *70* (see Intelli-Voice Option Codes, page 9).
I programmed in a message for the "V" option, but all the guard hears is silence.	<ol style="list-style-type: none"> 1. Your phone doesn't have the Intelli-Voice option (model number doesn't end in "V"). See FAQ #6, page 20.
My phone does not hang up.	<ol style="list-style-type: none"> 1. The phone is on a PBX but is not programmed properly (see PBX/Configuration Codes, page 11). 2. Your phone is on a PBX that doesn't provide a) a hang-up pulse and b) produces a re-order tone less than 30 seconds after hang-up. Consult the party responsible for maintaining your phone system.
The Intelli-Voice message begins playing before the guard answers the call.	<ol style="list-style-type: none"> 1. The phone is calling a local extension off a PBX and the phone system is "answering" the call before transferring it. Try programming the phone to get an outside line and call directly. For more information, consult the party responsible for maintaining your phone system. 2. The phone is programmed to call a number that then routes the call to another number. Try programming the phone to dial a number directly.
When the guard answers the phone he hears a series of tones before he can talk.	<ol style="list-style-type: none"> 1. The phone is transmitting its unique ID. If you are using an EB-100, EB-200, or Talk-A-Lert to identify the location of incoming calls, these tones are required. If not, the code for disabling this feature is *49*.
The phone gets dial tone, dials and then hangs up.	<ol style="list-style-type: none"> 1. There isn't enough power on the line (see Technical Requirements, page 2).
My auxiliary devices will not activate when I press *25* or *28*.	<ol style="list-style-type: none"> 1. The guard phone is on a PBX that does not produce the necessary tones. Try calling and activating the device from a standard phone line. 2. The auxiliary devices aren't properly installed (see Hardware Installation, page 4). 3. You must press * then *4** before pressing *25* or *28* to activate your device (or see Security Codes, page 8 to disable this feature). 4. You may have to enter * before pressing *25*

Basic Trouble-Shooting

<p>My device is connected to the auxiliary input wires but it does not activate the phone</p>	<p>1. If you have a newer phone, produced in 2012 or after, you will need model ETP-AUXIN-KIT. Please contact Talk-A-Phone to receive this kit at no charge.</p>
<p>My phone will not successfully dial the 2nd number if the first one is busy or not answered</p>	<p>1. Make sure you have programmed a secondary number in the *23* programming slot. 2. Try programming the long hang-up feature, *101*.</p>



For multiple phones to share one line, an EC-2 or EC-8 Consolidator is required.

IX. Talk-A-Phone Co. Limited Warranty

Equipment. Talk-A-Phone Co. warrants Talk-A-Phone equipment against any defects in material and workmanship, under normal use, for a period of twenty-four (24) months from date of installation, provided that Talk-A-Phone receives a completed "Installation Certification" certifying the date on which the system has been installed. An "Installation Certification" card is enclosed with every unit. In the event that no "Installation Certification" is received by Talk-A-Phone, the twenty-four (24) months will commence on the date of shipment by Talk-A-Phone. The warranty period for Models ETP-PM, ETP-MT, ETP-MT/R and WEBS-MT/R is five (5) years, under the same terms and conditions.

Services. In the event this product is found by Talk-A-Phone to be defective within the warranty period, Talk-A-Phone's only obligation and your exclusive remedy shall be the repair and/or replacement of any defective parts, provided the equipment is returned to Talk-A-Phone Co., 7530 North Natchez Avenue Niles, Illinois 60714-3804. It is expressly understood that Talk-A-Phone shall have no obligation to furnish labor, nor pay for the labor of any third parties, nor bear the expense of shipping defective products for repair.

Limitations/Exclusions. This warranty shall not apply if Talk-A-Phone determines that the defect was caused by the negligent or improper use of Talk-A-Phone's equipment, failure to follow operational and maintenance procedures outlined in the supplied manual, or damage caused to the equipment by unauthorized technicians.

THIS WARRANTY GIVES YOU SPECIFIC LEGAL RIGHTS AND YOU MAY ALSO HAVE OTHER RIGHTS WHICH VARY FROM STATE TO STATE.

Talk-A-Phone Factory Service. Talk-A-Phone's factory repair service is available to Talk-A-Phone's product owners at a reasonable charge, plus transportation to and from our factory. When returning units freight prepaid to our factory, Talk-A-Phone's technicians will examine, service and promptly return the units back to you, transportation collect.

You must receive a Return Materials Authorization (RMA) number from the Talk-A-Phone's service department prior to sending units in for repair. Contact Talk-A-Phone at 773-539-1100 for troubleshooting or to get a return authorization.

Talk-A-Phone also offers replacement components for most of our products to dealers and end users at a reasonable charge. When ordering, please give either the component part number or a brief description of the component's function and the model for which it is needed. Also please have your purchase order number ready and provide Talk-A-Phone's representative with your full name, address and telephone number for faster service.

Phone Line Specifications

X. Federal Communications Commission Information

This device has been granted a registration number by the Federal Communications Commission (FCC), under part 8 rules and regulations for direct connection to telephone lines. In order to comply with these FCC rules, the following instructions must be carefully read and applicable portions followed completely. These instructions must be provided to the consumer.

- A.** This equipment complies with part 68 of the FCC rules. A label located on an outside surface of this equipment contains, among other information, the FCC registration number and ringer equivalence number (REN). If requested, this information must be provided to the Telephone Company.
- B.** As indicated below, the suitable jack (USOC connecting arrangement) for this equipment is shown. If applicable, the facility interface codes (FIC) and service order codes (SOC) are shown.
- C.** The ringer equivalence number (REN) is used to determine the quantity of devices which, when connected to the telephone line, may result in the device not ringing in response to an incoming call. In most, but not all, areas, the sum of the REN's should not exceed five (5.0). To be certain of the maximum number of devices that may be connected to the line, as determined by the total REN's, contact the Telephone Company to determine the maximum REN for the calling area.
- D.** If this equipment (indicated with trade name and model) causes harm to the Telephone Network, the Telephone Company will notify you in advance. If advance notice is not practical, the Telephone Company will notify the customer as soon as possible. Also, you will be advised of your right to file a complaint with the FCC if you believe it is necessary.
- E.** The Telephone Company may make changes to its facilities, equipment, operations or procedures that could affect the operation of this equipment. If this happens, the Telephone Company will provide advance notice in order for you to make the necessary modifications needed in order to maintain uninterrupted service.
- F.** If trouble is experienced with this equipment, (indicated below with trade name and model, together with a service center in the U. S. A. address and telephone number), contact the manufacturer for repair and/or warranty information. If the trouble is causing harm to the Telephone Network, the Telephone Company may request that you remove the equipment from the Network until the problem is resolved. User repairs must not be made. Doing so voids the warranty.
- G.** This equipment must not be used on Telephone Company provided public coin service. Connection to party lines is subject to State Tariffs, (contact your State Public Utility Commission for information). If so required, this equipment is hearing aid compatible (HAC).
- H.** The user is cautioned that any changes or modifications not expressly approved by the party responsible for compliance could void the user's authority to operate the equipment.

Federal Communications Commission Information

- I. The Talk-A-Phone Co. U. S. A. Service Center is located at 7530 North Natchez Avenue, Niles, Illinois 60714-3804, telephone number (773) 539-1100, fax number (773) 539-1241.

XI. Phone Line Specifications

A. MODE I Operation

The following criteria must be met by a phone line to insure proper functionality of the FCC approved equipment. All voltages use Tip as ground when measuring.

1. On-Hook voltage must be less than or equal to -36 V (-50 V standard).
2. Off-Hook should be recognized in a maximum time of 300 ms.
3. At an Off-Hook voltage of -15 V , the current that is supplied must be no less than 20 mA and no more than 120 mA.
4. Dial tone must consist of 350 Hz and 450 Hz tones at $-17\text{ dB} \pm 0.5\%$.
5. The telephone line must generate Ring-Back consisting of 440 Hz and 480 Hz tones at $-17\text{ dB} \pm 0.5\%$, with a duty cycle of 1.6 seconds on—4.8 seconds off $\pm 10\%$ interrupted at 20 Hz.
6. The telephone line must generate a busy signal consisting of 480 Hz and 620 Hz tones at $-17\text{ dB} \pm 0.5\%$, with a duty cycle of 500 ms on—500 ms off.
7. The telephone line must be able to recognize or send the following frequencies in order to decode or transmit DTMF:
 - a) 685 Hz — 709 Hz Row 1
 - b) 757 Hz — 784 Hz Row 2
 - c) 837 Hz — 867 Hz Row 3
 - d) 925 Hz — 957 Hz Row 4
 - e) 1189 Hz — 1229 Hz Column 1 (1, 4, 7, *)
 - f) 1314 Hz — 1358 Hz Column 2 (2, 5, 8, 0)
 - g) 1453 Hz — 1501 Hz Column 3 (3, 6, 9, #)
 - h) 1607 Hz — 1659 Hz Column 4 (A, B, C, D)
8. When dialing, the telephone line should require a minimum tone pulse ON time of 40 ms, as well as a minimum between tone gap of 40 ms.
9. The telephone line should support and match with a 600W AC impedance, as well as a DC resistance of 100 W — 200 W.
10. The telephone line should recognize a 450ms hang-up as a disconnect signal.

B. MODE II and MODE III Operation

Talk-A-Phone phones can be used with most PBX systems with non-standard dial tones, ring-backs, busy signals and hang-ups.

Phone Line Specifications

XII. Information To The User

A. Section 15.105

This equipment has been tested and found to comply with the limits for a Class B Digital Device, pursuant to Part 15 of the FCC rules. These limits are designed to provide reasonable protection against harmful interference in a residential installation. This equipment generates, uses and can radiate radio frequency energy, and may cause harmful interference to radio communications if not installed and used in accordance to the instructions. However, there is no guarantee that the interference will not occur in a particular installation. If this equipment does cause harmful interference to radio or television reception, which can be determined by turning the equipment off and on, the user is encouraged to try to correct the interference by one or more of the following measures:

1. Reorient or relocate the receiving antenna;
2. Increase the distance between the equipment and the receiver;
3. Connect the equipment into an outlet on a circuit different from that to which the receiver is connected;
4. Consult the dealer or an experienced Radio/TV technician for assistance.

B. Section 15.21

The user is cautioned that any changes or modifications not expressly approved by the party responsible for compliance could void the user's authority to operate the equipment.

C. Section 15.27

The user is cautioned that any peripheral device installed with this equipment, such as a modem or printer, must be connected with a high-quality shielded cable to insure compliance with FCC limits.

XIII. Maintenance

A. Testing

It is recommended to periodically test the functionality of an Emergency/Information Phone to ensure it is operational. You should consult your security service provider about the necessity of such tests and their frequency. Optionally, Talk-A-Lert polling software can be utilized to verify connections and basic functioning of all existing Emergency/Information Phones on a regular basis.

B. Cleaning

It is recommended to periodically clean the surface of the Emergency / Information Phone with a cleanser or a cleanser and water mixture. If it is safe to use on glass, it is usually safe to use on stainless steel. Wipe the plate dry when finished.

Federal Communications Commission Information

Inspect the equipment frequently. If you notice discoloration, tarnish or water stains, increase the frequency of your cleanings. You can also try cleaning with borax, soda ash, or a non-abrasive commercial cleanser and water. Deeper stains may be removed with a magnesium oxide, ammonia and water paste. Wipe clean with water rinse and dry the plate.

Light rusting on the faceplate can be removed with a stronger cleaning agent, such as Simichrome Polish. For stronger corrosion, naval jelly is recommended. To remove or reduce pitting damage caused by corrosion, mechanical polishing is preferred to chemical cleansing. Scotchbrite works well for this purpose. Work only in the direction of the existing grain and never use steel wool.

Please refer to ASTM A-967 and ASTM A-380 guidelines regarding stainless steel passivation and maintenance.

C. Preventative Maintenance

For most installations the stainless steel finish does not require any maintenance to prevent the occurrence of corrosion. In rare cases, e.g. high humidity environment, exposure to airborne contaminants or direct contact with certain chemical compounds like salt spray, it may be required to perform preventative maintenance on a regular basis.

A regular automotive wax can be used to prevent corrosion of the stainless steel. Follow these directions to reinforce the chromium oxide layer on the faceplate and prevent it from further corrosion:

- Wet a cleaning pad with fresh water (do not use chlorine water) and apply powered cleanser;
- Using gentle pressure, rub stained areas in the same direction of the existing polishing grain until stains are removed;
- Rinse with clean water. Use cleaner de-greaser to remove any stains;
- Thoroughly dry the stainless steel faceplate;
- Apply a layer of an automotive wax on the faceplate and wait until it dries out to a haze;
- Buff the wax in with a soft dry cloth until the residue is gone.

DO NOT use steel wool, sandpaper, mineral acids, bleaches, or chlorine cleansers on the stainless steel surface.

PHONE INFORMATION

Model # _____

1. To Reach This Unit, Call This Number: _____

2. Phone Location: _____

3. Type of Communication Line: _____ Telephone Company

_____ PBX Extension

4. Primary Phone Number Called: _____

5. Secondary Phone Number Called: _____

6. Intelli-Voice ("V" Option): _____ Yes _____ No

7. PBX Ring-Down: _____ Yes _____ No

8. PBX Prefix (If Needed): _____

9. Auxiliary Devices (If Used)

Input(s): _____

Output #1: _____

Output #2: _____

10. Consolidator Port (If Used): _____

Installation Date: _____

NOTES

Talk-A-Phone Co.

7530 North Natchez Avenue Niles, Illinois 60714-3804

Phone: (773) 539-1100 Fax: (773) 539-1241

e-mail: info@talkaphone.com <http://www.talkaphone.com>