

INSTALLATION INSTRUCTIONS

DTK-ESS (Electric Switch Suppressor)

The Ditek DTK-ESS kit is intended for use on electrical switching devices that are connected through or that are actuated by a relay contact on access control panels. The DTK-ESS kit consists of 2 suppressors. 1- protects the control panel, the 2nd protects the relay contacts. Both protect against transients that are the result of the collapsing electrical field of an electromagnetic switching device. Like that of an electric door strike.

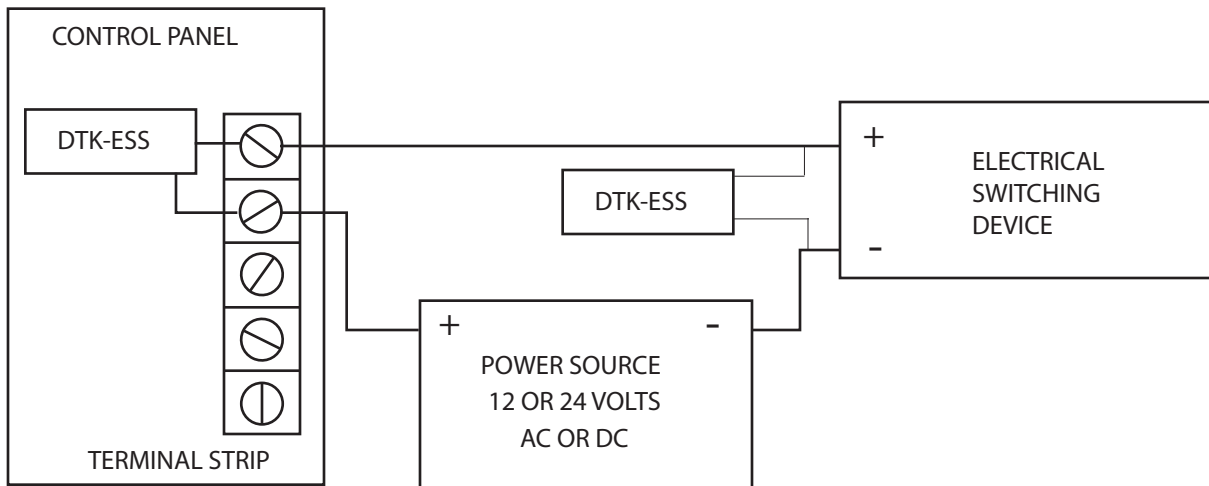

Each electrical switching device will require 1- suppressor to be installed across the relay contacts located at the control panel, and the 2nd suppressor to be installed across the leads of the switching device solenoid. The DTK-ESS is a bipolar device and can be installed without regard to polarity.



Diversified Technology Group, Inc.

1720 Starkey Road Largo, Florida 33771

Tel. 727-812-5000 Fax 727-812-5026

SCALE:	APPROVED BY:	DRAWN BY: RWM
DATE: 6-24-99		REVISED:
DESCRIPTION: INSTALLATION INSTRUCTION, DTK-ESS	PART NO. 191398	REV. 0
MATERIAL: FINISH:	DRAWING NUMBER INT-100047-001	