

## STEP 1

- \* Measure door opening height from finished floor to bottom of header.
- \* Subtract 1 1/8" from door opening dimension to get length of mullion.
- \* Measure and cut mullion to size.

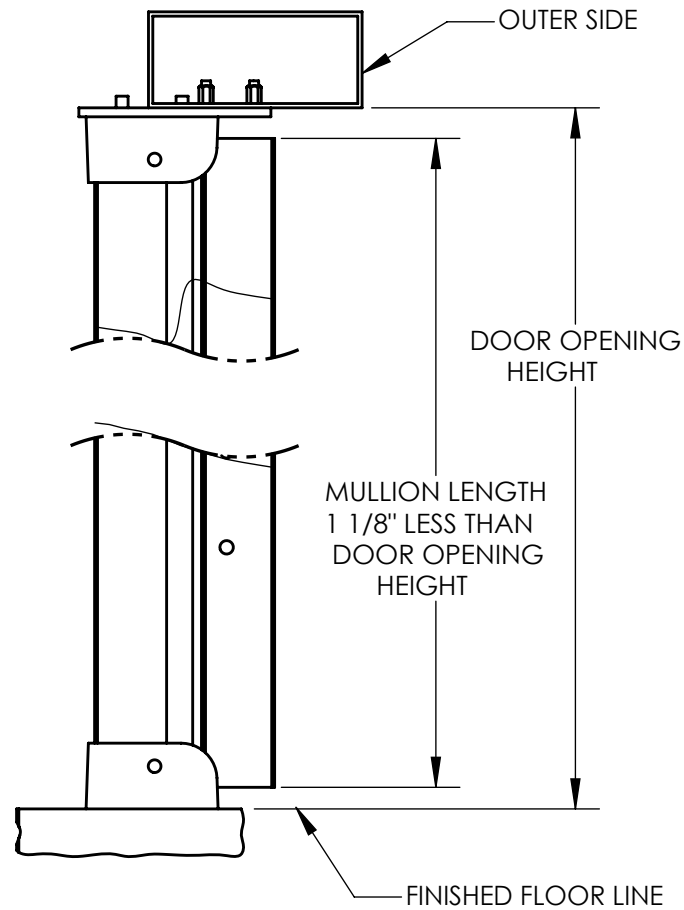

## STEP 2

- \* Use mounting plate as a template to drill three 1/4" dia. holes for 10-32 rivnuts lining up centerlines as shown in fig. 1.
- \* Install mounting plate with three 10-32 x 3/4" flat head screws.
- \* Install top fitting on mounting plate using two 1/4-20 x 3/4" pan head machine screws.

This dimension is used when the door is flush with the outside of the header. If this is not the case add the distance that the door is moved inward from the face of the header to this dimension.

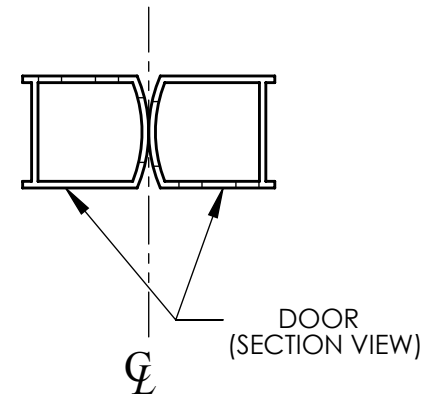
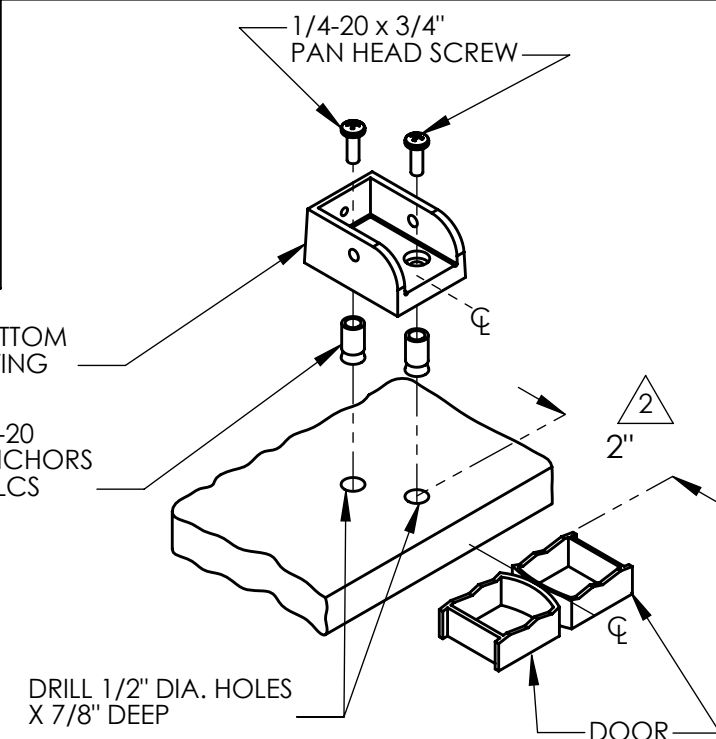
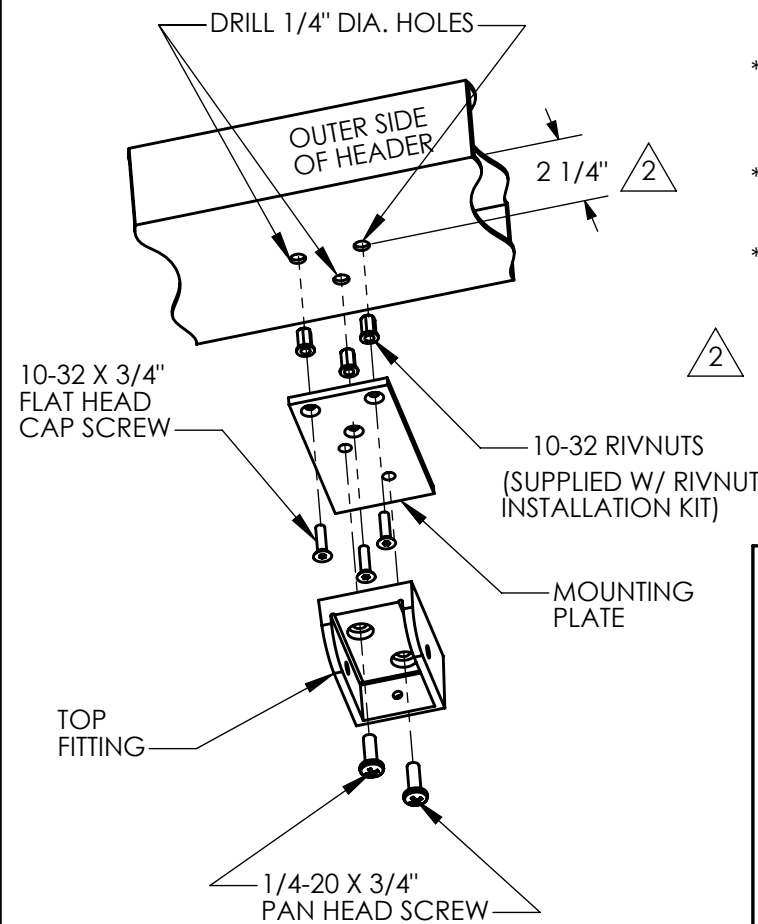
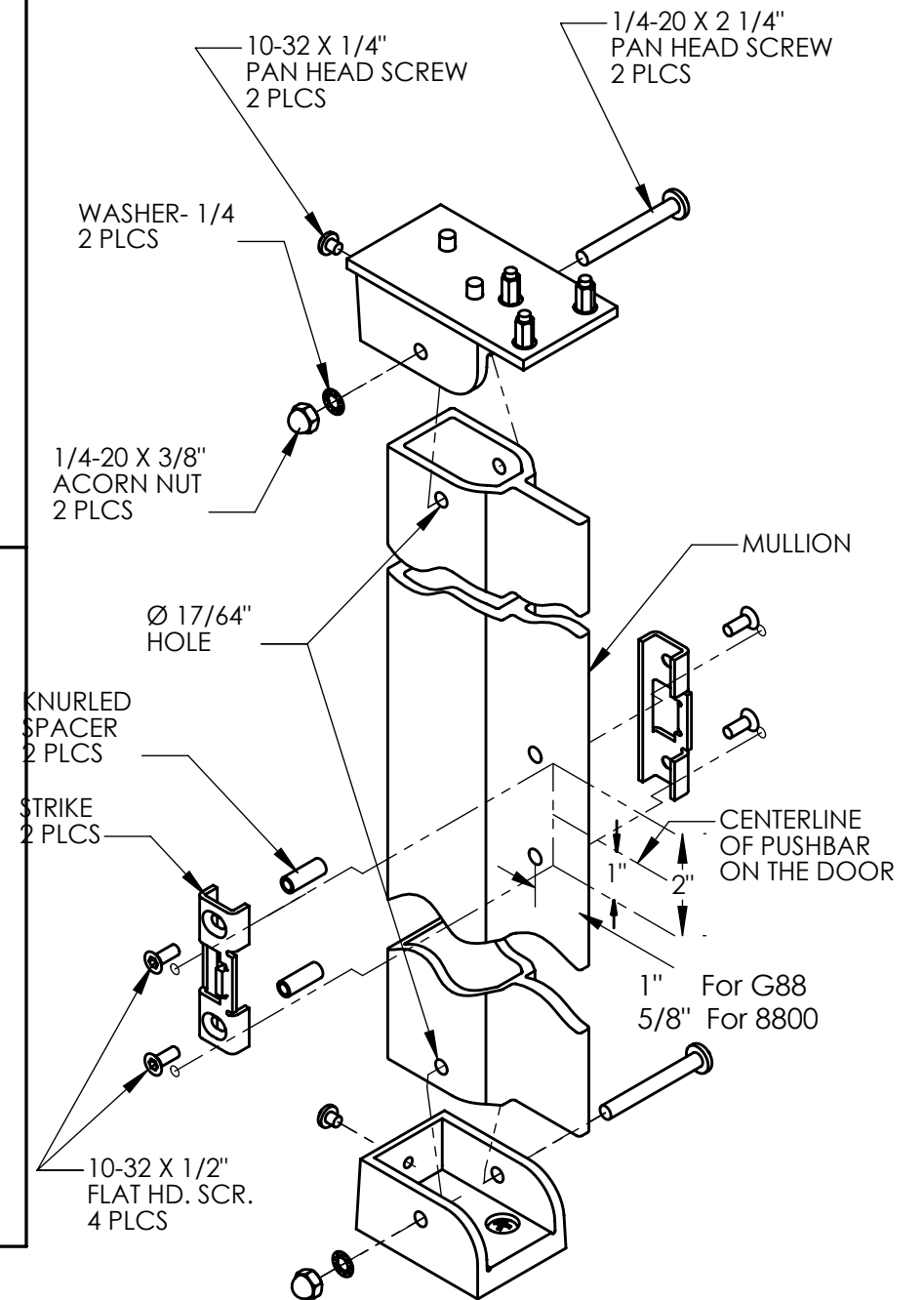

FIG. 1

## STEP 4

- \* Slide mullion into top and bottom fittings.
- \* Drill two 17/64" dia. holes through mullion using top and bottom fitting holes as guide.
- \* Insert 1/4-20 x 2 1/4" pan head screw through holes in fittings and mullion.
- \* Slip toothed washer onto screws and secure with 1/4-20 x 3/8" acorn nuts.



## STEP 3

- \* Use the bottom fitting as a template and place it on the floor against the doors lining up on centerlines.
- 1 The bottom fitting is in line with the top fitting.
- \* Mark and drill two 1/2" dia. holes by 7/8" deep.
- \* Insert two 1/2" dia. zinc anchors and mount bottom fitting with two 1/4-20 x 3/4" pan head mach. screw.

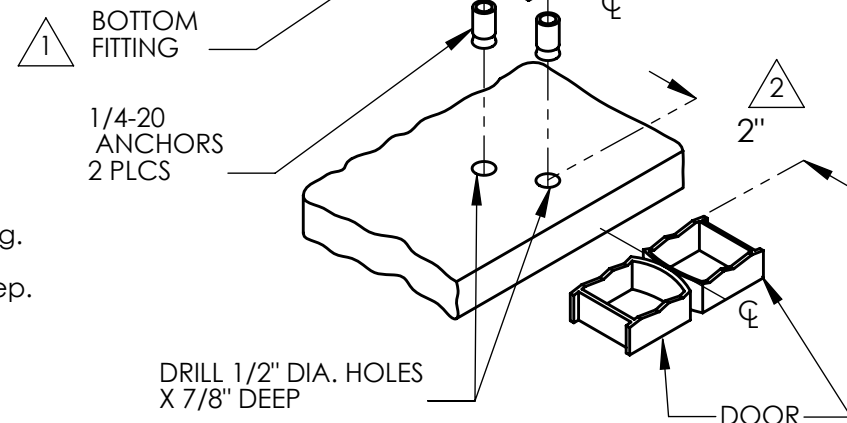

- \* Install & tighten the two 10-32 x 1/4" pan head screws into the rear of both fittings to stabilize the mullion.
- \* To install the strikes, drill two 9/32" holes through mullion at the pushbar centerline and insert knurled spacers.
- \* Mount the strikes to the mullion using four 10-32 X 1/2" flat head cap screws.



www.adamsrite.com  
Phone: 800-626-7590  
800-872-3267

Fax: 866-582-4641  
800-232-7329

3890 REMOVABLE MULLION FPR ALUMINUM DOORS

80-0180-219

Rev. E

ECN: 11955C

Date: 07-10-12

Page 1 of 1 Appvd: MP Date: 07-19-12

ASSA ABLOY