

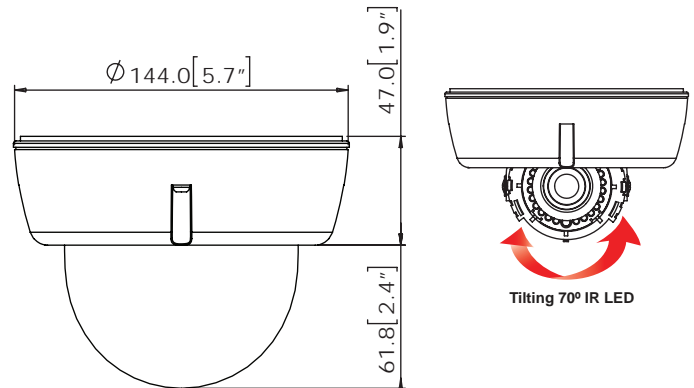

**Dimensions (unit : mm)**



**Summary**

Our Starlight 960H Series is a combination of our powerful Starlight Super-Low Light technology and a 960H CCD image sensor. This combination allows our cameras to achieve higher resolution and higher sensitivity to light than conventional CCTV cameras. Our Star-Light technology offers a slow shutter feature that increases the length of time the shutter remains open to collect additional ambient light, illuminating typically dark environments. Together with the 960H CCD sensor, the camera produces a clear horizontal resolution of up to 720 TV lines.

**Features**

- 960H 1/3" CCD Image Sensor (960 Horizontal Pixels)
- 720 TV Lines [B/W], 700 TV Lines [Color]
- 3.6mm Fixed Lens
- 100ft Range IR with Intelligent Camera Sync, Smart IR
- Electronic Day & Night
- Star-Light (Super Low Light Technology)
- 3D DNR (3D Digital Noise Reduction)
- Star-Light (Super Low Light Technology)
- HME (Highlight Masking Exposure)
- SLC (Side Light Compensation)
- Programmable Privacy Zones (8) & Motion Detection
- AGC / BLC / AWB
- IP66 Certified (Weatherproof)

**Specifications**

VIDEO	
Image Sensor	960H 1/3" CCD
Total Pixels	960 (H) x 478 (V)
Scanning System	2 : 1 Interlace
Frequency	15.734KHz (H), 59.95Hz (V)
Synchronization	Internal or Line Lock
Horizontal Resolution	720 TV Lines [B/W], 700 TV Lines [Color]
Minimum Illumination	F1.2 (30IRE): 0.0 Lux
S/N Ratio	52dB (AGC off)
Video Output	CVBS: 1.0Vp-p / 75 Ω
LENS	
Focal Length	3.6mm
Lens Type	Fixed Lens
IR Distance	100ft Range IR
OPERATIONAL	
Shutter Speed	1/60s-1/120000s
Backlight	OFF / ON
Star-Light	X2 - X512
3D-DNR	OFF / Low / Middle / High
White Balance	ATW/ PUSH/ MANUAL
Day and Night	Auto / Day / Night
Mirror	OFF / V. Flip / Rotate
Auto Gain Control	1 ~ 20
Gamma	0.35 ~ 0.7
Motion Detection	4 Motion Regions
Privacy Zones	8 Programmable Privacy Masks
Dynamic Range Compressor	OFF / Low / Middle / High
Sharpness	0 ~ 20
Highlight Masking Exposure	OFF / Low / Middle / High
DPC (Dead Pixel Cancellation)	OFF / ON
ENVIRONMENTAL	
Operating Temperature	-10°C ~ 50°C (14°F ~ 122°F)
Operating Humidity	Less than 90% (Non-Condensing)
IP Rating	IP66 (Protects against dust and high pressure water.)
ELECTRICAL	
Power Requirement	DC12V
Power Consumption	DC12V: 1.8W, 150mA, LED On: 4.3W, 358mA
MECHANICAL	
Housing Material	Aluminum
Dimensions	145 x 108.8 mm (5.7 X 4.28 in)
Weight	1.65 lbs

\*Specification is subject to change without prior notice.

**Accessories (Optional)**



DWC-V1CM  
Pendant Mount for V1, V3 & V6 Housing



DWC-V1WM  
Wall Mount for V1, V3 & V6 Housing

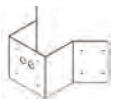

DWC-V1CNM  
Corner Mount for V1, V3 & V6 Housing



DWC-V1JUNC  
Junction Box for V1, V3 & V6 Housing