



D-TEK™

Vehicle Loop Detector



Operating Instructions



This product is an accessory or part of a system. Always read and follow the manufacturer's instructions for the equipment you are connecting this product to. Comply with all applicable codes and safety regulations. Failure to do so may result in damage, injury or death!

Product Overview

The D-TEK™ Vehicle Loop Detector allows for detection of metallic objects entering into the field formed around the detection loop. We have designed the D-TEK with the following objectives in mind:

1. Compact package to allow easy installation into small operator housings.
2. All controls are accessible from the outside for easy installation and operation.
3. Integral loop conditioner is provided, to enable detector operation with marginal loops.
4. Provide all features and controls necessary for a variety of applications.
5. Use metal housing for maximum durability and RF resistance.
6. Provide maximum surge protection on all inputs and outputs of the detector.

We took extra care to achieve and exceed these objectives. For example the controls are divided into two groups. The group on the front of the detector is for basic operation and the group on the back of the detector is for advanced settings. This way the more advanced settings are not visible to the casual user.

The D-TEK is made from aircraft quality anodized aluminum and all switches have gold plated contacts that are sealed for protection. The circuit is protected by an advanced thermal resettable fuse, snubbing circuitry on the relay contacts, Metal Oxide Varistor on the power input and triple protection on the loop input.

The D-TEK features are extensive and include full loop diagnostic with frequency counter, 10 sensitivity settings, delay and extend features, :fail safe and “fail secure” operation, automatic sensitivity boost, pulse or two presence relay operation and more.

Technical Specifications

Power Supply	12 Volt DC, 24 Volt AC, 24 Volt DC, 120 Volt AC, 220 Volt AC
Power Supply Tolerance	+/- 20% of power rating
Current Draw	100 mA maximum
Housing Material	Extruded Anodized Aluminum H=3.25" (83mm), W=2.56" (40mm) D=3.65" (90mm)
Relay Type	(2) DPST 5A@ 125VAC
Temperature Range	-40 to 180 Degrees Fahrenheit
Connector	11 Pin Octal compatible with DIN rail mount socket or wire harness
Loop Inductance Range	20 to 2000 micro henries with "Q" factor of 5 or higher
Loop Input	Transformer Isolated
Power On Indicator	Green T-1 LED
Detect Indicator	Red T-1¾ LED
Surge Protection	MOV, Neon and Silicon Protection Devices
Tuning	Detector automatically tunes to the loop after power application or reset
Tracking	Detector automatically tracks and compensates for environmental changes
Environmental Protection	Circuit board is conformal coated to resist moisture
Frequency Counter	Counts Loop frequency, each blink represents 10KHz. Counts between 3 to 13 blinks confirm that the detector is tuned to the loop.
Power Indicator	Solid lighted green LED indicates power
Loop Failure Indicator	Slow blinking green LED indicates loop failure
Loop Failure Memory	Fast consecutive green blinking LED indicates past loop problem that healed
Detect Indicator	Solid lighted red LED indicates detection
Extend Indicator	Blinking red LED after vehicle leaves the loop indicates time extend
4 minute limit	Blinking red LED during vehicle detection indicates that 4 minute limit has expired.

Controls, Indicators and Connections

Front

POWER	LED
Green T-1 Glows when power is applied	
DETECT	LED
Red T-1¾ Glows to indicated detection	
FREQUENCY COUNTER	Momentary Switch
Pull up toward Power LED and release	
RESET	Momentary Switch
Push down toward Freq. and release	
FREQUENCY	Three Position Switch
Low, High, Medium Unit must be reset after any change!	

Back

SENSITIVITY	BCD Switch
0,1,2,3,4,5,6,7,8,9 must be on a number	
DIP SWITCH FUNCTIONS	Dip Switch
OFF	ON
1 Pulse on Relay 2	Presence on Relay 2
2 Pulse on Detect	Pulse on Un-detect
3 Constant Presence	4 minute limited presence time
4 "Fail Secure"	"Fail Safe"
5 Filter OFF	Filter On
6 ASB OFF	Automatic Sensitivity Boost
7 Extend Detect	6 seconds
8 Extend Detect	3 seconds
DIP 7 & 8 ON Extend time is 9 seconds	

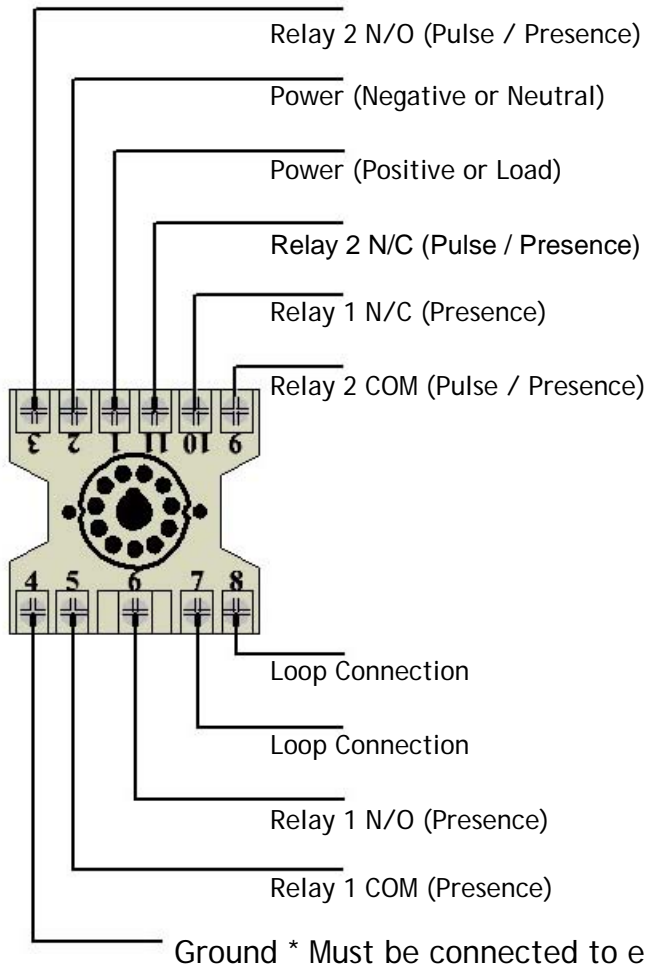

CONNECTIONS		86CP11 PIN CONNECTOR
PIN	FUNCTION	HARNESS
1	POWER +	WHITE
2	POWER -	BLACK
3	RELAY 2 N/O (PULSE OR PRESENCE)	ORANGE
4*	GROUND *	GREEN
5	PRESENCE RELAY (1) COM	YELLOW
6**	PRESENCE RELAY (1) N/O	BLUE
7	LOOP	GRAY
8	LOOP	BROWN
9	RELAY 2 COM (PULSE OR PRESENCE)	RED
10**	PRESENCE RELAY (1) N/C	PINK
11	RELAY 2 N/C (PULSE OR PRESENCE)	VIOLET

* **NOTE:** Pin 4 must be connected to earth ground for surge protection to be effective.
 ** **NOTE:** Functions on pins 6 and 10 are reversed if DIP switch 4 is set to OFF "Fail Secure" operation

Installation

1. Connect the D-TEK to appropriate power supply as marked on the label of the detector on pins 1 and 2 according to the connection chart on page 3 of this manual.
2. Connect the loop wires to pins 7 & 8 (Brown and Gray wires in harness) The D-TEK must be connected to a loop meeting the appropriate requirement listed on page 2.
3. Connect the desired relay outputs to the operator control board inputs. Relay 1 is a "Constant Presence" and Relay 2 is "Pulse" or "Constant Presence".
4. Adjust sensitivity to desired level to assure detection of all vehicle traffic. Factory set is normally 3 or 4.
5. Pin 4 (GREEN WIRE) must be connected to earth ground for effective surge protection.
6. Do not install the loop wire near or parallel to:
 - a. Low voltage lighting.
 - b. Telephone lines.
 - c. Underground power lines.
 - d. Electrical pavement heaters.
 - e. Cell phone towers or radio communication systems.
 - f. Overhead power lines.
 - g. Transformers.
7. To install the loop into new concrete with re-bar or wire mesh we recommend that the loops be installed at least 1 inch above the re-bar.
8. When installing in saw cut we recommend the use of backer rod and a good grade sealant for the type of surface.

Operational settings explained

1. **Reset Switch**- when this toggle switch is momentarily pressed down toward the "Frequency Switch" and released will cause the D-TEK to reboot.
2. **Frequency Switch**- this 3 position toggle switch is used to change the loop operation frequency to High/Medium or Low. This helps to prevent cross talk with adjacent loops and possible interference from other sources in the same operational frequency. Note: When the frequency is changed the D-TEK must be re-set.
3. **Frequency Counter**- when this toggle switch is momentarily pushed up toward the power and detect LEDs will cause the detector to blink the red "Detect" LED. Each blink of the LED indicates a frequency multiple of 10 KHz. (example 5 blinks = 50 KHz.) Counts from 3 to 13 confirm that the detector has tuned to the loop.

-
4. **Sensitivity**- this rotary switch controls the detector sensitivity. During normal operation the sensitivity setting is 3 or 4. Note: the higher the sensitivity the more prone the detector will be to interference. To increase detection height without increasing the detector sensitivity settings, increase the size of the loop. Detection height is roughly 70% of the shortest side of the loop. (example 4 x 8 loop = approximately 33 inch detection height and a 6 x 8 loop = approximately 50 inch detection height.)
 5. **ASB**- Automatic Sensitivity Boost is activated by DIP switch 6 on the back of the detector. This allows the detector to be set at a "standby" sensitivity and when detection occurs sets the sensitivity to maximum until the unit un-detects. This allows for the use on high bed vehicles that might otherwise un-detect while still in the loop.
 6. **Pulse/Presence relay 2**- this feature is controlled by DIP switch 2 on the back of the detector and allows relay 2 to act in the pulse mode or as a second presence mode relay mimicking relay 1.
 7. **Pulse Detect/Un-detect**- this feature is controlled by DIP switch 2 on the back of the detector. Allows for activation on entering into the loop or exiting from the loop.
 8. **Constant Presence / 4 minute limit**- this feature is controlled by DIP switch 3 on the back of the detector and allows for the detector to hold the activation for as long as any vehicle is in the detection loop or to allow the relay to de-activate after 4 minutes. **Warning!** DO NOT USE 4 minute limit unless opening is protected by a secondary safety device such as the IRB-4X.
 9. **Fail Safe / Fail Secure**- this feature is controlled by DIP switch 4 on the back of the detector. Normal factory setting is "Fail Safe" which allows the detector to hold the gate open in the event of a failure or loss of power on the detector. "Fail Secure" setting will force the detector to not change states on power loss or power up. **Warning!** This setting should not be used for safety reversing of gates, doors or barriers. **Note:** Function output on pins 6 and 10 are reversed if DIP switch 4 is turned off.
 10. **Filter**- this function is controlled by DIP switch 5 on the back of the detector. This feature inputs a momentary delay into the detection circuit to verify that a vehicle is present in the loop for a minimum time period before activation occurs.
 11. **Extend Detect**- this feature is controlled by DIP switches 7 and 8 on the back of the detector. Turning on switch 7 allows for a 6 second extension of the detection after the vehicle leaves the loop. Turning on switch 8 allows for a 3 second extension of the detection after the vehicle leaves the loop. Turning on both switches 7 and 8 allows for a 9 second extension of the detection after the vehicle leave the loop.

TROUBLE SHOOTING GUIDE

SYMPTOM	POSSIBLE CAUSE	SOLUTION
Green Indicator is not lit	No input voltage	<ol style="list-style-type: none"> 1. Check voltage on pins 1 and 2. 2. Check wiring to detector. 3. Verify voltage used matches voltage marked on unit.
Green Indicator flashes	Loop wire shorted or disconnected	Check loop resistance on pins 7 and 8, it should be less than 5 ohms and more than 0.5 ohms.
Green Indicator flashes with two consecutive fast blinks	Loop wire was temporarily shorted or disconnected	Check loop resistance on pins 7 and 8, it should be less than 5 ohms and more than 0.5 ohms. The reading should be steady.
Detector stays in detect mode after the vehicle leaves the loop and fails to un-detect.	<ol style="list-style-type: none"> 1. Faulty Loop. 2. Poorly crimped connections 3. Loose connections 	<ol style="list-style-type: none"> 1. Perform megger test between loop lead and ground, the reading should be greater than 100 Mega ohms. 2. Check that loop is tightly connected to proper terminals 3. Check that splices are tightly soldered and sealed against moisture
Detector detects intermittently even when there is no vehicle on the loop.	<ol style="list-style-type: none"> 1. Faulty Loop 2. Poorly crimped terminals 3. Loose connections 4. Cross-talk between adjacent loop detectors 5. Loop not securely installed to prevent movement of wire in pavement 	<ol style="list-style-type: none"> 1. Perform megger test between loop lead and ground, the reading should be greater than 100 mega ohms. 2. Check that loop is tightly connected to terminals 3. Check that splices are tightly soldered and sealed against moisture. 4. Set adjacent loops to different frequencies. 5. Verify that loop is securely installed in pavement and that site is in good condition preventing movement of loop wires.

Ordering Information

D-TEK-12	12 Volt DC powered detector
D-TEK-24	24 Volt DC powered detector
D-TEK-24A	24 Volt AC powered detector
D-TEK-110	120 Volt AC powered detector
D-TEK-220	220 Volt AC powered detector
D-TEK-MS	120 Volt AC powered detector with threaded connector
D-TEK-Q	120 Volt AC powered detector compatible pin out for

Accessories

PR-XX	EMX Lite-preformed loop with 50 ft. lead wire standard (XX = loop size example 48 = 4x8)
HAR-11	11 wire harness with 3 ft. of wire
LD-11	11 pin DIN rail socket

Installer notes:

Voltage installed:

DIP switches turned on:

Sensitivity setting:

Frequency setting:

EMX

INDUSTRIES, INC.

4564 Johnston Parkway
Cleveland, Ohio 44128
United States of America

WEB <http://www.emxinc.com>

Sales Telephone: (216) 518-9888

E-mail salesupport@emxinc.com

Technical Support Telephone (216) 834-0761

E-mail: technical@emxinc.com

