

DESCRIPTION



The **DP38-C Main Intercom Controller** is the 3rd Generation DoorBell Fon interface – the “brain” of the DoorBell Fon system. This product allows users to answer a door or gate from any telephone in their home or business. This 3rd generation controller can handle up to 4 different doors, is chock-full of features, and is upgradeable to open doors or ring door chimes.

Operation is simple. No programming! No codes! Just answer the phone like a regular telephone call!

APPLICATIONS

- Talk to visitors at your door with your phone
- Door Stations can be placed at:
 - Front/Rear Entrances
 - Remote Entryways
 - Marine Docks
 - Delivery Docks
 - Secured Facilities
 - Senior Housing
 - Disabled Housing
 - Apartment Complex
- Use with DP38-SW to open the door or gate with the phone
- Use with DP38-CI to use chimes, lights, or cameras

FEATURES

- Built-in call waiting
- Simple wiring procedure
- Plugs into any AC wall outlet
- 4 available Door Station terminals
- Each Door Station has a distinctive ring
- Available upgrades for more features:
 - DP38-SW
 - DP38-CI
- Compatible with any DoorBell Fon Door Station
- Compatible with VoIP lines
- Phone-to-phone intercom
- Call transferring
- Automatic queuing

SPECIFICATIONS

Power Requirements:

- 24 VDC/ 600mA
- **Fuse 1:** 250VA, 0.25A, GFE
- **Fuse 2:** 250VA, 1A, GFE

Output:

- 17-28 VDC (Voice)
- 750Vrms/25 +/- 2Hz (Ringing)

Operating Temperature:

- -20 F to +120 F

Dimensions:

- 5.5” x 5.75” x 1.75”

Shipping Weight:

- 2.1 lbs

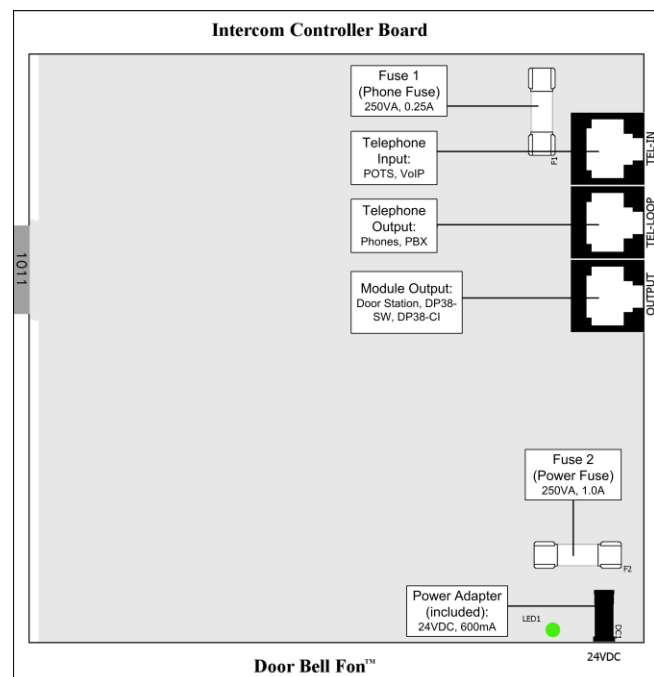

Quick Installation Guide

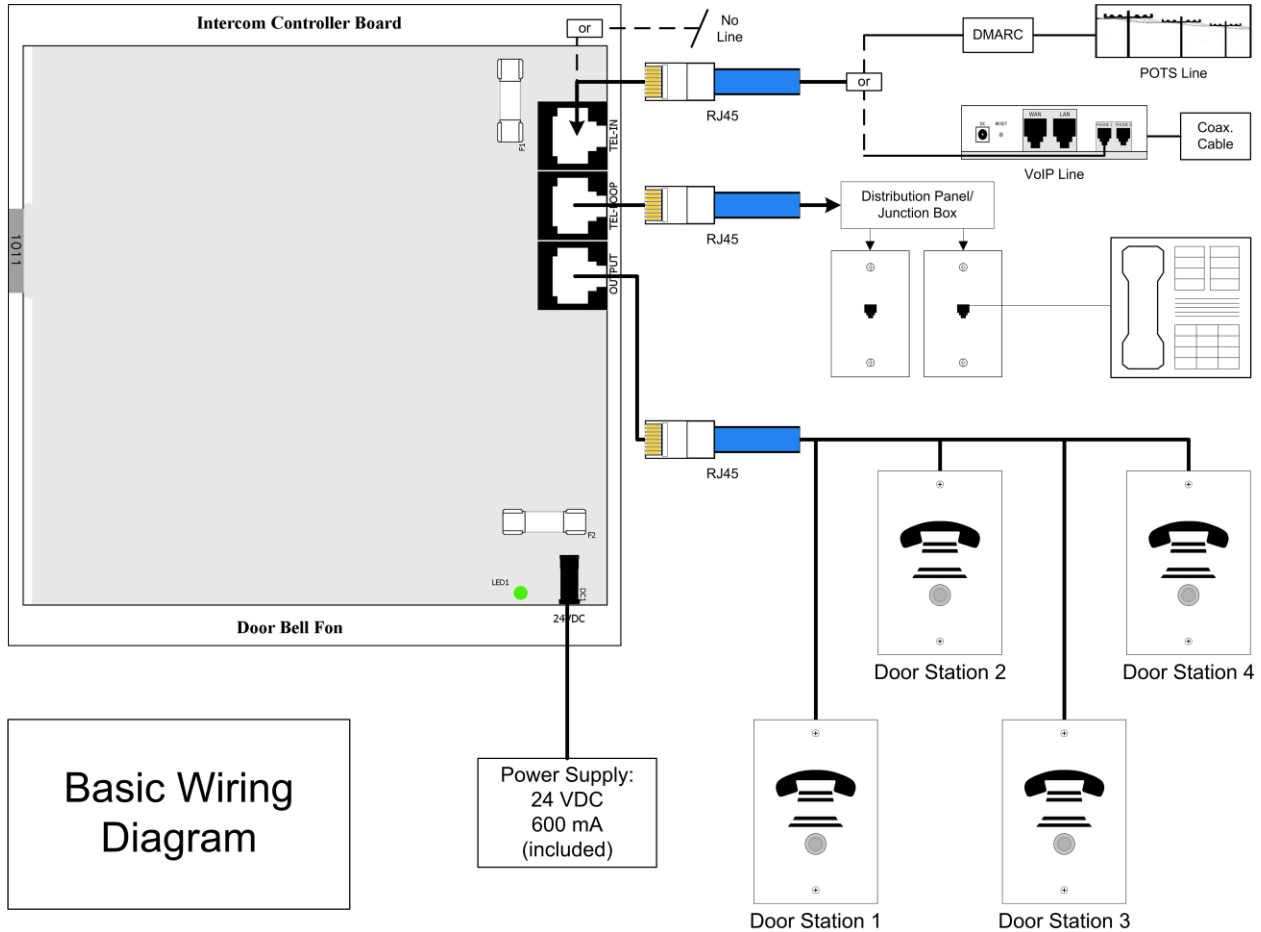

Basic Wiring Diagram

1. Connect the incoming phone line from the Telephone Company (or VoIP modem/router) to TEL-IN of the DoorBell Fon Intercom Controller Board using an RJ45 plug on one end with CAT5/CAT5e. If no telephone service is available, continue on to step 2. Telephone service is not necessary.
2. Connect TEL-LOOP to all the phones in the house using an RJ45 plug on one end with CAT5/CAT5e. If using PBX, leave TEL-IN empty and connect TEL-LOOP to a FXO port/Trunk line.

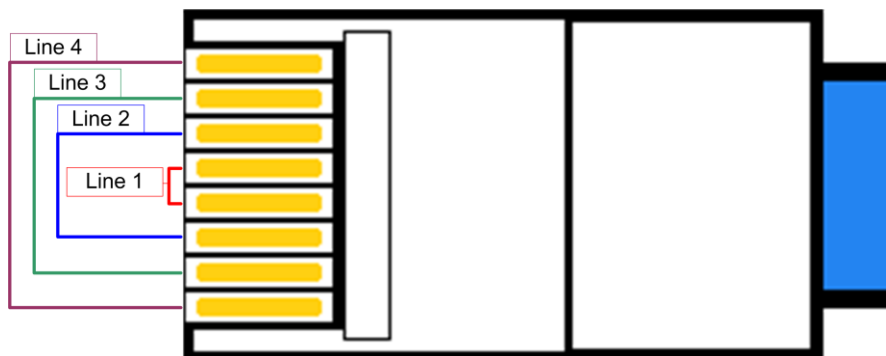

*Note: Line 1 is the only line that the DoorBell Fon utilizes. Other lines simply pass through.

- Connect OUTPUT to your Door Station(s) using an rj45 plug on one end.

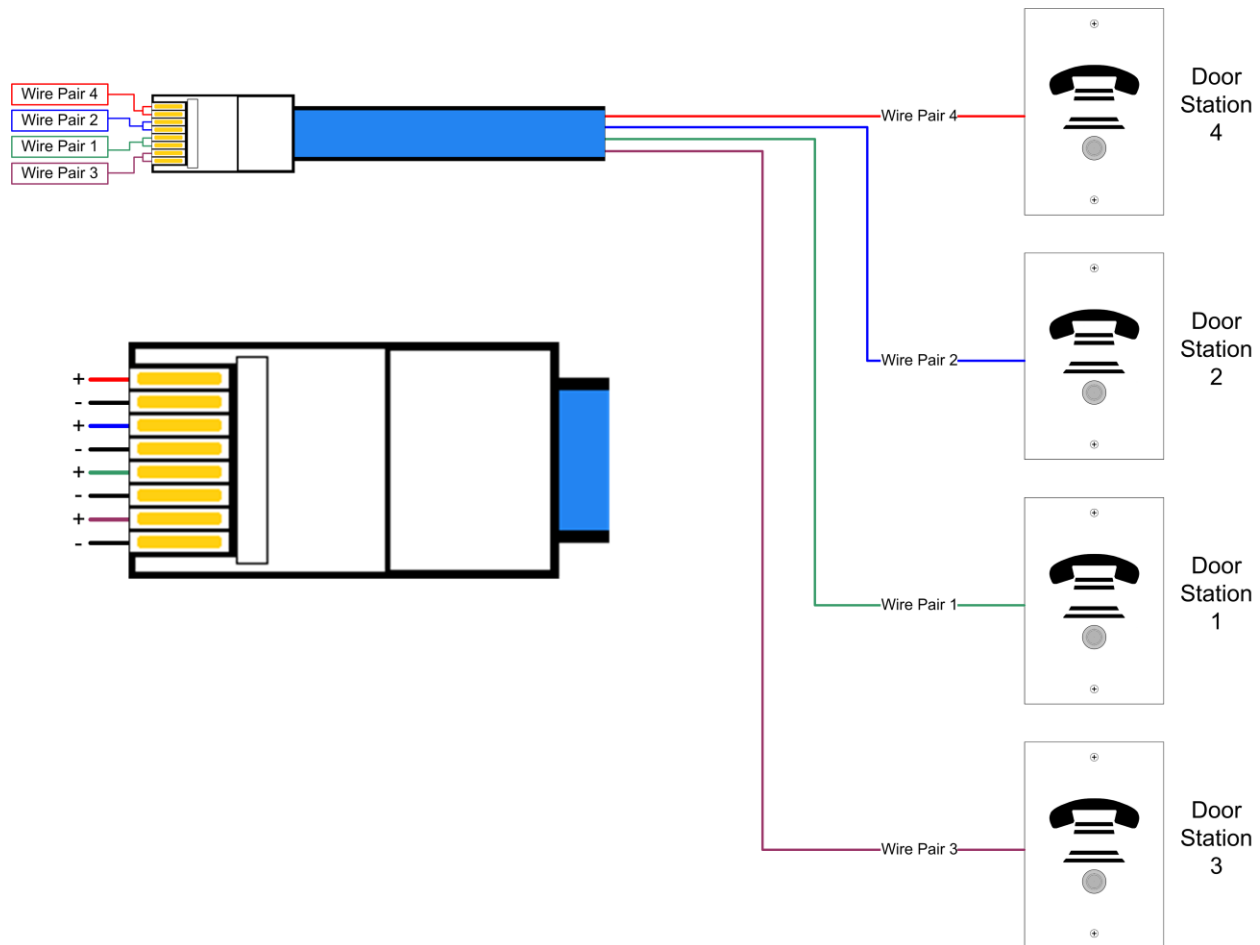

*Note: Door Station 1 has 1 ring per cycle, Door Station 2 has 2 rings per cycle, Door Station 3 has 3 rings per cycle, and Door Station 4 has 4 rings per cycle. There is a total of 5 ring cycles.

Other installation notes:

- Please use an RJ45 plug with CAT5 or CAT5e wiring when connecting wires to the DP38-C. **The RJ45 plug is needed only on the end connecting to the DP38-C.** It is possible to use an RJ11 plug, but no connection will be made if not inserted correctly.
- There is no specific color coding for the RJ45 plugs. Please keep both sides of the wires consistent.
- Only 1 pair of wires is used for each Door Station. Please do not “double up” each wire lead.
- To have an answering machine to answer a Door Station, simply set the number of rings on the answering machine to less than 5. Visitors will receive your greeting and will be able to leave a message. To avoid having the answering machine answer the Door Station, set the number of rings to greater than 5.
- If using both the DP38-SW and DP38-CI, the DP38-C is connected directly to the DP38-SW first. The DP38-SW is then connected to the DP38-CI.
- Before making any setting changes, please power down all units.

Modular Add-on Upgrades

DP38-SW: Outbound Relay Trigger

The 3rd Generation Outbound Relay Trigger allows control of electrical devices such as a gate openers or electric strikes/deadbolts through a telephone. One DP38-SW can handle 4 different electrical devices. Dip switch configuration allows for different trigger keys (7, 5, 0, *) and different release times. Most often used for electric door strikes, gates, or magnetic locks.

DP38-CI: Inbound Relay Trigger

The 3rd Generation Inbound Relay Trigger provides momentary contact closure from the push button on the door box. Dip Switches allow for different delay times. Used for door chime, lights, camera, etc.

OPERATION

When the Door Station button is pushed, the telephone will ring with a distinctive ring that is different from a regular voice call. Simply pick up the phone and it will automatically be connected to the door station. If the line is busy, a call-waiting beep will be heard. Press either the "flash" key or the hook switch and the call will be put on hold while the line is switched to the Door Station. Press the "flash" key or hook switch again to switch back to the line.

Mounting

