



SERIES 30

CENTERLINE LATCH ENTRY, ADJUSTABLE KEEPER 1/2" - 5/8" LATCH PROJECTION

**BHMA
GRADE**
3

FEATURES

- BHMA GRADE 3
- UL 1034 BURGLARY-RESISTANT
- STATIC STRENGTH 1,000 LBS
- DYNAMIC STRENGTH 33 FT-LBS.
- ENDURANCE RATING 1,000,000 CYCLES
- FULLY REVERSIBLE FOR RIGHT OR LEFT-HAND DOORS
- ADJUSTABLE KEEPER
- CONTINUOUS DUTY OPERATION (DC)
- STRIKE DEPTH 1 1/2"
- FAIL SECURE
- 5 YEAR WARRANTY
- FOUR FACEPLATE OPTIONS

DESCRIPTION

Designed with an adjustable keeper to simplify the installation. The latch cavity accommodates cylindrical locksets with a 1/2" to 5/8" throw (5/8" requires 1/8" door gap) in metal, wood or aluminum frames.



SERIES 30



DIMENSIONS

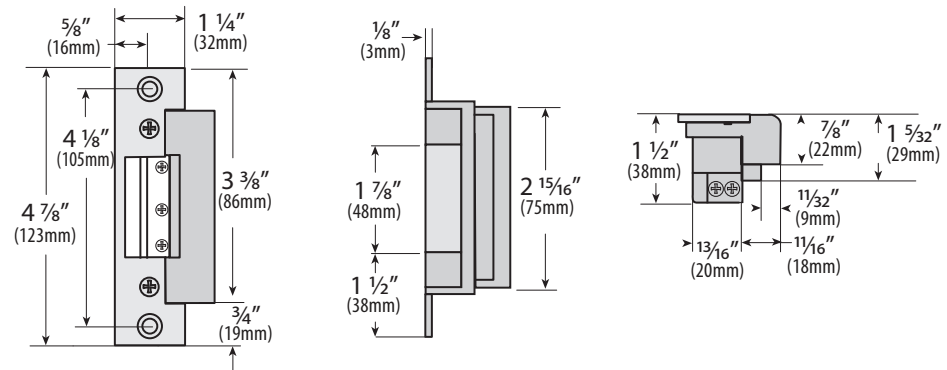

SERIES 30 ELECTRIC STRIKES

COMPATIBLE LOCK SETS	DOOR FRAME TYPE
----------------------	-----------------

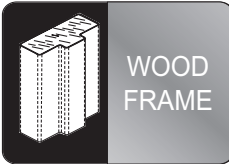
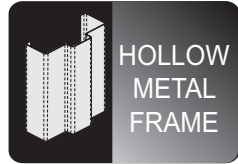
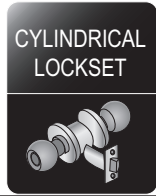

ORDERING INFORMATION

DESCRIPTION	MODEL	STRIKE COMPLETE WITH FACE PLATES			
		ANSI Square 4 7/8" x 1 1/4"	ANSI Round 4 7/8" x 1 1/4"	Hollow Metal Door 6 7/8" x 1 1/4"	Wood Door 7 15/16" x 1 1/4"
Fail Secure 8V AC/DC (.310/.360 amps) Fail Secure 16V AC/DC (.620/.730 amps)	CX-EL3001	CX-EL3011	CX-EL3021	CX-EL3031	CX-EL3041
Fail Secure 12V DC (.210 amps) Fail Secure 24V DC (.105 amps)	CX-EL3005 CX-EL3008	CX-EL3015 CX-EL3018	CX-EL3025 CX-EL3028	CX-EL3035 CX-EL3038	CX-EL3045 CX-EL3048

FACEPLATES

MODEL	DESCRIPTION
CX-ESP1	ANSI Square, 4 7/8" x 1 1/4", square corners
CX-ESP2	ANSI Round, 4 7/8" x 1 1/4", rounded corners
CX-ESP3	Hollow Metal Door, 6 7/8" x 1 1/4", rounded corners
CX-ESP4	Wood Door, 7 15/16" x 1 1/4", rounded corners

ESP1 - ANSI SQUARE ESP2 - ANSI ROUND ESP3 - HOLLOW METAL DOOR ESP4 - WOOD DOOR

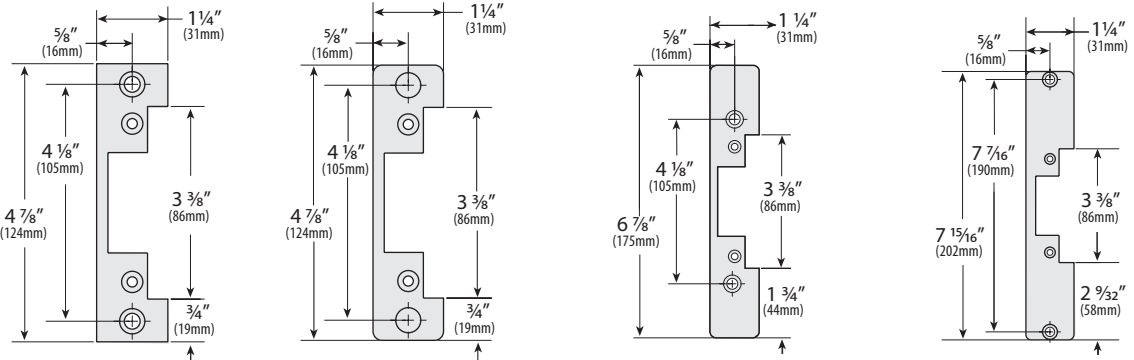

CROSS REFERENCE CHART

CAMDEN	RCI	ADAMS RITE	HES	ROFU	FOLGER ADAMS	VON DUPRIN	DYNALOCK
SERIES 30	7 SERIES	N/A	N/A	1702	N/A	N/A	N/A



5502 Timberlea Blvd. Mississauga, ON Canada L4W 2T7 • Toll Free: 1 877 226-3369 (CAMDEN9)
Tel: (905) 366-3377 • Fax: (905) 366-3378 • E-mail: info@camdencontrols.com • www.camdencontrols.com



Certified ISO 9001: 2008

LIT-SP-30

FS 541752