

CL-8, CL-8A

Microprocessor Controlled Digital Keypads



Installation Instructions

1. DESCRIPTION

1.1 System and Application

The CL-8 is a self-contained, versatile microprocessor-controlled digital keypad for indoor access control and remote control applications in security systems. Its main purpose is to limit access to restricted areas, while permitting authorized personnel to enter. Small and simple to operate, this keypad is suitable for surface mounting or flush mounting in a standard single-gang switchbox. It can function with virtually every security control panel on the market, protecting residences, factories, laboratories, hotels, offices and airports.

The CL-8 internal EEPROM can be programmed with 56 individual access codes, each assigned to an authorized individual user or to a group of users. Each code may be changed or deleted by application of a simple, straightforward programming sequence. On-site programming is carried out at the keypad, but only the **MASTER CODE** holder can access the programming menu. The programming process is aided by a green LED which shows programming information to the installer. When an access code is keyed-in and identified by the microprocessor, the CL-8 energizes a built-in 10A relay, which operates the door strike or performs any desired switching function. The relay remains energized from 1 to 98 seconds, depending on the contact closure duration programmed into the device. For special applications, the relay may be toggled by user access codes, so that keying a code once causes the relay to latch, and keying a code again unlatches the relay.

In addition to the on-board relay, an auxiliary (**AUX**) open-collector transistor output may also be tripped by certain code users for activating a control panel, operating floodlights, switching on CCTV, sounding a buzzer etc. Each of the 56 different access codes may be programmed to operate the built-in relay, the auxiliary output or both. Moreover, the auxiliary output can be programmed to function in seven different modes, one of which is the "double keystroke" (pressing keys **1** and **3** simultaneously). A different double keystroke - pressing the ***** and **#** keys simultaneously - activates a special PANIC open-collector transistor output to send out a "silent alarm" in emergency situations. A **REQUEST TO EXIT** remote input trips the relay to open the door from inside without entering a code, thereby permitting simple exit from the protected area. When the access code is being entered under duress, the authorized user can add a preset **AMBUSH** digit immediately after his access code, thus actuating the **PANIC** signal. In addition, the CL-8 is virtually impossible to defeat by unauthorized people who try to discover a correct code by trial and error: a penalty timer locks out the keypad for 30 seconds after three consecutive inputs of

erroneous codes.

Model CL-8A, with an extended operating temperature range is supplied for use in uncontrolled temperature environments. Model CL-8A EXT is designed to operate in conjunction with outdoor, vandal resistant keyboards KB-81 and KB-82, with which it forms access control systems CL-81 and CL-82, respectively (see Publication D6215). An optional tamper switch for both models is available upon request.

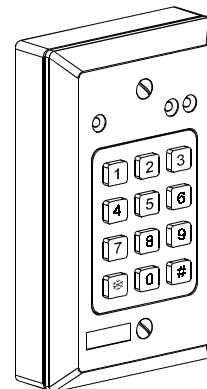

1.2 Features

- Highly versatile.
- Self contained, suitable for flush and surface mounting; supplied with a surface mounting box.
- Programmable on site by use of its own keyboard.
- Non-volatile EEPROM memory stores programmed data; unaffected by power failure.
- Up to 56 different 1-8 digit user codes can be programmed.
- More than 100 million code combinations are possible.
- User codes may be deleted individually.
- Programmable AUXILIARY open-collector output with seven powerful operating modes.
- Each user code programmable to operate the RELAY, or the AUXILIARY output, or BOTH.
- Programmable relay contact closure duration; toggle (latch/unlatch) mode may be selected if required.
- PANIC output triggered by pressing the **#** and ***** keys simultaneously.
- Three built-in LED indicators: green to indicate keypad functions; yellow and red available for optional applications.
- REQUEST TO EXIT remote input trips the relay by a remote switch or detector.
- An AMBUSH digit, if entered after the last user-code digit, sends a one-second pulse to the PANIC output.
- 9 to 16 or 22 to 26 Volts AC/DC operation.
- Tamper switch option available

2. SPECIFICATIONS

Code composition: 1 to 8 digits, any combination

Keypad type: 12 keys 3 X 4, tactile operation

Operating voltage: 9 -16 or 22 - 26 V AC/DC, selected with jumper

Current drain: 15 mA in the standby state 55 mA with relay and AUXILIARY output active

Power failure immunity: EEPROM retains all programmed information even during total power loss

Other protections: Watch-dog protection from processor hang-up

Relay contact rating: 10 A / 28 VAC or DC

Relay control: Programmable for 1 – 98 seconds contact closure duration, or for toggle (latching/unlatching) mode

Open collector outputs current sinking capability

Auxiliary output- Up to 100 mA (protected by an 18 ohm series resistor)

Panic output- Up to 100 mA (protected by an 18 ohm series resistor)

LEDs: Green indicates keypad status

Red and yellow have 1K ohm series resistors and terminals for external connections

Operating temperature

CL-8: 0°C to 65°C (32°F to 149°F)

CL-8A: -20°C to 65°C (-4°F to 149°F)

Dimensions (HxWxD): 118x72x33 mm (4-5/8 x 2-3/16 x 1-3/8 in)

Accessories: Optional tamper switch TAMP-1.

3. OPERATION

The major purpose of the CL-8 is to respond in various ways to the programmed access codes entered by authorized users, and to protect against erroneous codes entered by unauthorized people. An authorized code holder should observe the following precautions:

- Do not let anyone watch you while you key-in your code.
- Enter your access code digits one by one and then press #.
- Do not wait more than 5 seconds between successive keystrokes, or else the keypad will respond as if an incorrect code was entered, and you will have to restart.
- If you find it necessary to send a silent alarm signal without opening the door, press * and # simultaneously, so as to

trigger the PANIC circuit.

- If you are forced to enter your code under duress, press the **AMBUSH** digit immediately after entering your code. This activates the **PANIC** output but will not arouse any suspicion, since the person who is threatening you is not supposed to be familiar with the length of the digital code. When an access code is entered correctly, the keypad will respond by unlocking the door and/or tripping the auxiliary circuit, depending on the extent of control assigned to each access code. The green indicator will light up as long as the internal relay remains energized.

4. INSTALLATION

4.1 Mounting

The CL-8 is suitable for surface and flush mounting alike, but must be installed indoors. Do not install outdoors! Flush mounting is possible in any standard, single-gang electrical switchbox (see Figure 1), without the original back box. For surface mounting, use the back box supplied with the unit (Fig. 2).

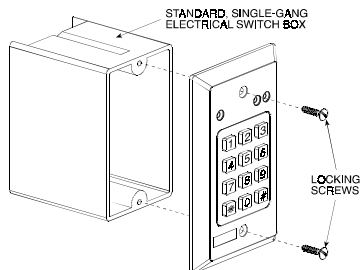

Figure 1. Flush Mounting

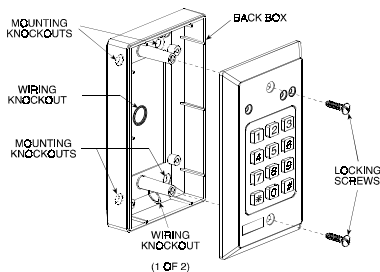

Figure 2. Surface Mounting

4.2 Wire gauges and routing

Use # 20 AWG or larger diameters for relay connections to the door strike, to the control panel or any other system used. All other connections are to be made with # 22 AWG or larger. Route the wires through the wiring knockouts on the back cover. Make no splices within the unit and avoid contact between uninsulated wires and the printed circuit board.

4.3 Connections Wiring

IMPORTANT! Before wiring be sure to set jumper JP3 in the position that corresponds with the power source you are using:
9- 6 Volts - mount the jumper across the two pins of JP3.
22-26 Volts - remove the jumper or mount it on a single pin of JP3.
 The connections to the terminal block are shown in Figure 3, with each terminal duly identified.

Proceed as follows:

- Connect the door strike leads between one of its power supply terminals and keypad terminal No. 11 (N.O.). If using a magnetic door lock, connect the magnetic lock leads between one of its power supply terminals and terminal No. 12 (N.C.).
- Connect the other terminal of the door lock power supply to terminal 10 (COM).

- Connect the panic buzzer or relay between terminal 8 (PANIC) and a +12 VDC supply. Observe polarity.
- Connect the auxiliary buzzer or relay between terminal 9 (AUX) and a +12 VDC supply. Observe polarity.

Notes:

- If the CL-8 is powered from a 12 VDC supply, the **AUX** and **PANIC** relays can be connected to terminal 7 (+).
- The **PANIC** and **AUXILIARY** outputs each include an 18 ohm resistor in series with the output. The maximum current switching capability of each output is 100 mA.

- Connect the AC or DC power supply leads to terminals 6, 7.

Caution! If the power supply provides AC, disregard polarity. If the power supply provides DC, connect the negative lead to terminal 6 and the positive lead to terminal 7.

- Connect the remote **request to exit** pushbutton or PIR contacts to terminals 5, 6. To light the red LED, connect 12 VDC between terminal 1 (+) and 2 (-). To light the yellow LED, connect 12 VDC between terminals 3 (+) and 4 (-).
- When using a tamper switch, connect the tamper N.C. terminals to a control panel normally-closed, 24-hour protection zone, or any other system used to monitor the tamper contacts using a tamper switch, connect the tamper N.C. terminals to a control panel normally-closed, 24-hour protection zone, or any other system used to monitor the tamper contacts.

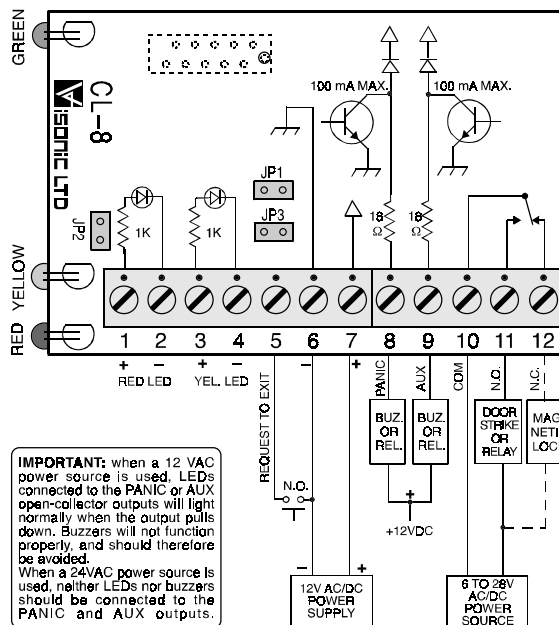

IMPORTANT: when a 12 VAC power source is used, LEDs connected to the PANIC or AUX open-collector outputs will light normally when the output pulls down. Buzzers will not function properly, and should therefore be avoided.
 When a 24VAC power source is used, neither LEDs nor buzzers should be connected to the PANIC and AUX outputs.

Figure 3. Terminal Block Wiring

4.4 Tamper Switch TAMP-1 (optional)

This option includes a terminal block and a tamper switch on a separate PC board. The tamper switch can be used in two ways:

1. To protect the CL-8 if tampering is attempted by removal of the front of the case. In this configuration, the tamper actuator remains within the case, in physical contact with the inner surface of the keypad's back box.
2. To protect the CL-8 if tampering is attempted by removing the unit from the wall or by removing the front of the case. This is accomplished by opening the tamper actuator knockout in the back box, allowing the tamper actuator to extend out of the back box and contact the wall.

Note: the tamper switch is delivered as a separate item. It is not installed at the factory. When ordering, specify TAMP-1.

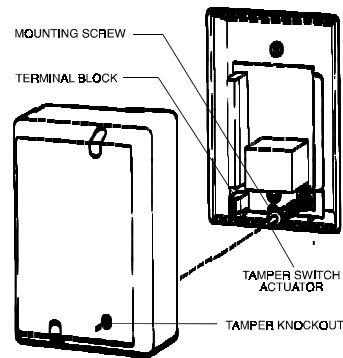

Figure 4. Tamper Switch Installation

5. PROGRAMMING PROCEDURES

5.1 Introduction

Programming the keypad is, in simple terms, providing it with a set of instructions on how to react in various contingencies. The keypad must be programmed as soon as all installation and wiring have been completed. Later on, as changes take place, partial or full reprogramming may be carried out as many times as necessary.

The first step in "telling the keypad what to do" is to access the programming menu, which is accessible only by use of the current "master code". The factory default master code is 1234, but after subsequent programming, this default code will be automatically superseded by user code No. 01, which is the real master code.

Important! Experienced programmers may refer directly to Appendices A and B at the end of this manual.

Caution: User code No. 01 must be kept secret at all times to prevent the introduction of unauthorized changes in the keypad's programming. Do not use this code for normal entry into the restricted area.

5.2 Programming Tips (Figure 5)

- A. The programming menu is selected by keying ****1234**** (1234 is the factory default master code). The Green LED will acknowledge (by flashing slowly) that the programming menu is now active.
- B. While the programming menu is active (green LED flashes slowly), you can select various programming functions by pressing a number from 1 to 5 (Table 1).

- C. Entering a function number while the green LED is flashing slowly causes the green LED to start flashing rapidly. The desired value should then be entered, followed by the "end-of data" character #.
- D. Functions 2, 3 and 5 on the menu are single-stage programming operations. If the correct data is entered, followed by #, the green LED lights steadily for 2 seconds and then resumes flashing slowly (indicates return to the menu).
- E. User Code programming (Function No. 1 on the menu) is a 4-stage operation which calls for step-by step entry of several data groups in succession (see Table 2 below). The first 3 data groups are each terminated by pressing #, which serves here as a "separating character". The last data group is also followed by keying #, which resumes its role as an "end-of-data" character.
- F. Deleting user codes (function No. 4 on the menu) is a two-stage programming operation (see Table 3). The first data group is terminated by pressing #, which serves here as a separating character. The second group is the master code followed by #, which resumes its role as an "end of data" character.

Table 1. Programming Menu

No.	Function Name	Value to enter	Description
1	Programming user codes	Any combination up to 8 digits	Each code entered is assigned to an authorized individual or to a group of people (Programming Chart - Appendix A)
2	Timing the relay	01 to 98	Sets relay contact closure duration between 1 and 98 seconds
	Latching the relay	99	Selects toggle mode (latching/unlatching)
3	Selecting AUX output mode	1 to 7	Each number entered selects a different AUXILIARY output operating mode (Table 4)
4	Deleting a single user code	user numbers, 02 to 56 + [master code]	User code corresponding to the user number entered is deleted.
	Deleting all user codes	* * # + [master code]	All user codes are deleted in a single operation, except for master code 01
5	Ambush digit	0 to 9	The programmed digit will be valid until deleted or replaced
	Delete ambush digit	*	The ambush digit is canceled

Table 2. User Code Programming Steps

Step	Enter	Description
1	1,[user no.] #	1 selects the user-code programming function; [user no.] is any number from 01 to 56.
2	[user code] #	[user code] is the individual code assigned to the user, from one to eight digits, each digit a number from 0 to 9.
3	[user code] #	[user code] repeats the previous step for verification
4	[trip code] #	1 to trip only the relay, or 2 to trip only the AUX output, or 3 to trip both the relay and the AUX output.

Table 3. User Code Deleting Steps

Step	Enter	Description
1	4, [user no.] # or: 4, * * #	4 selects the user-code deleting function; [user no.] is any number from 02 to 56. * * deletes all codes except for 01.
2	[master code] #	[master code] is entered here to make sure that the codes are being deleted by the senior user.

- G. In multi-stage programming operations (functions 1 and 4 on the menu), when the group separating character # is pressed, the green LED will light steadily for 2 seconds to acknowledge, but will then flash rapidly. Only when the "end of data" # is entered at the end of the last step - will the LED respond by lighting steadily for 2 seconds and then flashing slowly.
- H. When a programming error occurs, data is rejected, causing the green LED to go out for about three seconds and then to flash slowly. In such a case the entire programming sequence for the rejected function must be repeated.
- I. To change your mind after having selected a function on the menu, press *; the green LED will flash slowly again, indicating that the same function or a different one may be selected.
- J. To quit programming altogether and return to normal operation, press # while the green LED is flashing slowly.

5.3 Keypad preparing for operation

1. Start programming by entering * * [master code], * * (if the master code is still the factory default, you will have to enter * *,1234,* *). The green LED will start flashing slowly, indicating that the programming menu is active.
2. Enter 4,* * #,[master code]# to delete all user codes, thereby ensuring that no user codes remain in the memory as a result of factory test procedures. This is a two-stage operation, throughout which the green LED will respond as follows:
 - After entering the first [4] – rapid flashing.
 - After entering * * followed by # – steady lighting for 2 seconds and then rapid flashing again.
 - After entering the master code [1234] followed by # steady lighting for 2 seconds and then return to slow flashing.

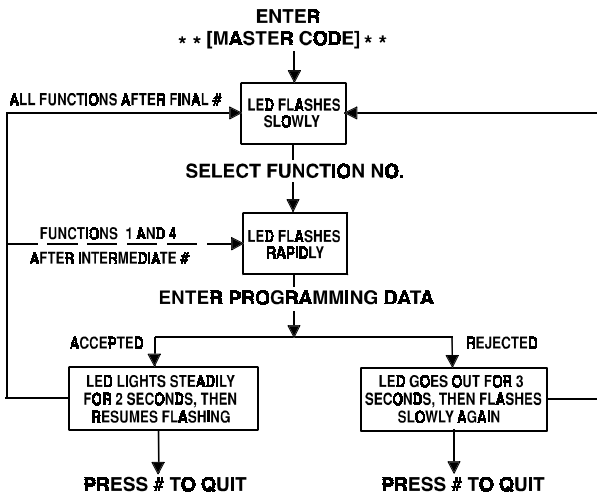

Figure 5. Programming Flow Chart

3. Set the relay timer by entering 2, [TT],# – where [TT] is the relay contact closure duration in seconds; enter 01 to 98 to obtain duration from 1 to 98 seconds, or enter 99 to cause the

relay to operate in the toggle (latch/unlatch) mode. For example, enter 05 to obtain a contact closure duration of five seconds.

4. Select the **AUXILIARY** output operating mode by entering 3, [M], # – where [M] is expressed by a number selected from the mode column in Table 4 below.

Table 4. Auxiliary Output Operating Modes

Mode	Description
1	Pulsed for 1 second by every user code authorized to operate the auxiliary output.
2	Toggled (latch/unlatch) by every user code authorized to operate the auxiliary output.
3	Operated concurrently with the relay timer, but stays enabled 5 seconds more after the relay is de-energized (operation time: TT+5 seconds). If the relay toggle mode has been selected (TT= 99), the auxiliary output will be turned on for 5 seconds each time the relay is toggled.
4	Latches by user codes authorized to trip the auxiliary output, unlatches by pressing *.
5	Turned on for ten seconds by pressing any key.
6	Oscillates at the rate of 1 Hz after 3 consecutive code errors. This condition will persist for 10 minutes, and may be reset only by entering a valid user code (resetting is possible only after the first 30 seconds, during which the keypad will be locked out as a result of the 3 code errors).
7	Turned on by pressing 1 and 3 simultaneously. Remains on while either key is pressed.

5. If you do not intend to use an **ambush digit**, it is imperative that you enter 5,* , # – the code which deletes the ambush digit – to ensure that no previously programmed digit remains in memory. If you do require an ambush digit, choose one from 0 to 9 and program it by entering - 5, [A],# – where [A] is the desired ambush digit.

IMPORTANT: Having programmed an ambush digit, you must restrict user codes to seven digits each (or less) and also avoid choosing user codes ending with that same digit. For example, if your ambush digit is 4, do not program any user codes ending with "4" (574 or 0724 or 187304 or 8234904).

6. Quit programming by pressing # while the LED is flashing slowly. The green LED will then go out.

5.4 Testing the keypad

After having prepared the keypad for operation, and before programming the various user codes, the keypad should be tested. Since no user codes have yet been programmed, the factory-default master code 1234 is the only code the CL-8 recognizes, and should operate both the relay and the auxiliary output in accordance with the latest programming (stages 3 to 6 in the previous paragraph).

- A. Enter 1234#; the **RELAY** and **AUXILIARY** outputs should operate as programmed in steps 3-4 in the previous paragraph.
- B. Test the **AMBUSH** digit (if programmed) by entering 1234[A], where [A] is the **AMBUSH** digit. This should send a 1 second pulse to the **PANIC** output.
- C. Check if the **REQUEST TO EXIT** (remote) input operates the relay.
- D. Press * and # together to verify that the **PANIC** output is activated.

5.5 Programming user codes

After verifying proper keypad operation, the user codes can be programmed. Table 5 sets an example for assigning codes to individual users.

Remember that user code No. 01 will become the new master code as soon as it is programmed, and should therefore be assigned to the person in charge of security.

It is recommended that the master code be composed of 8 digits.

Attention! If there is no ambush digit in the CL-8 memory (see Step 5 in the previous paragraph), you may program user codes freely. If you did program an ambush digit, avoid programming 8-digit user codes or codes that end with the same digit as the ambush digit.

Programming may be carried out easily by following each row in the table, after the user's name, from left to right.

Table 5. User Code Programming Chart - Sample Entries

DATE	USER'S NAME	F U N C T I O N	U S E R N O .	S E P A R A T O R	USER CODE 1 TO 8 DIGITS — HAS TO BE REPEATED FOLLOWED BY A SEPARATOR [#]	S E P A R A T O R	T R I P C O D E	E N T E R
26/6	John K.	1	01	#	43182307	#	3	#
26/6	Mark D.	1	02	#	1283406	#	1	#
26/6	Paul S.	1	03	#	018	#	2	#

- Prepare a list of user codes you want to program and record them in your **Programming Chart** (see Appendix A).
- Invoke the programming menu by entering ****,[master code],****; at this point we shall assume that the factory default of **1234** is still valid. When the programming menu is active, the green LED flashes slowly, approximately once every 2 seconds.
- Press **1** to select user code programming (function No. 1). The green LED begins to flash rapidly (approximately 5 times per second), indicating that the keypad is ready to receive data.

Remember! To prevent programming by unauthorized people, it is dangerous to continue using the default master code 1234. It is mandatory to set a new master code, which will be used for programming only and not for everyday requirements. We recommend that the master code be composed of 8 digits.

- Enter user number 01, followed by **#**. The green LED lights steadily for two seconds and then returns to rapid flashing, indicating that the step has been completed successfully.
- Enter the code assigned to this user, followed by **#**. The green LED lights steadily for 2 seconds and then returns to rapid flashing.
- Repeat the user code followed by **#**. The green LED will acknowledge as in step 5 above.
- Now select which outputs will be tripped by the new master code: enter **1** to trip only the relay, **2** to trip only the auxiliary output and **3** to trip both. Then press **#**. This time the green LED lights steadily for 2 seconds and then flashes **slowly**, indicating that the new master code and its extent of control have been programmed successfully, and that the keypad has returned to the programming menu. Now you can either program the following user code or quit programming by pressing **#** again.

Caution! From now on, code No. 01 will be recognized as the master code instead of the 1234 default, and will provide the only access to future programming.

- Continue to program all user codes as listed on your **Programming Chart**. A blank form is provided in Appendix A to this booklet, and sample entries are shown in Table 5.

Note: Do NOT enter new data if the green LED responds by going out for 3 seconds after having pressed **[#]**! If the CL-8 detects an error, the green LED turns off for three seconds and then returns to slow flashing, thus indicating that the data has not been accepted. It would be necessary to repeat the entire programming sequence for the rejected user code. If you make an error while programming, press **[*]** and you will be instantly returned to the programming menu. To quit programming, ensure that the green LED is flashing slowly, then press **[#]**. This will restore the keypad to normal operation.

5.6 Deleting user codes

- Access the programming menu by entering ****,[master code],****. With the programming menu active, the green LED will flash slowly.

- Enter **4** to select the user code deleting function. The green LED will respond by flashing rapidly, indicating that the keypad is ready to receive data.

- Enter the user number whose code you wish to delete (02 to 56), or enter **[**]** if you wish to delete all user codes, and finish off by entering **#**. The green LED will light steadily for 2 seconds and then will resume rapid flashing.

Attention: the master code (01) cannot be deleted in this manner.

- Enter the **[master code]** once more, followed by **#**. The green LED will light steadily for 2 seconds and will return to slow flashing.

- If you intend to delete another user code, return to step 2 above. If you are through deleting, restore the keypad to regular operation by pressing **#** while the green LED is flashing slowly.

5.7 Resetting the master code

If you forgot or lost the master code 01 and it becomes necessary to reprogram the keypad, it is necessary, before anything else, to reset the master code to the factory default (1234) as follows:

- Open the keypad's case, uncovering the printed circuit board.
- Install the jumper across the two pins labeled **JP2**.
- Momentarily short circuit the pins labeled **JP1** using a screwdriver or jumper wire.
- Wait ten seconds, remove the jumper from **JP2**, and immediately press **1234#**. The green LED will light steadily for two seconds and then start flashing slowly, indicating that the programming menu is active.

Important Note: The master code has temporarily reverted to 1234. Remember, however, that all other data programmed previously remains intact!

- Program a new master code (user code No. 01) immediately, and record it in a secret, safe place.

If you choose to quit programming at this stage, press **#** while the green LED is flashing slowly.

5.8 Programming changes

The keypad can be partially or entirely reprogrammed after it has been placed in regular service; the procedures are similar to those for initial programming.

- Enter ****,[master code],****. The green LED flashes slowly, indicating that the programming menu is active.
- Select any function, from 1 to 5 on the menu (Table 1).
- Function No. 1, programming user codes, entails completing four steps for each code as shown in table 2. Refer to para. 5.5.
- Having selected function No. 2 (timing or latching the relay), function No. 3 (auxiliary output mode) or function No. 5 (ambush digit) – enter the desired value and press **#** as an "end of data" character. The green LED lights continuously for 2 seconds and then flashes slowly.

Note: The codes to be entered for function No. 3 (auxiliary output mode) are specified and explained in Table 4, para 5.3

- Function No. 4 (deleting user codes) entails completing two steps as shown in Table 3. Also refer to para 5.6
- While the green LED is flashing slowly, select a new function or press **#** to restore normal operation.

5.9 Programming examples

The examples shown in this section all apply to reprogramming while the keypad functions normally. All references to "the LED" mean the green LED.

Example 1: Change the relay contact closure duration to eight seconds.

Format: **** [master code] **, 2, 08 #, #**

Description: Enter **** master code **** and wait for the LED to flash slowly. Enter **2**: the LED flashes rapidly. Enter **08#**: the LED lights for two seconds and then returns to flashing slowly. Press **#**

again to return to normal operation. Verify the timing by entering the master code or by pressing the **request to exit** switch.

Example 2: Switch the relay to the toggle (latch/unlatch) mode.

Format: ** [master code] **, 2, 99#, #

Description: Enter ** [master code] ** and wait for the LED to flash slowly. Enter **2**: the LED flashes rapidly. Enter **99#**: the LED lights for two seconds and then returns to flashing slowly. Press **#** again to return to normal operation. Verify toggle operation by entering the master code twice or by pressing **request to exit** switch twice.

Example 3: Change the **auxiliary** output to the toggle (Latch /Unlatch) mode – mode 2.

Format: ** [master code] **, 3, 2#, #

Description: Enter ** [master code] ** and wait for the LED to flash slowly. Enter **3**: the LED flashes rapidly. Enter **2#**: the LED lights for two seconds and returns to flashing slowly. Press **#** to return to normal operation. Enter the master code twice to verify that the output latches and then unlatches.

Example 4: Delete user code 15.

Format: ** [master code] **, 4, 15#, [master code] #, #

Description: Enter ** [master code] ** and wait for the LED

to flash slowly. Enter **4**: the LED flashes rapidly. Enter **15#**: the LED lights for two seconds and then flashes rapidly. Enter **[master code] #**; the LED lights for two seconds and then flashes slowly; Press **#** again to return to normal operation. Verify the deletion by attempting to use the deleted code: the keypad should not respond.

Example 5: Program the **ambush** digit to be 3.

Format: ** [master code] **, 5, 3#, #

Description: Enter ** [master code] ** and wait for the LED to flash slowly. Enter **5**: the LED flashes rapidly. Enter **3#**: the LED lights for two seconds and returns to flashing slowly. Press **#** again to return to normal operation. Verify by entering the master code with the **ambush** digit at the end; the **panic** output should be triggered for one second.

Note: To use the **ambush** digit, enter it after the last digit of any user code. If the user code is **12224** and the **ambush** digit is **3** as now programmed, then entering **122243#** will operate the **panic** output for one second.

Caution! The **ambush** digit cannot be used with an eight-digit user code. The last digit in a user code should not be identical with the **ambush** digit.

WARRANTY

Visonic Ltd. and/or its subsidiaries and its affiliates ("the Manufacturer") warrants its products hereinafter referred to as "the Product" or "Products" to be in conformance with its own plans and specifications and to be free of defects in materials and workmanship under normal use and service for a period of twelve months from the date of shipment by the Manufacturer. The Manufacturer's obligations shall be limited within the warranty period, at its option, to repair or replace the product or any part thereof. The Manufacturer shall not be responsible for dismantling and/or reinstallation charges. To exercise the warranty the product must be returned to the Manufacturer freight prepaid and insured.

This warranty does not apply in the following cases: improper installation, misuse, failure to follow installation and operating instructions, alteration, abuse, accident or tampering, and repair by anyone other than the Manufacturer.

This warranty is exclusive and expressly in lieu of all other warranties, obligations or liabilities, whether written, oral, express or implied, including any warranty of merchantability or fitness for a particular purpose, or otherwise. In no case shall the Manufacturer be liable to anyone for any consequential or incidental damages for breach of this warranty or any other warranties whatsoever, as aforesaid.

This warranty shall not be modified, varied or extended, and the Manufacturer does not authorize any person to act on its behalf in the modification, variation or extension of this warranty. This warranty shall apply to the Product only. All products, accessories or attachments of others used in conjunction with the Product, including batteries, shall be covered solely by their own warranty, if any. The Manufacturer shall not be liable for any damage or loss whatsoever, whether directly, indirectly, incidentally, consequentially or otherwise, caused by the malfunction of the Product due to products, accessories, or attachments of others, including batteries, used in conjunction with the Products.

The Manufacturer does not represent that its Product may not be compromised and/or circumvented, or that the Product will prevent any death, personal and/or bodily injury and/or damage to property resulting from burglary, robbery, fire or otherwise, or that the Product will in all cases provide adequate warning or protection. User understands that a properly installed and maintained alarm may only reduce the risk of events such as burglary, robbery, and fire without warning, but it is not insurance or a guarantee that such will not occur or that there will be no death, personal damage and/or damage to property as a result.

The Manufacturer shall have no liability for any death, personal and/or bodily injury and/or damage to property or other loss whether direct, indirect, incidental, consequential or otherwise, based on a claim that the Product failed to function.

However, if the Manufacturer is held liable, whether directly or indirectly, for any loss or damage arising under this limited warranty or otherwise, regardless of cause or origin, the Manufacturer's maximum liability shall not in any case exceed the purchase price of the Product, which shall be fixed as liquidated damages and not as a penalty, and shall be the complete and exclusive remedy against the Manufacturer.

Warning: The user should follow the installation and operation instructions and among other things test the Product and the whole system at least once a week. For various reasons, including, but not limited to, changes in environmental conditions, electric or electronic disruptions and tampering, the Product may not perform as expected. The user is advised to take all necessary precautions for his /her safety and the protection of his/her property.

6/91



VISONIC LTD. (ISRAEL): P.O.B 22020 TEL-AVIV 61220 ISRAEL. PHONE: (972-3) 645-6789. FAX: (972-3) 645-6788
VISONIC INC. (U.S.A.): 10 NORTHWOOD DRIVE, BLOOMFIELD CT. 06002-1911. PHONE: (860) 243-0833, (800) 223-0020. FAX: (860) 242-8094
VISONIC LTD. (UK): UNIT 1, STRATTON PARK, DUNTON LANE, BIGGLESWADE, BEDS. SG18 8QS. PHONE: (01767) 600857 FAX: (01767) 601098
©VISONIC LTD. 1998 CL-8 D-6205-0 NEW: DE6205- (REV. 3, 4/98)



MADE IN ISRAEL

Appendix A. User Code Programming Chart

DATE	USER NAME	FUNCTION	USER NUMBER	SEPARATING CHAR.	NEW USER CODE 1-8 DIGITS	SEPARATING CHAR.	REPEAT USER CODE FOR VERIFICATION	SEPARATING CHAR.	TRIP CODE	END OF DATA CHAR.
		1	01	#		#		#		#
		1	02	#		#		#		#
		1	03	#		#		#		#
		1	04	#		#		#		#
		1	05	#		#		#		#
		1	06	#		#		#		#
		1	07	#		#		#		#
		1	08	#		#		#		#
		1	09	#		#		#		#
		1	10	#		#		#		#
		1	11	#		#		#		#
		1	12	#		#		#		#
		1	13	#		#		#		#
		1	14	#		#		#		#
		1	15	#		#		#		#
		1	16	#		#		#		#
		1	17	#		#		#		#
		1	18	#		#		#		#
		1	19	#		#		#		#
		1	20	#		#		#		#
		1	21	#		#		#		#
		1	22	#		#		#		#
		1	23	#		#		#		#
		1	24	#		#		#		#
		1	25	#		#		#		#
		1	26	#		#		#		#
		1	27	#		#		#		#
		1	28	#		#		#		#
		1	29	#		#		#		#
		1	30	#		#		#		#
		1	31	#		#		#		#
		1	32	#		#		#		#
		1	33	#		#		#		#
		1	34	#		#		#		#
		1	35	#		#		#		#
		1	36	#		#		#		#
		1	37	#		#		#		#
		1	38	#		#		#		#
		1	39	#		#		#		#
		1	40	#		#		#		#
		1	41	#		#		#		#
		1	42	#		#		#		#
		1	43	#		#		#		#
		1	44	#		#		#		#
		1	45	#		#		#		#
		1	46	#		#		#		#
		1	47	#		#		#		#
		1	48	#		#		#		#
		1	49	#		#		#		#
		1	50	#		#		#		#
		1	51	#		#		#		#
		1	52	#		#		#		#
		1	53	#		#		#		#
		1	54	#		#		#		#
		1	55	#		#		#		#
		1	56	#		#		#		#

Appendix B. Programming Summary

Important! First access to the programming menu is gained through the factory default master code 1234. After programming, User Code No. 01 becomes the master code.

No.	Function	Keying Format	Format Explanation and Correct Response
1	Access to Programming Menu	[** MasterCode **]	<ul style="list-style-type: none"> The green LED starts to flash slowly - the programming menu is active!
2	Deleting all previous User Codes	[4] [**]# [MasterCode]#	<ul style="list-style-type: none"> After pressing [4] - rapid flashing; [**] deletes all user codes except for code No. 01; After keying [**]# - steady light for 2 seconds and then rapid flashing After Keying [Master Code]# - steady light for 2 seconds and then slow flashing.
3	Relay timing	[2] [TT]#	<ul style="list-style-type: none"> After pressing [2] - rapid flashing; [TT] = 01 to 98 seconds; 99 selects the toggle mode, in which a user code will latch or unlatch the relay; After keying [TT]# - steady light for 2 seconds and then slow flashing.
4	Selecting AUX output operating mode	[3] [M]#	<ul style="list-style-type: none"> After pressing [3] - rapid flashing; [M] = a code specifying the operating mode of the AUX output (selected from Table 4, page 13). After keying [M]# - steady light for 2 seconds and then slow flashing.
5	Defining an AMBUSH digit	[5] [A]#	<ul style="list-style-type: none"> After pressing [5] - rapid flashing; [A] = Ambush digit, 0 to 9 (see note C below) After keying [A]# - steady light for 2 seconds and then slow flashing.
6	Deleting the AMBUSH digit	[5] [*]#	<ul style="list-style-type: none"> After pressing [5] - rapid flashing; [*] = Deletes the Ambush digit After keying [*]# - steady light for 2 seconds and then slow flashing.
7	Programming user codes (prepare a list - see Appendix A)	[1] [NN]# [C]# [C]# [F]#	<ul style="list-style-type: none"> After pressing [1] - rapid flashing; [NN] = the serial number of the code user, 01 to 56 After entering [NN]# - steady light for 2 seconds and then rapid flashing. [C] = the access code allocated to this user, 1 to 8 digits After entering [C]# - steady light for 2 seconds and then rapid flashing. Repeat [C]# for verification; the LED responds as before. [F] = a code defining which outputs will be tripped by this user code 1: Authorization to trip the relay only 2: Authorization to trip the AUX output only 3: Authorization to trip both relay and the AUX output After entering [F] - steady light for 2 seconds and then slow flashing.
8	Deleting individual user codes	[4] [NN]# [Master Code]#	<ul style="list-style-type: none"> After pressing [4] - rapid flashing; [NN] = the serial number of the code user, 02 to 56 After entering [NN]# - steady light for 2 seconds and then rapid flashing After entering [Master Code]# - steady light for 2 seconds and then slow flashing.

Notes:

- Quit programming by pressing [#] when the green LED flashes slowly.
- If, while entering data, the green LED responds by going out for 3 seconds instead of lighting for 2 seconds, the data has not been accepted. Press [*] and repeat the entire stage from the beginning.
- An AMBUSH digit can not be used with 8-digit user codes, and should not be identical with the last digit in any code.
- The PANIC output is tripped by pressing [*] and [#] simultaneously.

Table 2. Auxiliary Output Operating Modes

Mode	Description
1	Pulsed for 1 second by every user code authorized to operate the auxiliary output.
2	Toggled (latch/unlatch) by every user code authorized to operate the auxiliary output.
3	Latches by user codes authorized to trip the auxiliary output, unlatches by entry of any user code.
4	Latches by user codes authorized to trip the auxiliary output, unlatches by pressing [*].
5	Turned on for ten seconds by pressing any key.
6	Oscillates at the rate of 1 Hz after 3 consecutive code errors. This condition will persist for 10 minutes, and may be reset only by entering a valid user code (resetting is possible only after the first 30 seconds, during which the keypad will be locked out a result of the 3 code errors).
7	Turned on by pressing 1 and 3 simultaneously. Remains on while either key is pressed.