

STI BIO PROTECTORS/ SNOOPER STOPPER®



STI-6514-S



STI-7505



STI-6516



PRODUCT OVERVIEW

These tough covers protect devices from abuse, accidental damage and theft of access/keypad codes. Available in clear or smoke, for applications requiring privacy. The covers can protect a wide range of devices. All covers and hinges are molded from thick polycarbonate material that is UV-stabilized.

HOW IT WORKS

STI offers a three year guarantee against breakage of polycarbonate covers in normal use. They are easy to install and are shipped complete with anchors, screws and gasket. Gasket replacement is recommended every five years.

KEY FEATURES

General Information

- Protects a wide range of equipment against abuse, accidental damage and theft.
- STI-6514, STI-6514-S & STI-6516 can be used over volume and lighting controls.
- Three year guarantee against breakage of polycarbonate in normal use.

Design

- Constructed of tough polycarbonate material, the covers can protect a wide range of devices.

Construction

- Covers are molded from thick, super tough polycarbonate material.
- All covers and hinges are molded from thick polycarbonate material that is UV-stabilized.
- 94V-2 flammability rating.

Installation

- Fast, easy installation.
- Comes complete with mounting hardware and gasket.
- Typical working properties of polycarbonate are -40° to 250°F (-40° to 121°C).

Options

- Covers come in clear or in smoke color where privacy is required (STI-6516 clear only).



For more information, call 1-800-888-4784 (4STI) or visit www.sti-usa.com



**Safety Technology
International, Inc.**

STI Bio Protectors/Snooper Stopper®

Dimensions and Technical Information

MODELS AVAILABLE

- TI-6514** Bio protector - identification reader cover - clear
- STI-6514-S** Bio protector - identification reader cover - smoke color
- STI-6516** Mini Bopper Stopper with spring loaded hinge - clear
- STI-7504** Snooper Stopper – clear
- STI-7505** Snooper Stopper – smoke
- BIO-7504*** Bio protector - identification reader cover - clear
- BIO-7505*** Bio protector - identification reader cover - smoke color

* Includes 1" thick gasket

APPROVALS & WARRANTY

TESTING

- Tested and approved or listed by:
- Underwriter Laboratories No. S7255
 - Canadian Underwriter Laboratories No. S7255
 - California State Fire Marshal approval not required
 - ADA Compliant (STI-6516 only)

WARRANTY

Three year guarantee against breakage of polycarbonate in normal use.

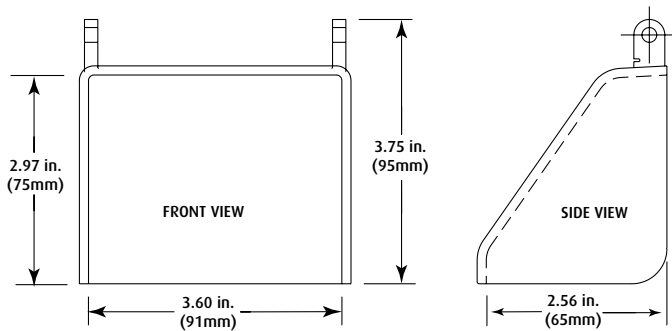

STI-6514

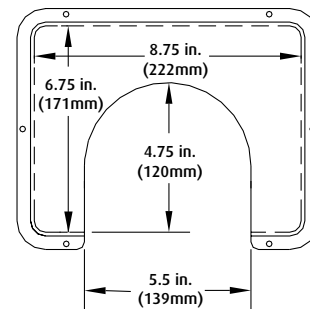

FRONT VIEW

BIO-7504/7505
STI-7504/7505

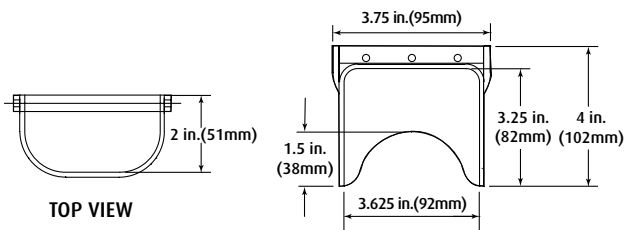

TOP VIEW

FRONT VIEW

STI-6516

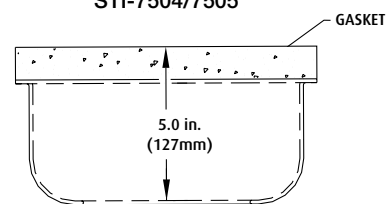

TOP VIEW

BIO-7504/7505

STI-7504/7505

4 inches deep



Safety Technology International, Inc.

2306 Airport Road
Waterford, Michigan
48327, USA

Tel: 248-673-9898
Fax: 248-673-1246
Toll-free: 800-888-4784
info@sti-usa.com
www.sti-usa.com

Unit 49G Pipers Road
Park Farm Industrial Estate
Redditch, Worcestershire
B98 0HU England

Tel: 44 (0) 1527 520 999
Fax: 44 (0) 1527 501 999
www.sti-europe.com