

G U I D E

Tower Camera



Please read this manual thoroughly before use, and keep it handy for future reference. Design and specifications are subject to change without notice.

WARNING

TO REDUCE THE RISK OF FIRE OR ELECTRIC SHOCK, DO NOT EXPOSE THIS PRODUCT TO RAIN OR MOISTURE. DO NOT INSERT ANY METALLIC OBJECTS THROUGH THE VENTILATION GRILLS OR OTHER OPENINGS ON THE EQUIPMENT.

CAUTION

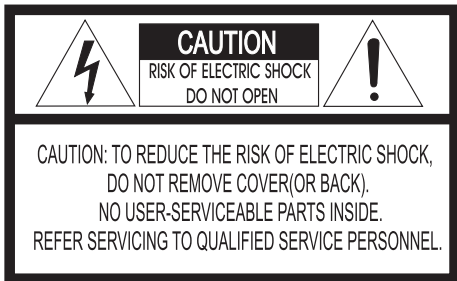

EXPLANATION OF GRAPHICAL SYMBOLS



The lightning flash with arrowhead symbol, within an equilateral triangle, is intended to alert the user to the presence of uninsulated "dangerous voltage" within the product's enclosure that may be of sufficient magnitude to constitute a risk of electric shock to persons.



The exclamation point within an equilateral triangle is intended to alert the user to the presence of important operating and maintenance (servicing) instructions in the literature accompanying the product.

PRECAUTIONS

Safety -----

Should any liquid or solid object fall into the cabinet, unplug the unit and have it checked by the qualified personnel before operating it any further.

Unplug the unit from the wall outlet if it is not going to be used for several days or more. To disconnect the cord, pull it out by the plug. Never pull the cord itself.

Allow adequate air circulation to prevent internal heat build-up. Do not place the unit on surfaces (rugs, blankets, etc.) or near materials (curtains, draperies) that may block the ventilation holes.

Installation -----

Do not install the unit in an extremely hot or humid place or in a place subject to excessive dust, mechanical vibration.

Cleaning -----

Clean the unit with a slightly damp soft cloth. Use a mild household detergent. Never use strong solvents such as thinner or benzene as they might damage the finish of the unit.

Retain the original carton and packing materials for safe transport of this unit in the future.

FCC COMPLIANCE STATEMENT

This device complies with Part 15 of the FCC Rules. Operation is subject to the following two conditions: (1) this device may not cause harmful interference, and (2) this device must accept any interference received, including interference that may cause undesired operation.

FCC INFORMATION : This equipment has been tested and found to comply with the limits for a Class A digital device, pursuant to Part 15 of the FCC Rules. These limits are designed to provide reasonable protection against harmful interference when the equipment is operated in a commercial environment. This equipment generates, uses, and can radiate radio frequency energy and, if not installed and used in accordance with the instruction manual, may cause harmful interference to radio communications. Operation of this equipment in a residential area is likely to cause harmful interference in which case the user will be required to correct the interference at his own expense.

CAUTION : Changes or modifications not expressly approved by the party responsible for compliance could void the user's authority to operate the equipment.

This Class A digital apparatus complies with Canadian ICES-003.

Cet appareil numérique de la classe A est conforme à la norme NMB-003 du Canada.

CE COMPLIANCE STATEMENT

WARNING

This is a Class A product. In a domestic environment this product may cause radio interference in which case the user may be required to take adequate measures.

IMPORTANT SAFETY INSTRUCTIONS

1. Read these instructions.
2. Keep these instructions.
3. Heed all warnings.
4. Follow all instructions.
5. Do not use this apparatus near water.
6. Clean only with dry cloth.
7. Do not block any ventilation openings. Install in accordance with the manufacturer's instructions.
8. Do not install near any heat sources such as radiators, heat registers, stoves, or other apparatus (including amplifiers) that produce heat.
9. Do not defeat the safety purpose of the polarized or grounding-type plug. A polarized plug has two blades with one wider than the other. A grounding type plug has two blades and a third grounding prong. The wide blade or the third prong are provided for your safety. If the provided plug does not fit into your outlet, consult an electrician for replacement of the obsolete outlet.
10. Protect the power cord from being walked on or pinched particularly at plugs, convenience receptacles, and the point where they exit from the apparatus.
11. Only use attachments/accessories specified by the manufacturer.
12. Use only with the cart, stand, tripod, bracket, or table specified by the manufacturer, or sold with the apparatus. When a cart is used, use caution when moving the cart/apparatus combination to avoid injury from tip-over.
13. Unplug this apparatus during lightning storms or when unused for long periods of time.
14. Refer all servicing to qualified service personnel. Servicing is required when the apparatus has been damaged in any way, such as power-supply cord or plug is damaged, liquid has been spilled or objects have fallen into the apparatus, the apparatus has been exposed to rain or moisture, does not operate normally, or has been dropped.
15. **CAUTION - THESE SERVICING INSTRUCTIONS ARE FOR USE BY QUALIFIED SERVICE PERSONNEL ONLY. TO REDUCE THE RISK OF ELECTRIC SHOCK DO NOT PERFORM ANY SERVICING OTHER THAN THAT CONTAINED IN THE OPERATING INSTRUCTIONS UNLESS YOU ARE QUALIFIED TO DO SO.**
16. Use satisfy clause 2.5 of IEC60950-1/UL60950-1 or Certified/Listed Class 2 power source only.



1. Features

- Blends into the environment for transaction application
- User adjustable height 19.3" ~ 26.3" (Height control range : 7")
- 1" Height Interval to adjust the height
- Adjustable Lens Tilting Angle $-10^{\circ} \sim +10^{\circ}$
- Adjustable Base Panning Angle $-45^{\circ} \sim +45^{\circ}$
- High resolution and high performance 1/3" CCD Technology
- Excellent picture quality
- 700 lines(Color) of resolution
- 0.1 lux (Color), 0.04 lux(B/W) @ F1.2 50IRE Sensitivity
- Auto electronic shutter [1/60(1/50) ~ 1/100,000]
- Auto white balance
- AGC (Auto Gain Control)
- 2D DNR
- 3.6mm Fixed Lens
- Operates in DC 12V~15V +/- 10%

2. Camera Connections

1-TYPE

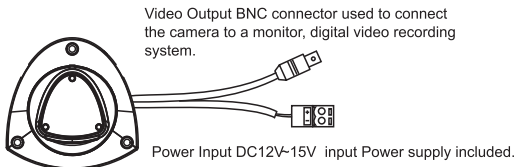

[TOP VIEW]

2-TYPE

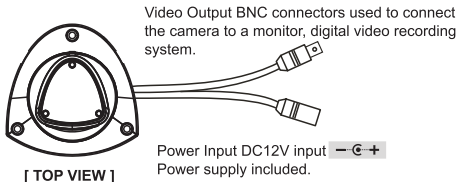

[TOP VIEW]

3. Installation

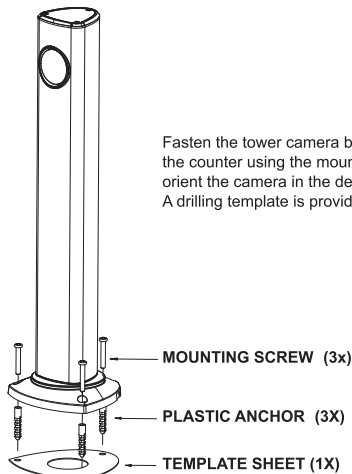

[Installation 1]

* OPTION

Attach the tower camera to the surface using the solid base with the double-sided adhesive tape.

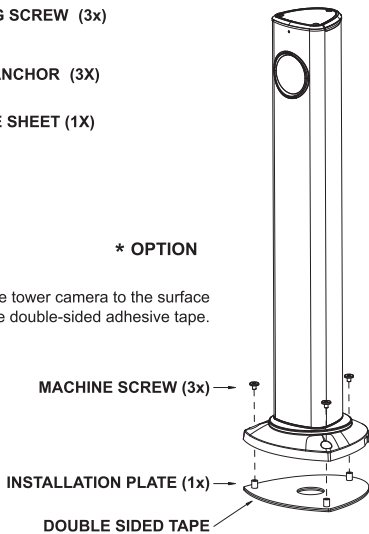

[Installation 2]

4. How to use

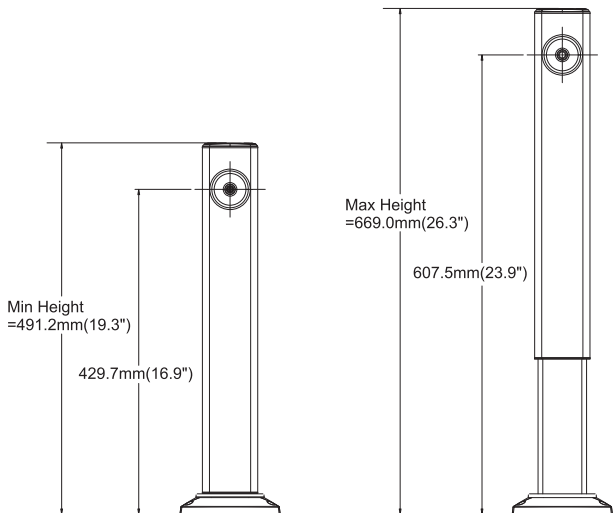

[FRONT VIEW]

THE RANGE OF PANNING ANGLE : $-45^{\circ} \sim +45^{\circ}$

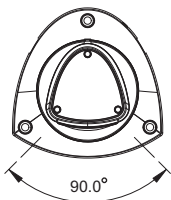

[TOP VIEW]

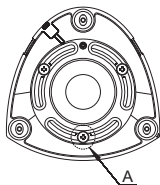

[BOTTOM VIEW]

To adjust the panning position of the lower camera, uncrew the "A" point.

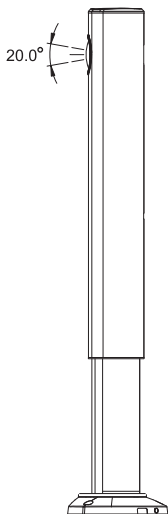

[SIDE VIEW]

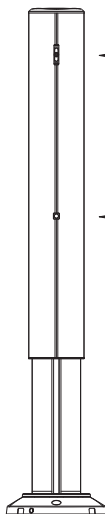

[BACK VIEW]

Two knockouts for cable entry.

← THE RANGE OF TILTING ANGLE : $-10^{\circ}\sim+10^{\circ}$

- Adjust tilt to desired position using the lever. A single threaded lever is used to adjust both elevation and tilt angle by moving it from one position to the other.

← THE LOCK POINT FOR POSITIONING OF THE TOWER CAMERA
(THE MOVABLE DISTANCE : 7" INCH)
(THE DISTANCE OF HOLES : 1" INCH APART)

- Pull out the spring loaded lever to adjust the camera's height then push the lever to lock the camera.
- The lever may be removed for security by unscrewing it.

5. Specifications

MODEL		NTSC	PAL
Power	Power source	DC12V \pm 10%	
	Power consumption	130mA(1.6 Watts)	
General	Image sensor	1/3" CCD	
	Total pixels	1020(H) x 508(V)	1020(H) x 596(V)
	Sync. system	Internal	
	Scanning frequency	15.734KHz(H), 59.94Hz(V)	15.625KHz(H),50Hz(V)
	Electronic shutter	1/60 ~ 1/100,000sec.	1/50 ~ 1/100,000sec.
	Resolution	700 TV Lines (Color)	
	Min. illumination	0.1 Lux (Color), 0.04 Lux(B/W) @ F1.2, 50 IRE	
	Video output	1.0 Vp-p (75 ohm, composite)	
	S/N ratio	more than 50dB (AGC off)	
	FUNCTION	Auto Exposure	ON
White Balance		AUTO (ATW)	
Day& Night		AUTO	
2D-DNR		ON	
AGC		AUTO	
Connector & etc.	Power input	Terminal Block / DC Jack	
	Video output	BNC connector	
	Lens mount	Fixed mount	
	Lens	f=3.6mm Fixed Lens	
	Operating temperature	14°F~122°F (-10°C~+50°C)	
	Operating humidity	0 ~ 96% (non-condensing)	
	External dimension	2.9"(W) X 19.3"~26.3"(H) X2.9"(D), Base 5.2" X 5.2"	
Weight	1.1Kg		

● Power Input Connector Option

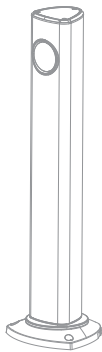

G U I D E

Tower Camera
