



PD4ULCB - UL Listed Sub-Assembly Power Distribution Module

Overview:

The PD4ULCB is a UL Listed Sub-Assembly power distribution module, designed to convert a single DC input into four (4) PTC protected Class 2 Rated power-limited outputs.

Agency Listings:

- UL Listed Sub-Assembly for Access Control System Units (UL 294) and for Power Supplies for Fire Protective Signaling Systems (UL 1481).
- cUL Listed: General Signaling Equipment Evaluated to CSA Standard C22.2 No.205-M1983



Specifications:

Outputs:

- Four (4) individually PTC protected outputs @ 2 amp per output max. current (total output current should not exceed max. current rating of power supply employed).

PTC Ratings:

- PTCs are rated @ 2A/250V.

Visual Indicators:

- Power on green LED indicator.

Board Dimensions (W x L x H approximate):

3.25" x 5.25" x 1" (82.55mm x 133.35mm x 25.4mm).

Installation Instructions:

Wiring methods shall be in accordance with the National Electrical Code/NFPA 70/NFPA 72/ANSI, and with all local codes and authorities having jurisdiction. Product is intended for indoor use only and should be installed by qualified personnel.

1. Refer to Sub Assembly Installation Instruction for mounting Rev. MS042511.
2. Connect the desired power supply output to the terminals marked [INPUT] (Fig. 1).
Note: Left terminal is NEG. (-) and right terminal is POS. (+) (Fig. 1).
3. Measure output voltage before connecting devices. This helps avoiding potential damage.
4. Connect devices to be powered to the terminal pairs 1 to 4, marked [1P - 1N] through [4P - 4N]. All terminals with common suffix P "1P, 2P..." are same polarity.

Note: This product is a UL Listed Sub-Assembly for use with Altronix UL Listed power supplies as indicated in the installation manuals for the power supply.

Note: DC outputs are power-limited.

Caution: Do not expose to rain or moisture.

(#P) Positive DC outputs

(#N) Negative DC outputs

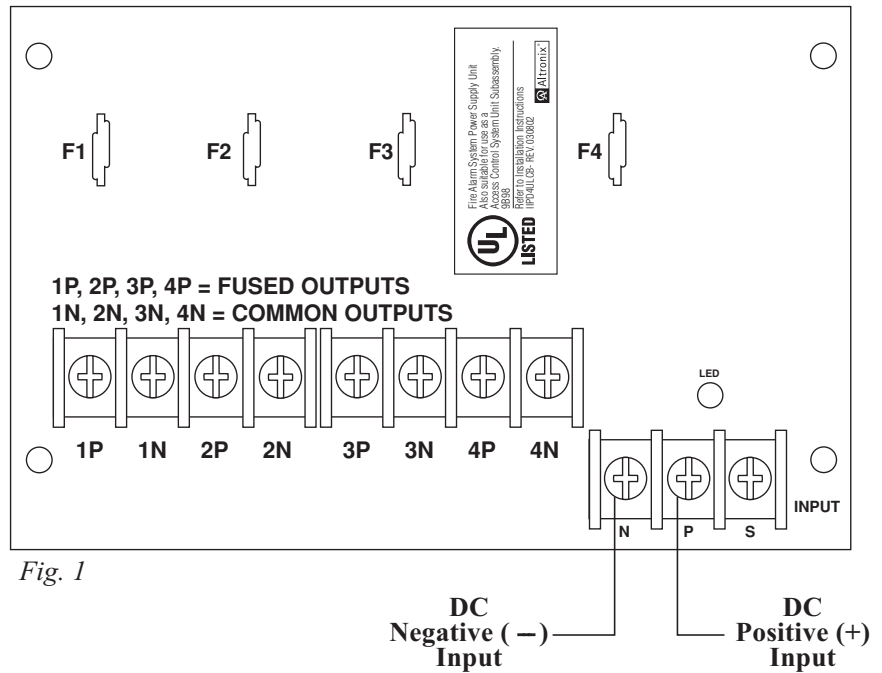

Fig. 1

Altronix is not responsible for any typographical errors.

140 58th Street, Brooklyn, New York 11220 USA, 718-567-8181, fax: 718-567-9056
website: www.altronix.com, e-mail: info@altronix.com, Lifetime Warranty, Made in U.S.A.
IIPD4ULCB - Rev. 051311

B19N

