

MAXIMAL™

Rack Mount Series

Installation Guide

Models Include:

Maximal1RHD

- 12VDC @ 4 amp or 24VDC @ 3 amp.
- Eight (8) PTC Protected Outputs.

Maximal3RHD

- 12VDC or 24VDC @ 6 amp.
- Eight (8) PTC Protected Outputs.

Maximal33RD

- 12VDC and/or 24VDC @ 12 amp.
- Sixteen (16) PTC Protected Outputs.

Maximal1RD

- 12VDC @ 4 amp or 24VDC @ 3 amp.
- Sixteen (16) PTC Protected Outputs.

Maximal3RD

- 12VDC or 24VDC @ 6 amp.
- Sixteen (16) PTC Protected Outputs.



Table of Contents:

| | |
|---|-----|
| MaximalD Rack Mount Series Overview | 3 |
| MaximalD Rack Mount Series Configuration Chart..... | 3 |
| MaximalD Rack Mount Series Specifications | 3 |
| Installation Instructions | 3-4 |
| Maintenance..... | 5 |
| Fire Alarm Interface Switch Settings | 5 |
| Output Voltage and Stand-by Specification Charts | 5 |
| LED Diagnostics..... | 5 |
| Power Supply Board Output Voltage Settings | 6 |
| Fire Alarm Interface, Output Selection and Input Type | 6 |
| Power Supply Board Drawings | 8 |
| FACP Hook-up Diagrams | 9 |
| Mounting Bracket Diagrams | 10 |
| Rack Mechanical Drawing and Dimensions | 11 |

Overview:

These units distribute and switch power to access control systems and accessories. They convert a 115VAC 50/60Hz input into eight (8) or sixteen (16) independently controlled 12VDC and/or 24VDC PTC protected outputs. Outputs are activated by an normally open (NO) or normally closed (NC) dry trigger input from an Access Control System, Card Reader, Keypad, Push Button, PIR, etc. Units will route power to a variety of access control hardware devices including: Mag Locks, Electric Strikes, Magnetic Door Holders, etc. Outputs will operate in both Fail-Safe and/or Fail-Secure modes. The FACP Interface enables Emergency Egress, Alarm Monitoring, or may be used to trigger other auxiliary devices. The fire alarm disconnect feature is individually selectable for any or all of the outputs (see chart below).

Maximal Rack Mount Series Configuration Chart:

| Altronix Model Number | Power Supply 1 (8 outputs) | Power Supply 2 (8 outputs) | Total Output Current | Fuse Protected Outputs | Maximum Current Per ACM8CBR-M Output | 115VAC 50/60Hz Input (current draw) | Power Supply Board Input Fuse Rating |
|------------------------------|---------------------------------------|---------------------------------------|-----------------------------|-------------------------------|---|--|---|
| Maximal1RHD | 12VDC @ 4 amp | N/A | 4 amp | 8 | 2.0 amp | 1.9 amp | 5A/250V |
| | 24VDC @ 3 amp | N/A | 3 amp | | | | |
| Maximal1RD | 12VDC @ 4 amp | N/A | 4 amp | 16 | 2.0 amp | 1.9 amp | 5A/250V |
| | 24VDC @ 3 amp | N/A | 3 amp | | | | |
| Maximal3RHD | 12VDC @ 6 amp | N/A | 6 amp | 8 | 2.0 amp | 1.9 amp | 3.5A/250V |
| | 24VDC @ 6 amp | N/A | | | | | |
| Maximal3RD | 12VDC @ 6 amp | N/A | 6 amp | 16 | 2.0 amp | 1.9 amp | 3.5A/250Vc |
| Maximal33RD | 12VDC @ 6 amp | 12VDC @ 6 amp | 12 amp | 16 | 2.0 amp | 3.8 amp | 3.5A/250Vc |
| | 24VDC @ 6 amp | 24VDC @ 6 amp | | | | | |
| | 12VDC @ 6 amp | 24VDC @ 6 amp | | | | | |

Specifications:

Inputs:

- Normally closed [NC] or normally open [NO] dry contact inputs (switch selectable).

Outputs:

- Individually selectable Mag Lock/Strike (Fail-Safe, Fail-Secure) solid state PTC protected power outputs.
- Thermal and short circuit protection with auto reset.

Fire Alarm Interface:

- Fire Alarm disconnect (latching with reset or non-latching) is individually selectable for any or all of the outputs.
- Remote reset capability for latching Fire Alarm Interface mode.
- Fire Alarm disconnect input options:
 - a) Normally open [NO] or normally closed [NC] dry contact input.
 - b) Polarity reversal input from FACP signaling circuit.

Visual Indicators:

- Individual Output Status LEDs located on the front panel.

Battery Backup:

- Built-in charger for sealed lead acid or gel type batteries (A separate enclosure is required for batteries).
- Maximum charge current 0.7 amp.
- Automatic switch over to stand-by battery when AC fails.
- Zero voltage drop when unit switches over to battery backup (AC failure condition).

Supervision:

- AC fail supervision (form "C" contact).
- Low battery supervision (form "C" contact).

Additional Features:

- Removable terminal blocks with locking screw flange.
- 3-wire line cord.
- Illuminated master power disconnect circuit breaker with manual reset.

Rack Dimensions:

3.25"H x 19.125"W x 8.5"D

Installation Instructions:

Important: Adjust output voltages, and Fire Alarm Interface configuration before installing unit in the rack.

1. Separate bottom and top of rack mount chassis by removing six (6) screws (*Rack Mechanical Drawing & Dimensions, pg. 11*).
2. **Set output voltage:**

Select desired DC output voltage by setting SW1 on the power supply board(s) (*Fig. 1a, pg. 6*) to the appropriate position (*Output Voltage and Stand-by Specification Charts, pg. 5*).

For Maximal33RD each set of eight (8) outputs can be set for 12VDC or 24VDC (example: eight (8) outputs @ 12VDC and eight (8) outputs @ 24VDC).
3. **Input trigger programming options:**

The unit can be programmed to operate with either a normally open or normally closed input from access control devices by setting switches SW3 on either the ACM8CBR-S or ACM16CBR-S board to the appropriate position (*Fig. 2b, pg. 7*); OPEN for a normally closed [NC] trigger input or CLOSED for a normally open [NO] input.
4. **Output programming options:**
 - a. The outputs can be programmed to be either all Fail-Safe (i.e. mag locks), all Fail-Secure (i.e. electric strikes) or any combination of each by setting the corresponding OUTPUT SELECT dip switches (1-8) on the ACM8R-S board to the appropriate position; ON for Fail-Safe outputs or OFF for Fail-Secure outputs (*Fig. 2a, pg. 7*).
 - Note:** the output configuration will follow the input trigger option
 - b. To enable the FACP Disconnect for an output the corresponding FIRE ALARM INTERFACE switch must be in the ON position. To disable the FACP Disconnect the FIRE ALARM INTERFACE dip switches (1-8) on the ACM8CBR-S/ACM16CBR-S board must be in the OFF position (*Fig. 2a, pg. 7*).
5. **Fire Alarm Interface hookup options:**

A normally closed [NC], normally open [NO] input or polarity reversal from an FACP signaling circuit will trigger the selected outputs (*Figs. 6-11, pg. 9*). To program the Fire Alarm Interface set dip switches SW1 and SW2 on the ACM8CBR-M board to the appropriate positions (*Figs. 3a & 3b, pg. 7*) (*Fire Alarm Interface Switch Settings pg. 5*).
6. **Battery Connections:**

For access control applications batteries are optional. If batteries are not used a loss of AC will result in the loss of output voltage. When batteries are used they must be lead acid or gel type. Connect one (1) battery to the terminals marked [- BAT +] for 12VDC operation. Use two (2) 12VDC batteries wired in series for 24VDC operation (*Fig. 4b/5b, pg. 8*). The rack mount enclosure will not accommodate batteries. A separate battery enclosure is required.

Note: When using the Maximal33RD with battery backup two (2) separate batteries or sets of batteries must be used.
7. **Battery and AC Supervision outputs:**

Connect the appropriate notification signaling device to the terminals marked AC Fail and Battery Fail on the power supply board(s) (*Fig. 4a/5a, pg. 8*). Use 22AWG to 18AWG for AC Fail and Low/No Battery reporting.
8. Reassemble the bottom and top of rack mount chassis by fastening the six (6) screws. (*Rack Mechanical Drawing & Dimensions pg. 11*).
9. Attach mounting brackets to rack mount Maximal for desired rack or wall installation (*Fig. 12-14, pg. 10*).
10. Mount in desired rack location. Do not obstruct side air vents.
11. Set the power disconnect circuit breaker to the OFF position (*Fig. 15a, pg. 11*).
12. Plug power cord into grounded 50/60Hz receptacle (*Fig. 15b, pg. 11*).
13. Set the power disconnect circuit breaker to the ON position (*Fig. 15a, pg. 11*).
14. Measure the output voltage before connecting devices. This helps avoid potential damage.
15. Set the power disconnect circuit breaker to the OFF position (*Fig. 15a, pg. 11*).
16. **Input trigger connections:**

Connect the Normally Open or Normally Closed input triggers from the access control devices to the removable terminals marked [IN1 and GND] through [IN8 and GND] for Maximal1RHD and Maximal3RHD. For Maximal1RD, Maximal3RD and Maximal33RD connect devices to the second set of terminals marked. For Make sure the devices match settings of SW3 in step 3 (*Rack Mechanical Drawing & Dimensions pg. 11*).
17. **Output connections:**

Connect the devices to be powered to the removable terminals marked [- OUT1 + to - OUT8 +] for Maximal1RHD and Maximal3RHD. For Maximal1RD, Maximal3RD and Maximal33RD connect devices to the second set of terminals marked [- OUT1 + to - OUT8 +] (*Fig. 15c, pg. 11*).
18. **Fire Alarm Interface connection options:**
 - a. Connect the FACP trigger input to the removable terminals marked FACP1 and FACP2. When using the polarity reversal from an FACP signaling circuit, connect the negative [-] to the terminal marked FACP1 and the positive to the terminal marked FACP2 (polarity is in alarm condition) (*Rack Mechanical Drawing & Dimensions pg. 12*).

- b. For a latching fire alarm interface connect a normally [NO] reset switch to the removable terminals marked [REST] and [GND] (Figs. 6-11, pg. 9).
19. Set the power disconnect circuit breaker to the ON position (Fig. 15a, pg. 11).

Maintenance:

Unit should be tested at least once a year for the proper operation as follows:

Output Voltage Test: Under normal load conditions, the DC output voltage should be checked for proper voltage level (Output Voltage and Stand-by Specification Charts, pg. 5).

Battery Test: Under normal load conditions check that the battery is fully charged, check specified voltage at the battery terminals and at the board terminals marked [- BAT +] to insure that there is no break in the battery connection wires.

Fire Alarm Interface Switch Settings:

| Switch Position | | FACP Input |
|-----------------|--------|--|
| SW1 | SW2 | |
| Open | Open | FACP Signal Circuit (Polarity Reversal). |
| Closed | Closed | Normally Closed [NC] Trigger Input. |
| Closed | Open | Normally Open [NO] Trigger Input. |

Output Voltage and Stand-by Specification Charts:

| Altronix Model | Power Supply Board | Battery | 20 Min. of Backup | 4 Hr. of Backup | 24 Hr. of Backup |
|--|---|-------------|-------------------|-----------------|------------------|
| Maximal1RHD Maximal1RD | OLS120 (Refer to Fig. 1a, pg. 4 for Switch [SW1] location and position) | 12VDC/40AH* | N/A | 3.5 amp | 0.5 amp |
| | | 24VDC/40AH* | N/A | 2.7 amp | 0.7 amp |
| Maximal3RHD Maximal3RD Maximal33RD | AL600ULXB (Refer to Fig. 1a, pg. 4 for Switch [SW1] location and position) | 12VDC/40AH* | N/A | 5.5 amp | 5.5 amp |
| | | 24VDC/40AH* | N/A | 5.5 amp | 0.7 amp |

LED Diagnostics:

Power Supply Board

| LED | | Power Supply Status |
|----------|------------|--|
| Red (DC) | Green (AC) | |
| ON | ON | Normal operating condition. |
| ON | OFF | Loss of AC, Stand-by battery supplying power. |
| OFF | ON | No DC output. Short circuit or thermal overload condition. |
| OFF | OFF | No DC output. Loss of AC. Discharged battery. |

Output LEDs on Front Panel

| | |
|----------|----------------------|
| ON | Output is triggered. |
| Blinking | FACP disconnect. |

WARNING: To reduce the risk of fire or electric shock, do not expose the unit to rain or moisture. This installation should be made by qualified service personnel and should conform to all local codes and in accordance with the National Electrical Code.



The lightning flash with arrow head symbol within an equilateral triangle is intended to alert the user to the presence of an insulated “DANGEROUS VOLTAGE” within the products enclosure that may be of sufficient magnitude to constitute an electric shock.



The exclamation point within an equilateral triangle is intended to alert the user to the presence of important operating and maintenance (servicing) instructions in the literature accompanying the appliance.



CAUTION
RISK OF ELECTRIC SHOCK
DO NOT OPEN



CAUTION: To reduce the risk of electric shock do not open enclosure. There are no user serviceable parts inside. Refer servicing to qualified service personnel.

Power Supply Board Output Voltage Settings:

Fig. 1 Maximal1RHD, Maximal1RD
Power Supply Board

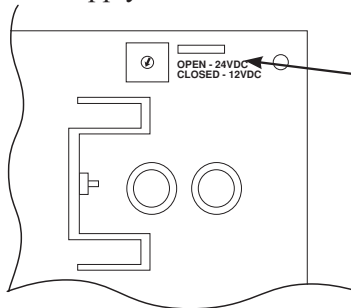
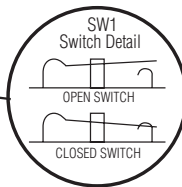
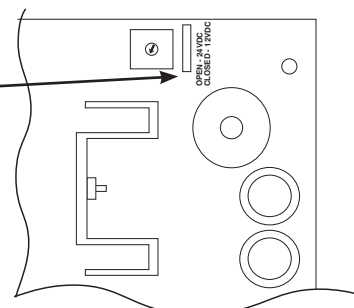

Fig. 1a



Maximal3RHD, Maximal3RD,
Maximal33RD Power Supply Boards



Fire Alarm Interface, Output Selection and Input Type:

Fig. 2

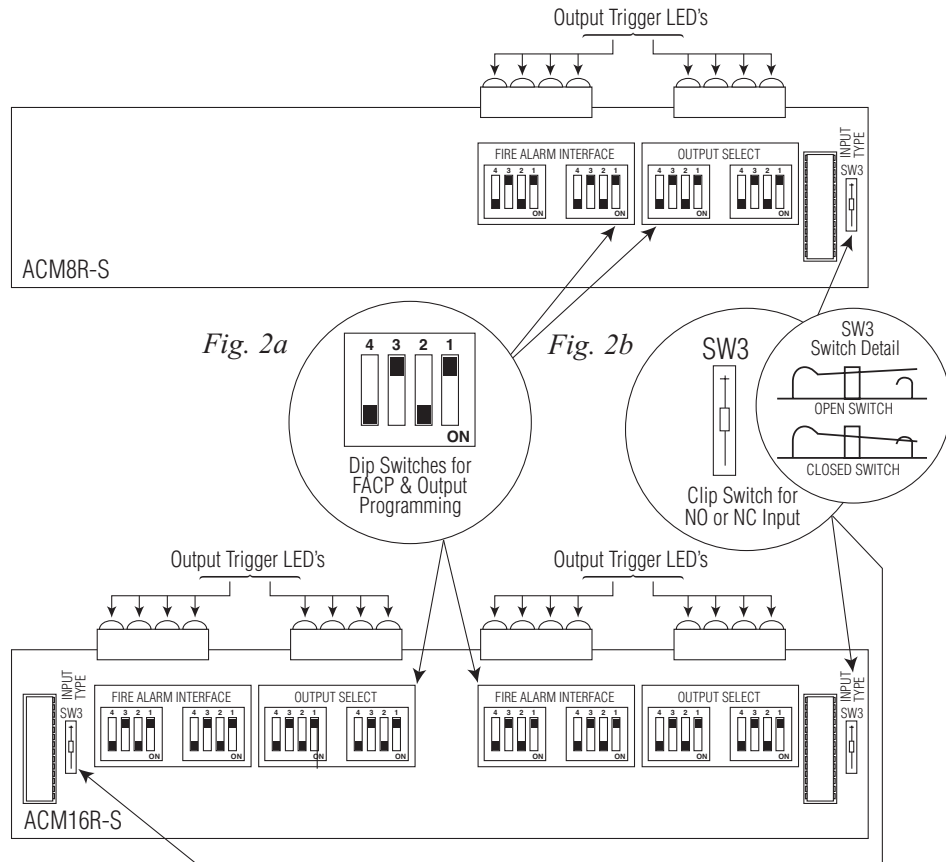
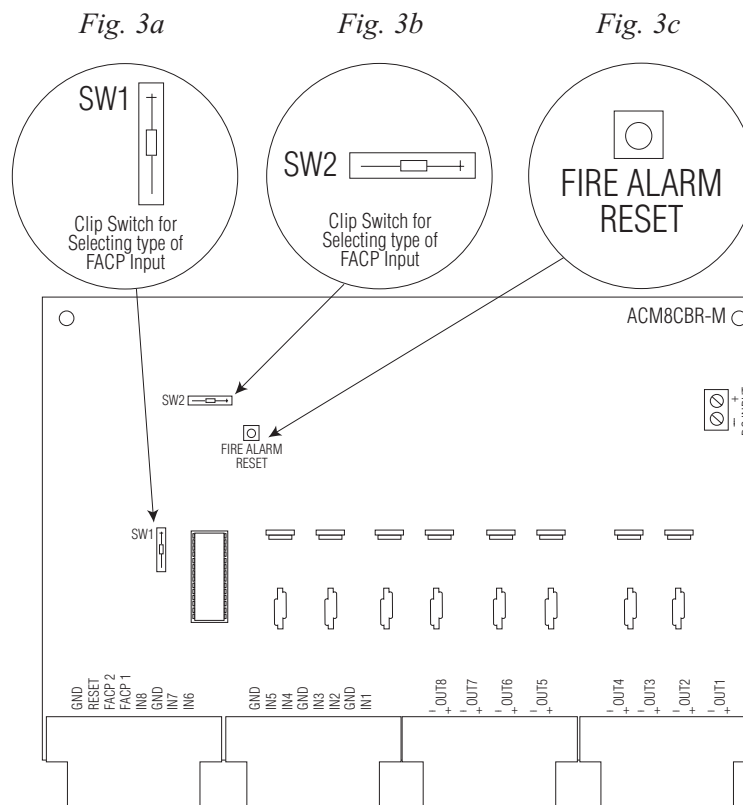

Fig. 3



Power Supply Board

Maximal1RHD, Maximal1RD

Fig. 4

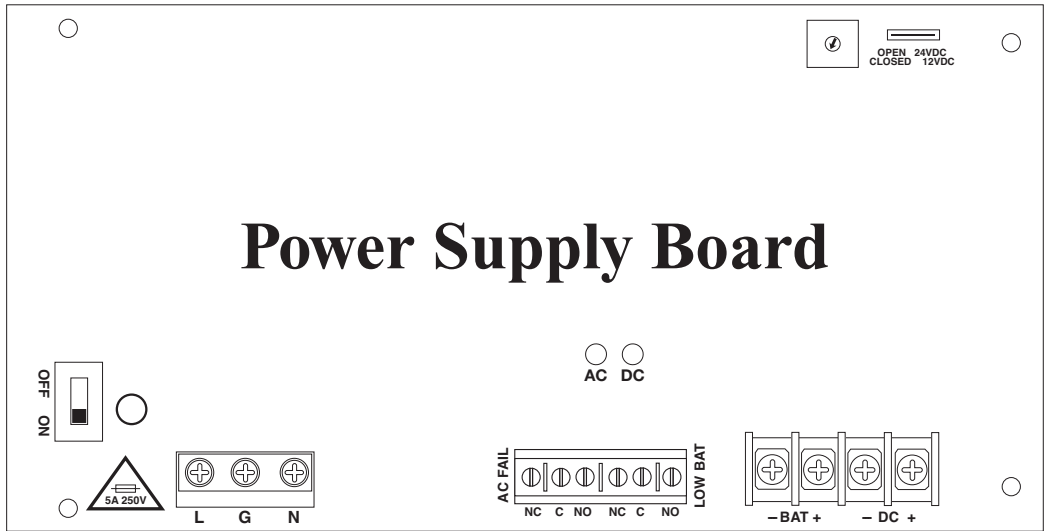

Fig. 4a

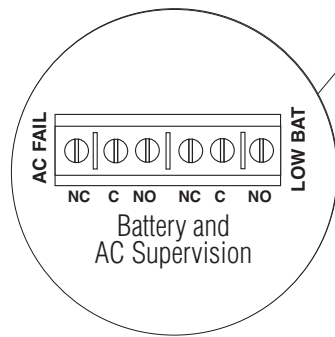
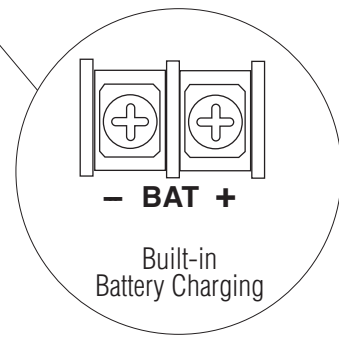

Fig. 4b



Power Supply Board

Maximal3RHD, Maximal3RD, Maximal33RD

Fig. 5

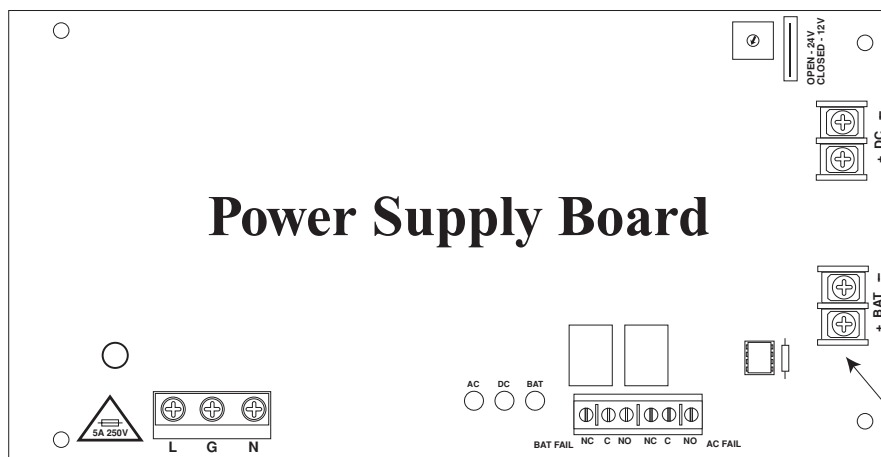

Fig. 5a

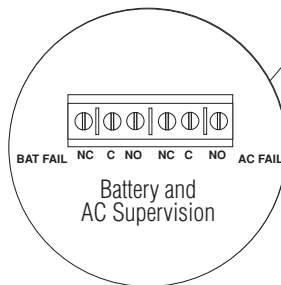
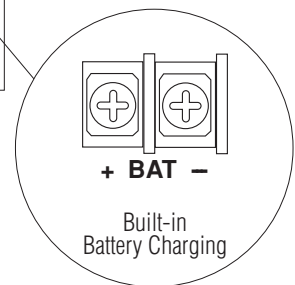

Fig. 5b



FACP Hook-Up Diagrams

Polarity Reversal Input from FACP Signal Circuit Output (Polarity is referenced in alarm condition)

Fig. 6

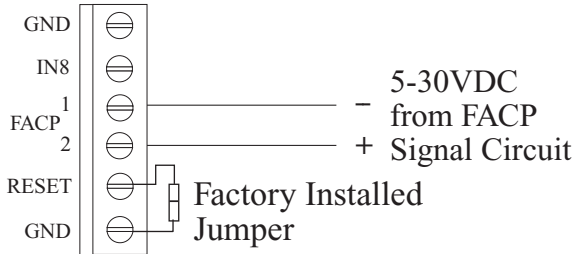

Non-Latching

Fig. 7

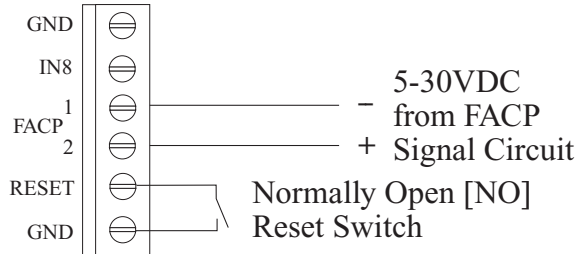

Latching

Normally Closed Input from FACP

Fig. 8

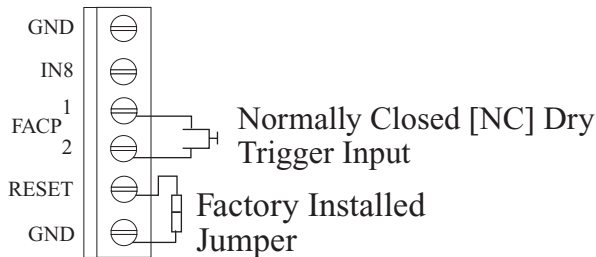

Non-Latching

Fig. 9

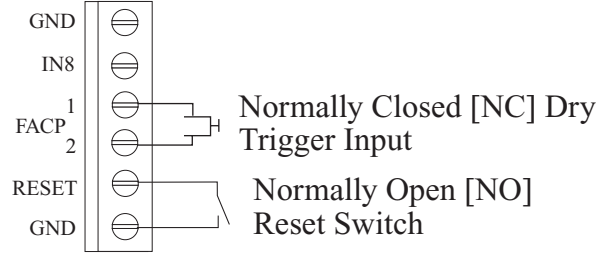

Latching

Normally Open Input from FACP

Fig. 10

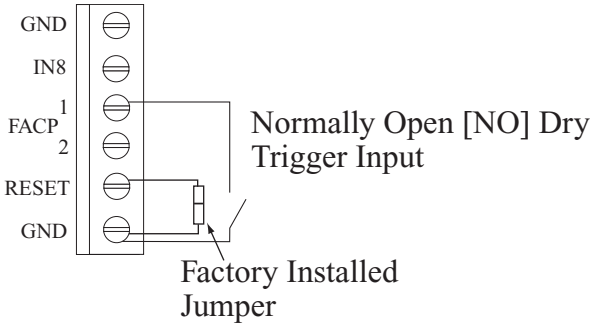

Non-Latching

Fig. 11

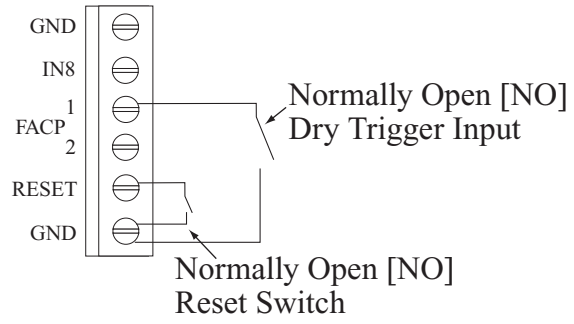

Latching

Mounting Options:

Fig. 12

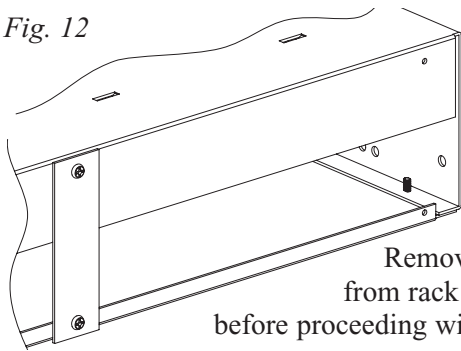

Mounting Hardware (Included):

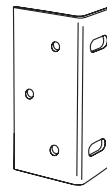

Ⓐ Two (2) mounting brackets.



Ⓑ Eight (8) flat head screws for mounting brackets.

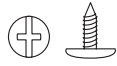

Ⓒ Eight (8) pan head screws for faceplate.

Rack Mount Installation

1. Remove center brace from rack mount chassis (Fig. 12, pg. 10).
2. Slide mounting brackets (A) into slots located on left and right side of rack enclosure (Fig. 13a). Use three (3) flat head screws (B) to secure brackets.
3. Carefully place faceplate over LED's, and secure using three (3) pan head screws (C) on top and three (3) pan head screws (C) on the bottom of faceplate (Fig. 13b, pg. 10).
4. Slide unit into desired EIA 19" rack position and secure with mounting screws (not included) (Fig. 13c, pg. 10).

Fig. 13

Fig. 13a

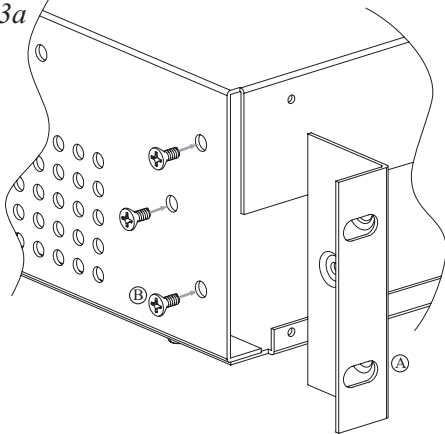

Fig. 13b

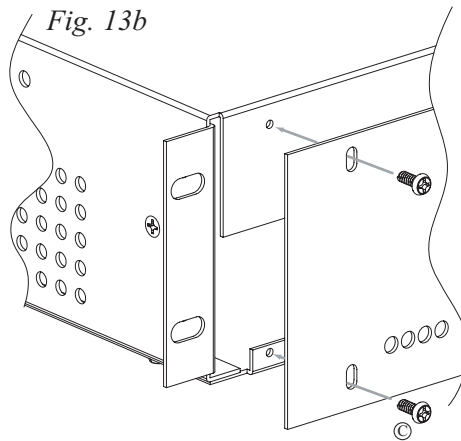
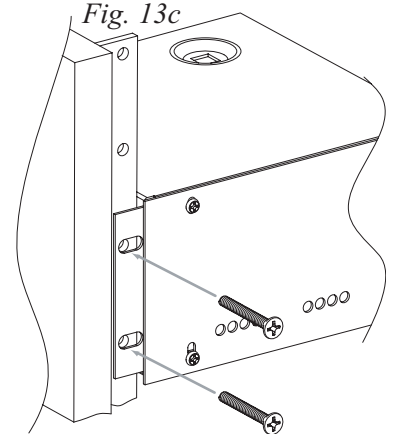

Fig. 13c



Wall Mount Installation

1. Carefully place faceplate over LED's, and secure using three (3) pan head screws (C) on top and three (3) pan head screws (C) on the bottom of faceplate (Fig. 14a).
2. Place mounting brackets (A) onto the side of the left and right side of rack enclosure (Fig. 14b). Use three (3) flat head screws (B) to secure mounting brackets.
- 3- Mount rack and secure with mounting screws (not included) (Fig. 14c).

Fig. 14

Fig. 14a

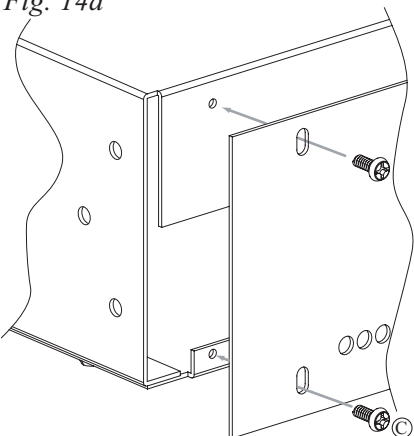

Fig. 14b

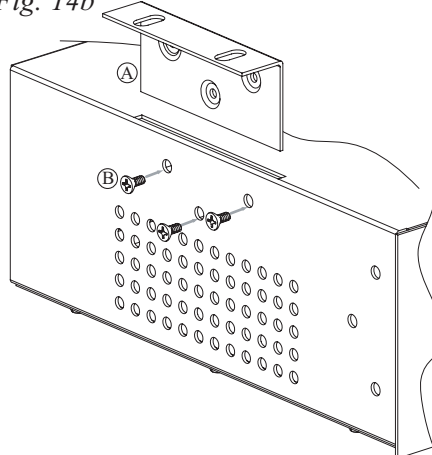
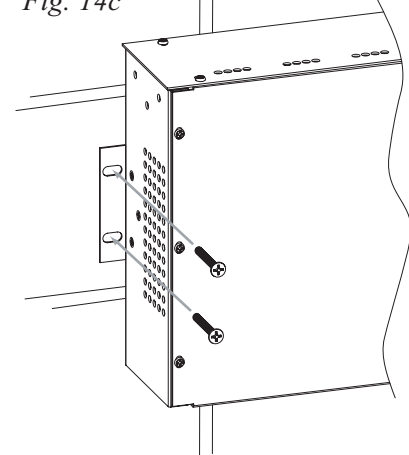

Fig. 14c



Rack Mechanical Drawing & Dimensions

3.25"H x 19.125"W x 8.5"D

Fig. 15

Fig. 15a

Fig. 15b

Fig. 15c

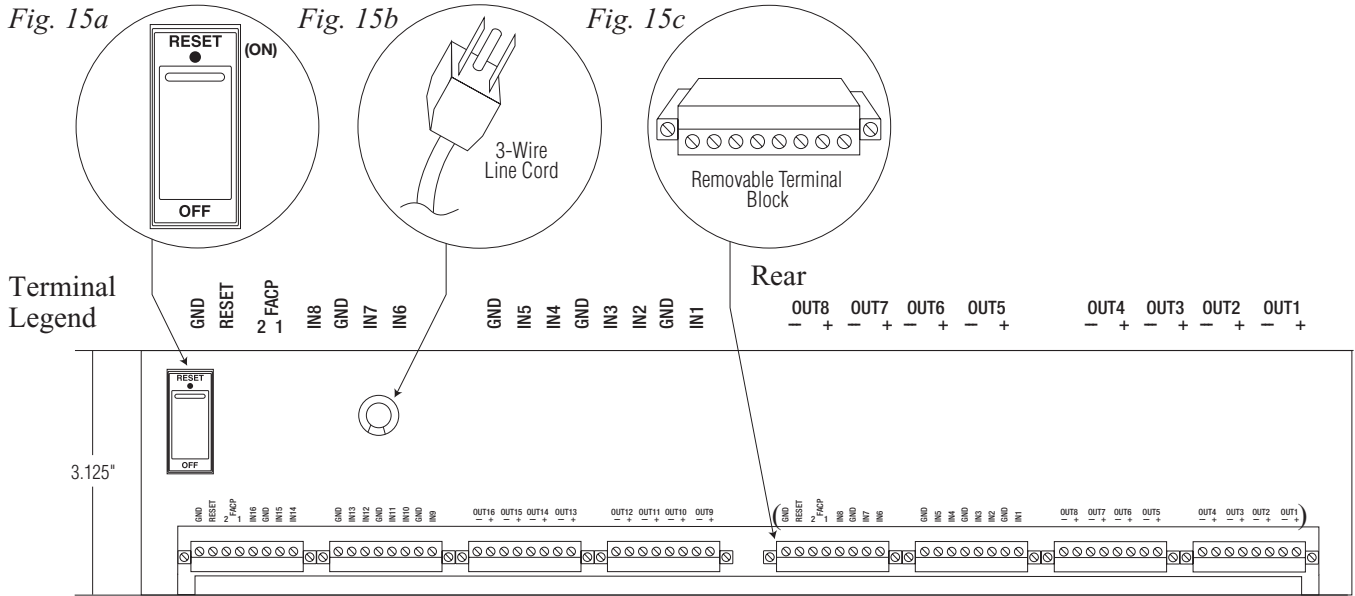

3.125"

Bottom

17.625"

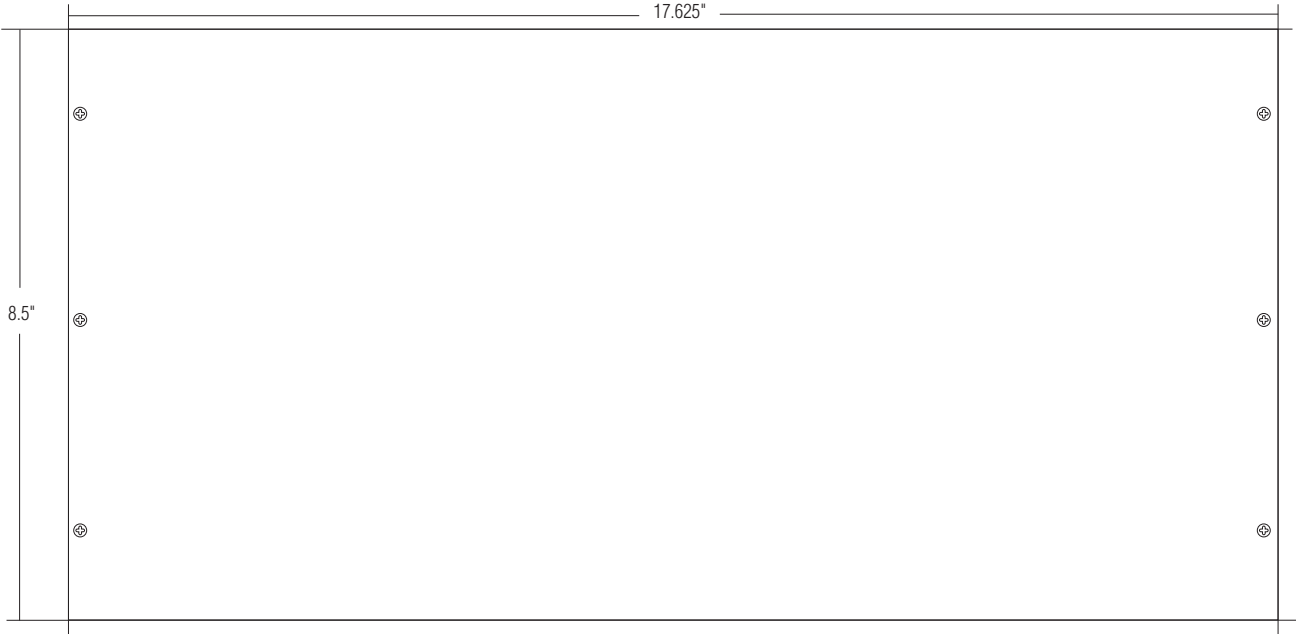

Front

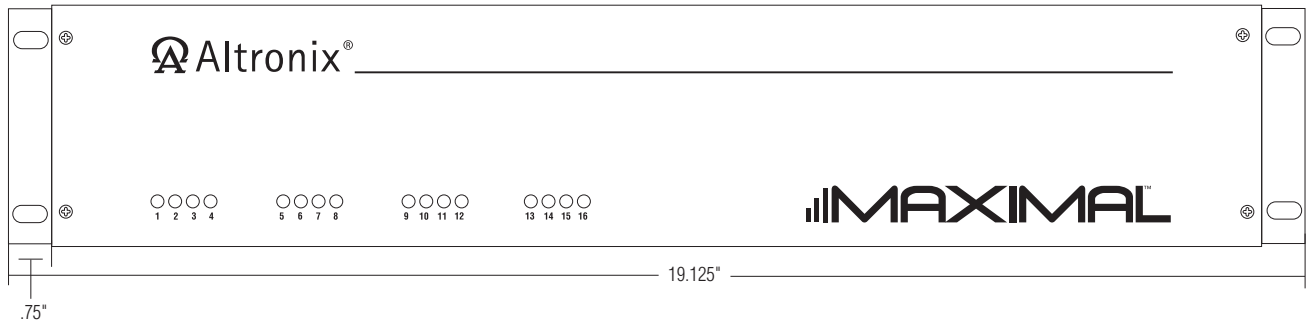

Notes:

Altronix is not responsible for any typographical errors.

Altronix Corp.
140 58th Street, Brooklyn, New York 11220 USA, 718-567-8181, fax: 718-567-9056
web site: www.altronix.com, e-mail: info@altronix.com, Lifetime Warranty, Made in U.S.A.
II MaximalDRackMountSeries K10K

