

SDC Security Door Controls

801 Avenida Acaso, Camarillo, Ca. 93012 • (805) 494-0622 •
www.sdcsecurity.com • E-mail: service@sdsecurity.com

INSTALLATION INSTRUCTIONS 920P EntryCheck™

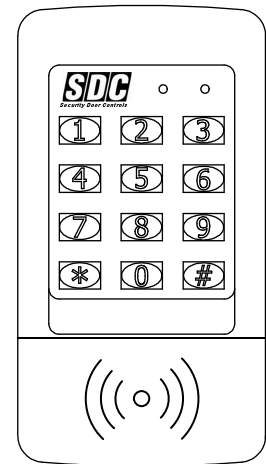

The *EntryCheck™* 920P Indoor/Outdoor Keypad is a surface-mount digital keyless entry system designed for access control applications. The backlit keys are bright and easy-to-read. A heavy cast vandal resistant housing design with mounting plate allows the 920P to be mounted on a rugged surface or on a standard single-gang electrical box.

The 920P has a capacity of 500 users. Users can be assigned to use 4 to 6 digit PIN codes and/or HID proximity access cards. An authenticated access can be programmed to activate one or both of the relay outputs.

The timed “anti-passback” feature prevents using the same credentials twice before a programmed waiting period has elapsed.

Two long lasting solid state LED indicators show the status of the system. The left bi-color indicator lights red to indicate power, then green when access is granted. The right indicator flashes yellow to indicate that the keypad is in programming mode.

An internal sounder can be programmed to beep each time a key is pressed or when an output is activated. An internal jumper sets the sounder volume high or low

The **SENSE** input can be configured two ways through programming. When configured for “Door Sense”, the input is wired to a normally closed door position switch to detect when the door is opened or closed. Forced entry or door ajar situations can then be detected. The “Auto-relock” feature can also be used to turn off the Main Relay output immediately when the door is closed after access has been granted to prevent “tailgating”. When the **SENSE** input is configured for “Inhibit”, the input can be wired to a normally open “service” switch or automatic timer that will disable access while the switch is closed.

The **REQUEST-TO-EXIT** input can be wired to a normally open pushbutton to provide codeless activation of the Main Relay, Auxiliary Relay, Output #3 or Output #4 (programmable).

The **ALARM SHUNT** signal is available when access is granted. This signal can be programmed to activate any of the relays or solid state outputs to shunt alarm contacts on the access door/gate preventing the triggering of an alarm when an authorized access occurs.

The 920P *EntryCheck™* is powered from a 12-24V AC or DC source. The non-volatile EEPROM memory retains entry codes and programming when power is removed. An internal jumper is provided to reset the master code. The Main Relay has a 5 Amp capacity. The Auxiliary Relay has a 2 Amp capacity. Two solid state outputs, capable of sinking 100 mA to common are programmable for alarm shunting, or to signal forced entry, door ajar, keypad lockout, request-to-exit, and keypad active conditions.

Features

- Keypad programmable
- 500 user codes
- 3 User Modes
 - PIN or Card
 - Card Only
 - Card and PIN
- 4 to 6 digit user codes
- 4 independent outputs
- 4 independent timers
- 2 Form C relay contacts
- 2 solid state open collector outputs
- Program entry codes to activate one or two relays
- Disable input
- Door sense input
- Request-to-exit/Reception input
- Keypad tamper lockout
- Timed anti-passback
- Anti-tailgate
- Two LED status indicators
- Tactile key feel
- Audible code entry verification
- 12V or 24V, AC or DC operation

SPECIFICATIONS

Mechanical

Dimensions: 3.00" W x 5.75" H x 1.375" D
(1.4375" wall projection)

Electrical

Input Voltage: 12-24 Volts AC or DC
Operating Current: 30 mA typical, 150 mA max

Output Ratings

Main Relay: Form “C” 5 Amps @ 28 Volts max
Auxiliary Relay: Form “C” 2 Amp @ 28 Volts max
Type: Solid state outputs (Outputs #3 & #4)
Short-to-common 100 mA @ 24 VDC maximum

Environmental

Temperature: -22°F to 149°F (-30°C to 65°C)
Humidity: 5% to 95% non-condensing

QuickStart Programming

You must first enter programming mode to perform any function. The yellow indicator will blink slowly showing that the 920P EntryCheck™ is in programming mode. Use the option codes to program each function. After the new data entry is complete for each function, the yellow indicator will flash quickly while the data is being stored and the green indicator will light briefly if the programming has been accepted. The red indicator will light if any programming data is entered incorrectly or the function is rejected. If a red indicator is seen, the entire function (option code + data) will have to be fully re-entered. The keypad will remain in programming mode until **** #** is pressed or after 30 seconds of inactivity.

Set default parameters (first time use)

- Step 1. Enter: **#9# 123456#** Enter programming mode (default master code=123456)
- Step 2. Enter: **03# 4#** Set the entry code length to 4 digits
- Step 3. Enter: **21# 5#** Set the main relay activation time for 5 sec.
- Step 4. Enter: **** #** Exit programming mode

Assign a user (Card only)

- Step 1. Enter: **#9# 123456#** Enter programming mode (default master code)
- Step 2. Enter: **06# 002# 9876# 9876# 1# (Present card)** Assign card to User 002 with a PIN code of '9876'. Activate the main relay when validated.
- Step 3. Repeat Step 2 to enter another unique user & card, or continue to Step 4.
- Step 4. Enter: **** #** Exit programming mode.

Assign a user (PIN only)

- Step 1. Enter: **#9# 123456#** Enter programming mode (default master code)
- Step 2. Enter: **01# 003# 2580# 2580# 1#** Assign User 003 with a PIN code of '2580'. Activate the main relay when entered.
- Step 3. Repeat Step 2 to enter another unique user & PIN or continue to Step 4.
- Step 4. Enter: **** #** Exit programming mode

Test your new user

Present your card or enter an authorized PIN code + #. The green indicator should illuminate and the main relay should activate, unlocking the door for 5 seconds.

Deleting a user code

- Step 1. Enter: **#9# 123456#** Enter programming mode (default master code)
- Step 2. Enter: **02# 002# 002#** User 002 has been deleted.
- Step 3. Enter: **** #** Exit programming mode

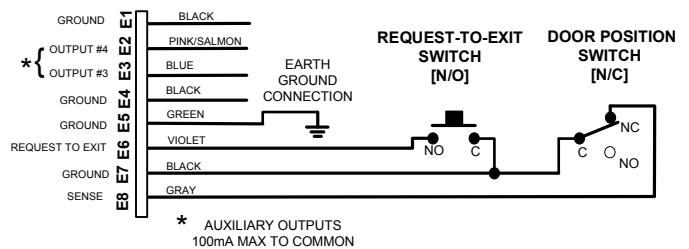
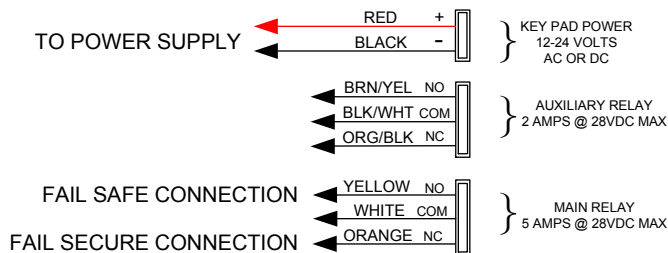
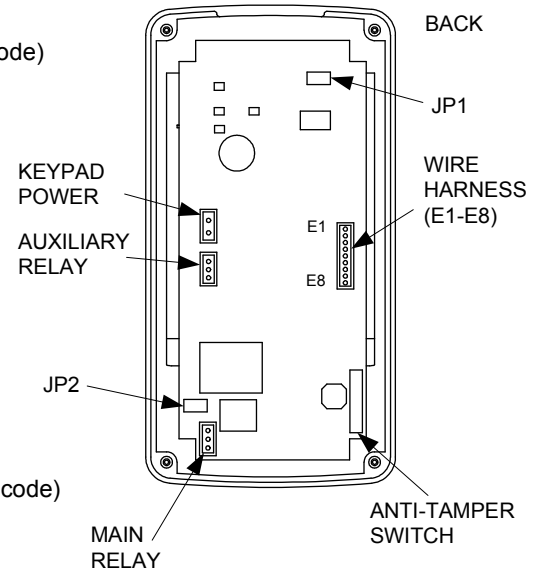
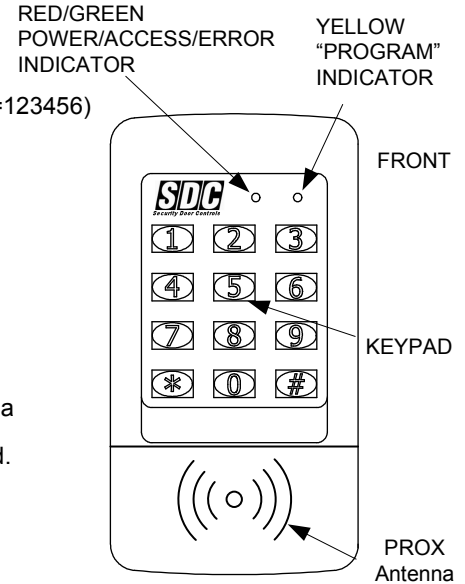

Fig. 2 Wiring Pigtail Color Code



CAUTION
IF THE UNIT IS AC POWERED, MAKE SURE THAT THE SECONDARY OF THE SYSTEM IS ISOLATED FROM EARTH GROUND

KEYPAD WIRING

See Fig. 3 for an example of a basic door installation. The keypad is mounted adjacent to the door. An electric door strike is mounted in the door jamb to release the door lock. A magnetic switch is mounted on top of the door jamb for detecting when the door is open.

Use the following steps to wire the keypad. Refer to the wiring diagram shown in Fig. 4 to assist in the wiring.

Note: Up to 500 feet of 18 AWG wire can be run for power, use larger wire for longer runs. Use 22 AWG or larger (depending on load) for other connections. Refer to lock manufacturer's documentation for recommended lock power AWG.

Output Connection

Install a low voltage fail secure (power to unlock) electric door strike at the door to be controlled. Route two wires from the door strike to the keypad. Connect a MOV or varistor across the coil wires of the strike. Connect the (+) door strike wire to the keypad's MAIN RELAY N.O wire (yellow). Connect the other door strike wire to the keypad's PWR(-) wire (black). Connect the keypad's MAIN RELAY COM wire (white), to the keypad's PWR(+) wire (red).

Power Connection

Choose a location for the DC power supply or AC transformer. Route two wires between the door strike and the keypad. Connect the power supply's output terminals to the keypad's PWR(+) wire (red) and PWR(-) wire (black). If using a DC supply, observe wiring polarity. If an AC transformer is being used, polarity does not matter.

Caution: If the unit is AC powered, make sure the secondary of the system transformer is isolated from earth ground.

Earth Ground

To avoid damage to the unit from static discharges, connect the earth ground wire (green/E5) to a good earth grounding point. Suggested wiring size is 18 AWG for earth ground.

Sense Input

RE Note: The SENSE input (gray wire) can be programmed as either a door sense or inhibit input. Both features cannot be used at the same time. If you are not using the sense input, program this input for inhibit.

Door Sense: (Detect forced entry or door ajar conditions) Install a normally closed door switch on the door and route two wires from the switch to the keypad. Connect the door switch to the keypad's SENSE wire (gray/ E8) and COM wire (any black wire).

Inhibit: (Disable access) If an inhibit switch or timer is going to be used for temporarily disabling the keypad, route two wires from the switch or timer to the keypad. Connect the inhibit switch/timer's normally open contacts to the keypad's SENSE (gray/ E8) and COM (black wires) terminal.

Request-to-Exit Input (wiring shown on page 3, fig. 4)

If a request-to-exit pushbutton is going to be used, route two wires from the keypad box to a normally open pushbutton mounted on the secure side of the door. Connect the wires to the pushbutton and to the keypad's REX wire (violet/ E6) and COM (black wires) terminals.

Solid State Outputs

The two solid state outputs (Outputs #3 & #4) can be programmed to activate during various conditions. These "open collector" outputs can be used to activate indicators or sounders. See fig. 5 for wiring examples using the solid state outputs.

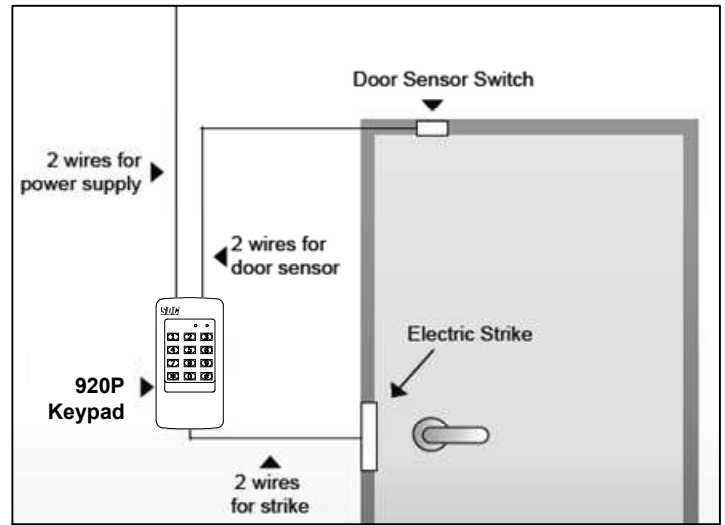

Fig. 3 Basic Door Installation

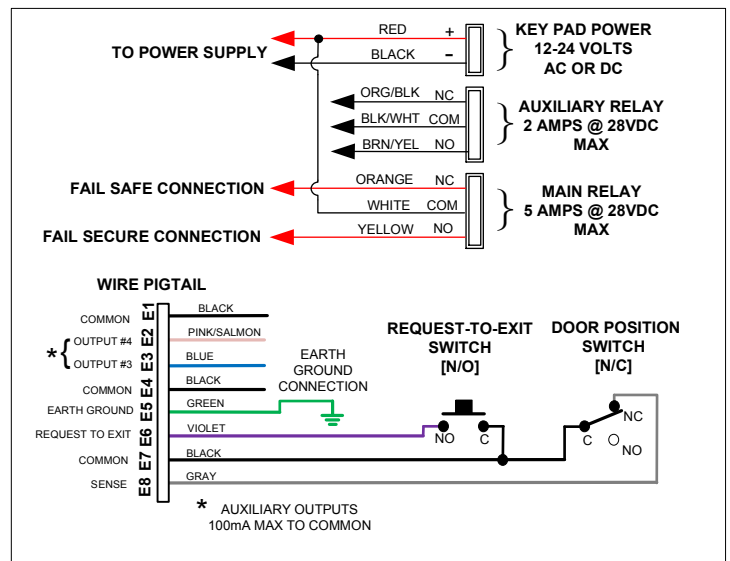

Fig. 4 Basic Door Installation Wiring

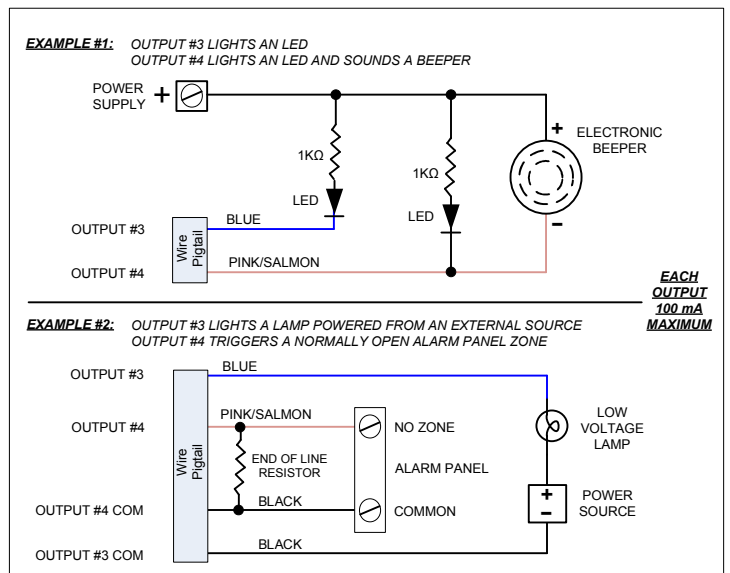

Fig. 5 Using Solid State Outputs

FACTORY DEFAULTS

Master Programming Code.....	123456
Entry Code Length.....	4 digits
Entry Mode.....	Card or PIN
Request-to-exit Output Relay.....	Main Relay
Alarm Shunt Output.....	Disabled
Forced Entry Output.....	Output #3
Door Ajar Output.....	Output #4
Main Relay On Time.....	02 Seconds
Auxiliary Relay On Time.....	02 Seconds
Solid State Output #3 On Time.....	02 Seconds
Solid State Output #4 On Time.....	02 Seconds
Door Sense/Inhibit Input.....	Door Sense
Keypad Lockout Output.....	Disabled
Keypad Active Output.....	Disabled
Beeper Sounds When Key Pressed.....	Yes
Beeper Sounds During Relay #1.....	No
Beeper Sounds During Relay #2.....	No
Beeper Sounds During Output #3.....	No
Beeper Sounds During Output #4.....	No
Keypad Lockout Count.....	3 Tries Before Lockout
Anti-Passback Time.....	No Anti-Passback
Auto-Relock.....	On

BASIC PROGRAMMING

When the 920 EntryCheck™ is in Programming Mode, the yellow indicator will blink. This shows that the 920 is ready to accept the new programming data. After the new data entry is complete, the yellow indicator will flash while the data is being stored. The green indicator will light if the data is accepted. The red indicator will light if any programming data is entered incorrectly, and the command will have to be fully re-entered.

Entering Programming Mode

The 6-digit Master Programming Code (default = 123456) is used to enter Programming Mode.

Press: # 9 # Master Code #

Master Code = the current 6-digit Master Programming Code

Exiting Programming Mode

Press: ** #

The red indicator will light after exiting Programming Mode

Note: The 920P will automatically exit Programming Mode after two minutes of inactivity

Re-entering a Command After a Mistake

If the red indicator lights, signaling an incorrect entry, or an incorrect key is pressed during programming, to clear the keypad and re-enter the command:

Press: * 9 #

Setting Entry Code Length **Default: 4 digits**

Press: 03 # Length #

Length = 4-6 for entry code length

Note: If the Entry Code Length is going to be changed from the factory default of 4 digits, make this change first before programming any entry codes.

Select Entry Mode **Default: Card or PIN**

Sets the entry mode for the 920P.

Press: 05 # Mode #

Mode=Operating Mode(1-3)

1=Card or PIN; 2=Card Only 3=Card and PIN

Adding a New User

User PIN Only Access (No Card)

Press: 01 # User # Code # Code # Relay #

---- Or ----

User Card and or PIN Access

Press: 06 # User # Code # Code # Relay # Present Card

User=3-digit User number to be added: 001-500

Code=The new entry code: 1-999999, depending on code length

Relay=Relay output entry code will activate:

1=Main Relay 2=Auxiliary Relay 3=Both Relays

10=Relay #1, toggled 20=Relay #2, toggled 30=both Relays toggled

12=Relay #1 toggled; Relay #2 timed open

21=Relay #1 timed open; Relay #2 toggled

The yellow indicator will flash quickly while the 920P stores the new user information in memory. The green indicator will light when the new code and card are accepted. If the user number already exists or an entry error has been made, the red indicator will light. Delete the user and re-enter the new information again.

Note: Leading zeros (zeros before the code number, i.e.0001) do not need to be entered when programming a new code. The 920 will internally add any zeros to fill digits determined by the entry code length setting. Leading zeros will have to be entered by the user when entering their code to gain access.

Output Toggle Mode

When an output is programmed for Toggle Mode, the output alternates from OFF to ON or from ON to OFF each time it is accessed. When an output is toggled on, the green LED remains solid until toggled off.

The rules for a toggle output are:

- *If the output is OFF, it will turn ON and stay on until the next activation.*
- *If the output is ON, it will turn OFF and stay off until the next activation.*
- *An authorized PIN, Card, or REX input programmed to momentarily activate that same relay will reset the relay to its normal state.*

Adding Multiple Cards

Press: 07 # 1st User # Code # Code # Relay # Number of users # Present 1st card

1st User =Starting user number to add

Number of users = Total number of consecutive cards to add

The yellow indicator will flash quickly while the 920P erases the user from memory. The green indicator will light when the codes have been added.

Erasing a Single User

Press: 02 # User # User #

User =The user number to delete 002-500

The yellow indicator will flash quickly while the 920P erases the user from memory. The green indicator will light when the code is erased.

Erasing Multiple Users (Sequential)

Press: 09 # 1st User # Number of users #

1st User =Starting user number to delete

Number of users = Total number of consecutive users to delete

The yellow indicator will flash quickly while the 920P erases the user from memory. The green indicator will light when the code is erased.

(Typical Programming cont.)

Program all normal entry codes to use the Main Relay (Relay #1), and only Relay #1 as the output relay. Program the code(s) that you want to use to hold the output for an indefinite period to the Auxiliary Relay (Relay #2). See the following example that sets entry codes 1234 for normal and 5678 for toggle operation.

Press: 01 # User # 1 2 3 4 # 1 2 3 4 # 1 #
01=Programming Step; 1234=Entry Code; 1=Main Relay

Press: 01 # User # 5 6 7 8 # 5 6 7 8 # 20 #
01=Programming Step; 5678=Entry Code; 20=Auxiliary Relay toggle

Typical Toggle Mode Wiring

For devices triggered by a normally open circuit, wire the contacts of the Main and Auxiliary Relays in parallel (see the Figure below). Either relay will be able to trigger the access device. Entry codes programmed for the Auxiliary Relay will be able to hold the output on.

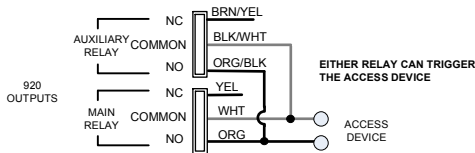

Configure Sense Input **Default: Door Sense**

The Sense Input (gray wire) can be programmed for either DOOR SENSE or INHIBIT.

Press: 10 # Input #
Input=0 for Door Sense; =1 for Inhibit

When programmed for DOOR SENSE, if an open condition on the input occurs before access is granted (with an entry code or with the request-to-enter input) a FORCED ENTRY output will occur. If an open condition remains 60 seconds after a relay activation for access, a DOOR AJAR output will occur.

When programmed for INHIBIT, a closed condition on the input will prevent Relay #1 from activating when access is requested with an entry code. This mode is typically used with an external timer to disable the access device at certain times.

Select Forced Entry Output **Default: No Output**

Sets which output activates if the DOOR SENSE input opens before access is granted. This output is timed and configured by the relay "On-time".

Press: 11 # Output #
Output=Output to Activate(0-4)
1=Main Relay; 2=Auxiliary Relay; 3=Output #3; 4=Output #4;
0=No Output

Select Door Ajar Output **Default: No Output**

Sets which output activates if the DOOR SENSE input stays open 60 seconds after access is granted (door ajar time is adjustable using Function 25). This output is not timed.

Press: 12 # Output #
Output=Output to Activate (0-4)
1=Main Relay; 2=Auxiliary Relay; 3=Output #3; 4=Output #4;
0=No Output

Select Keypad Lockout Output **Default: No Output**

Sets which output activates when the keypad is "locked out" after too many incorrect entry code attempts. The lockout time is 60 seconds.

Press: 13 # Output #
Output=Output to Activate (0-4)
1=Main Relay; 2 = Auxiliary Relay; 3=Output #3; 4=Output #4;
0=No Output / Lockout Disable

Select Keypad Active Output **Default: No Output**

Sets which output activates when any keys are pressed. This output is timed. If toggle mode is selected for the output, the timer value defaults to 2 seconds.

Press: 14 # Output #
Output=Output to Activate(0-4)
1=Main Relay; 2=Auxiliary Relay; 3=Output #3; 4=Output #4;
0=No Output

Select Alarm Shunt Output **Default: No Output**

Sets which output activates during the time access is granted. (Use this output of shunt alarm contacts attached to the access door.) This output may be timed or toggled.

Press: 15 # Output #
Output=Output to Activate(0-4)
1=Main Relay; 2=Auxiliary Relay; 3=Output #3; 4=Output #4;
0=No Output

Select Request-to-Exit Output **Default: No Output**

Sets which output activates when the Request-to-Exit input is grounded. This output may be timed or toggled.

Press: 16 # Output #
Output=Output to Activate(0-4)
1=Main Relay; 2=Auxiliary Relay; 3=Output #3; 4=Output #4;
0=No Output
REX input terminates toggle of Main or Aux. Relay

Anti-Tamper Output **Default: No Output**

Sets which output activates when the Anti Tamper switch on the back of the keypad is activated.

Press: 17 # Output #
Output=Output to Activate(0-4)
0=No Output; 2=Auxiliary Relay; 3=Output #3; 4=Output #4;

Main Relay On-time **Default: 02 Seconds**

Sets the length of time the Main Relay activates when triggered. Green LED is on when Main Relay is active.

Press: 21 # Seconds #
Seconds=Output time in seconds (1-60)

Auxiliary Relay On-time **Default: 02 Seconds**

Sets the length of time the Auxiliary Relay activates when triggered.

Press: 22 # Seconds #
Seconds=Output time in seconds (1-60)

Solid-state Output #3 On-time **Default: 02 Seconds**

Sets the length of time Output #3 activates when triggered.

Press: 23 # Seconds #

Seconds=Output time in seconds (1-60), 99=Toggle Mode

Solid-state Output #4 On-time **Default: 02 Seconds**

Sets the length of time Output #4 activates when triggered.

Press: 24 # Seconds #

Seconds=Output time in seconds (1-60), 99=Toggle Mode

Door Ajar Timer **Default: 60 Seconds**

Sets the amount of time the door may be held open after an authorized access. The DOOR AJAR output will activate after the time expires.

Press: 25 # Seconds #

Seconds=Output time in seconds (1-60), 99=Toggle Mode

Beep Sounds on Keystrokes **Default: Yes**

Selects whether or not the keypad beeps as each key is pressed.

Press: 40 # Sound #

Sound=1 for Yes, =0 for No

Beep Sounds During Main Relay **Default: No**

Selects whether or not the keypad beeps during Main Relay activation.

Press: 41 # Sound #

Sound=1 for Yes, =0 for No

Beep Sounds During Auxiliary Relay **Default: No**

Selects whether or not the keypad beeps during Auxiliary Relay activation.

Press: 42 # Sound #

Sound=1 for Yes, =0 for No

Beep Sounds During Output #3 **Default: No**

Selects whether or not the keypad beeps during Output #3 activation.

Press: 43 # Sound #

Sound=1 for Yes, =0 for No

Beep Sounds During Output #4 **Default: No**

Selects whether or not the keypad beeps during Output #4 activation.

Press: 44 # Sound #

Sound=1 for Yes, =0 for No

Beep Sounds Anti-Tamper Activation **Default: No**

Selects whether or not the keypad beeps during Anti-Tamper switch activation.

Press: 45 # Sound #

Sound=1 for Yes, =0 for No

Keypad Lockout Count **Default: 3 Attempts**

Sets the number of incorrect entry code attempts allowed before the keypad "locks out" for 60 seconds.

Press: 50 # Attempts #

Attempts=Number of attempts before lockout (2-7)

**Refer to Option 13 to Enable Lockout Feature*

Anti-Pass Back Time **Default: No Anti-Pass Back**

Sets the length of time an entry code will not function after it is used.

Press: 51 # Minutes #

Minutes=Time in minutes (2-4), 0=No Anti-passback

Selects mode for Keypad LED Backlight **Default: 30 Seconds**

Selects whether or not the keypad back light stays OFF, lights for 30 seconds when activated or stays ON.

Press: 52 # Output #

0 = Light always OFF

1 = 30 sec light when activated (default)

2 = Light always ON

Changing the Beeper Sound Level

The Keypad's beeper can be set to high or low level. Remove jumper JP1 to reduce beeper sound level.

Changing the 6-Digit Master Programming Code

Press: 98 # Master Code # Master Code #

Master Code=The new 6-digit Master Programming Code

RESETTING KEYPAD

Master Reset

CAUTION: Performing a master reset will clear the entire memory of the 920P and return all programmable options to the factory default values. ALL ENTRY CODES WILL BE ERASED. NOTE: The Master Code will NOT be reset.

- STEP 1** Disconnect power from the keypad.
- STEP 2** Press and hold down the * and # keys.
- STEP 3** Apply power to the keypad, continue holding the keys down until the red indicator starts flashing
- STEP 4** Release the keys. The red and yellow indicators will remain lit until the process is complete, then the yellow indicator will go out.

Resetting the Master Code

- STEP 1** Remove the 920P from the wall and disconnect power from the keypad.
- STEP 2** Locate & Remove jumper at JP2. Reference page 2.
- STEP 3** Re-apply power. You will get a single beep and the yellow LED will flash momentarily.
- STEP 4** Replace jumper on JP2.

THE MASTER PROGRAMMING CODE IS NOW 123456.

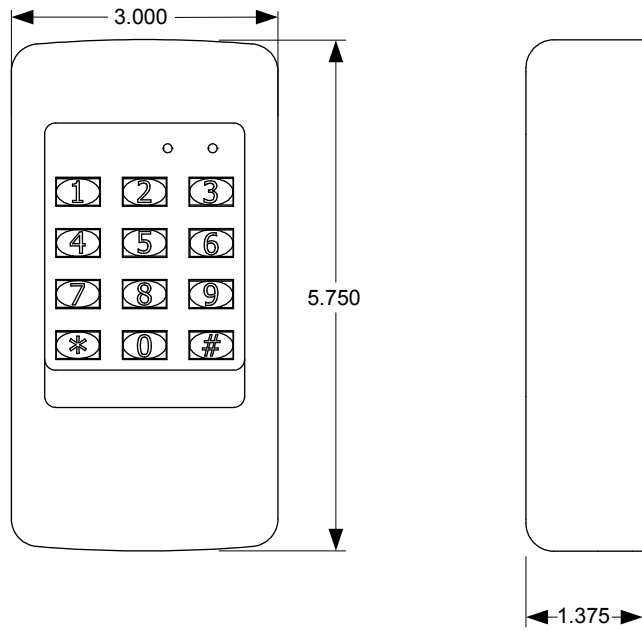

SURFACE MOUNT

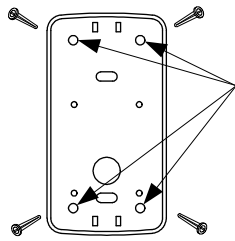

4X Mount at holes
With supplied
screws and hole
expansion anchors

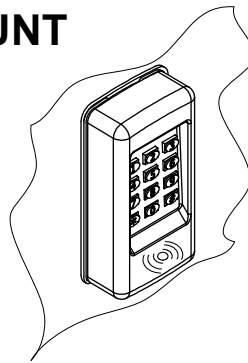

MOUNTING TO SINGLE GANG RECESSED OUTLET BOX

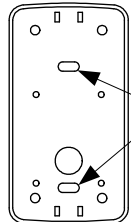

2X
Mount
at slots

