

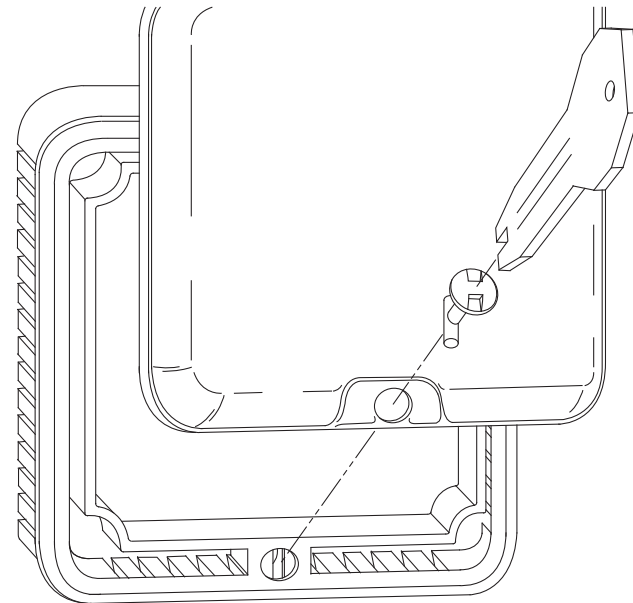

Safety Technology International, Inc.
2306 Airport Road • Waterford, Michigan 48327-1209
Phone: 248-673-9898 • Fax: 248-673-1246
Toll Free: 800-888-4784 • E-mail: info@sti-usa.com
Web: www.sti-usa.com

Safety Technology International (Europe) Ltd.
Unit 49G Pipers Road • Park Farm Industrial Estate • Redditch
Worcestershire • B98 0HU • England • Tel: 44 (0) 1527 520 999
Fax: 44 (0) 1527 501 999 • Freephone: 0800 085 1678 (UK only)
E-mail: info@sti-europe.com • Web: www.sti-europe.com

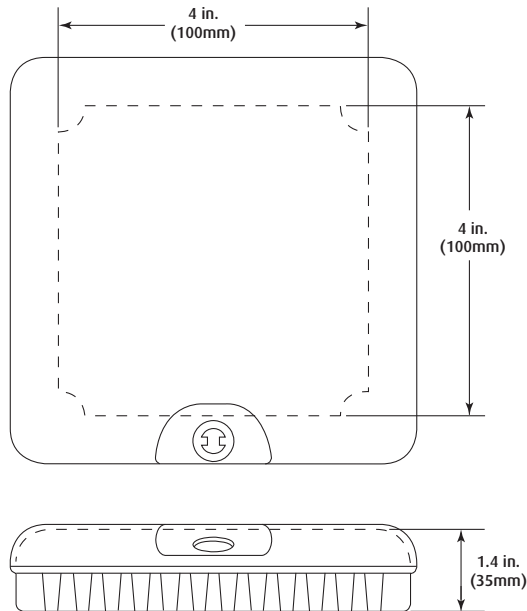

INSTALLATION INSTRUCTIONS

1. Do not remove thermostat. Prior to drilling anchor holes, cover thermostat with a damp cloth to prevent dust from penetrating the sensor.
2. Center frame over existing thermostat. Mark and drill (4) anchor holes using a 1/4 in. (6.3mm) drill bit. Insert the (4) anchors and complete installation as shown.

NOTE: The (3) tabs on the frame must face upward (View A).

3. Insert the (3) slots on the cover over tabs on the top surface of frame. Rotate cover downward onto the frame and turn key to lock.

CLEANING INSTRUCTIONS

To clean cover, remove from wall. Rinse with water to remove abrasive dust and dirt. Wash with soap or mild detergent using a soft cloth (DO NOT SCRUB). Rinse once more, then dry with a soft cloth or chamois. To remove grease or wet paint, rub gently with a cloth wetted thoroughly with naphtha. Then wash and rinse. DO NOT USE RAZOR BLADES.

Electronic warranty form at www.sti-usa.com/wc14

INSTALLATION OF STI-9102 THERMOSTAT COVER

All specifications and information shown were current as of publication and are subject to change without notice.

9102IS JULY2011

