



**Safety Technology International, Inc.**  
 2306 Airport Road • Waterford, Michigan 48327-1209  
 Phone: 248-673-9898 • Fax: 248-673-1246  
 Toll Free: 800-888-4784 • E-mail: info@sti-usa.com  
 Web: www.sti-usa.com

**Safety Technology International (Europe) Ltd.**  
 Unit 49G Pipers Road • Park Farm Industrial Estate • Redditch  
 Worcestershire • B98 0HU • England  
 Tel: 44 (0) 1527 520 999 • Fax: 44 (0) 1527 501 999  
 E-mail: info@sti-europe.com • Web: www.sti-europe.com

### INSTALLATION OF CABINET

1. Insert the (5) mounting tabs fully into back box mounting tab slots. Use rubber mallet if necessary.
2. After selecting a suitable location, place cabinet in closed position, against the wall. Mark and drill (5) 1/4 in. diameter holes. Insert the (5) 19033 anchors.
3. Select (1) of the (2) shelf mounting locations, install shelf. Close and lock cabinet.
4. Place cabinet in position making sure the (2) switch wires are not pinched between the wall and cabinet. Drive in the (5) screws. Cabinet is now secure.

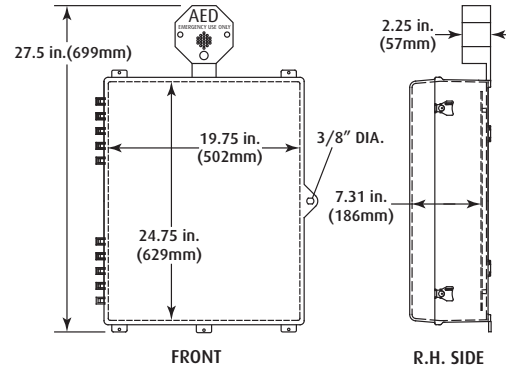

STI-7553AED

### INSTALLATION OF ALARM ASSEMBLY

1. Place the alarm mounting plate on the top center of cabinet. Select at least two of the four optional mounting holes. Mark and drill 3/16 in. holes and install the 19018 anchors.
2. Fish the magnetic switch wires through the alarm mounting plate and the siren backplate (View A). Next, drive the two alarm mounting screws into the previous installed anchors.
3. Install the two magnetic switch wires following the terminal switch diagram (View B on reverse side).
4. Install the alarm cover using the (2) tamperproof screws and provided tool.

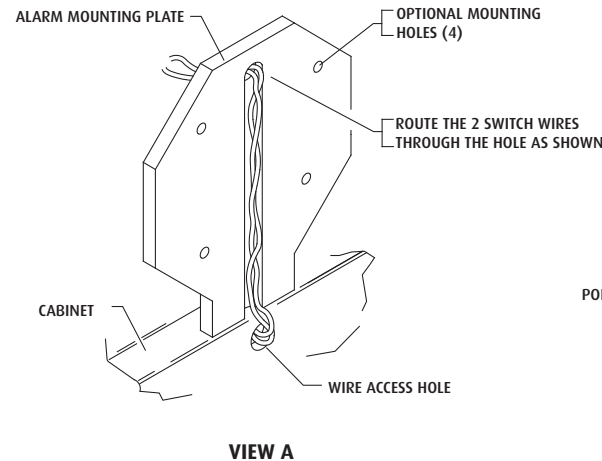

VIEW A

### CLEANING INSTRUCTIONS

Rinse with water to remove abrasive dust and dirt. Wash with soap or mild detergent, using a soft cloth. (Do not scrub or use brushes or abrasives.) Rinse once more, then dry using a soft cloth or chamois. To remove grease or wet paint, rub gently with a cloth wetted thoroughly with naphtha (do not use razor blades or gasoline) then wash and rinse.

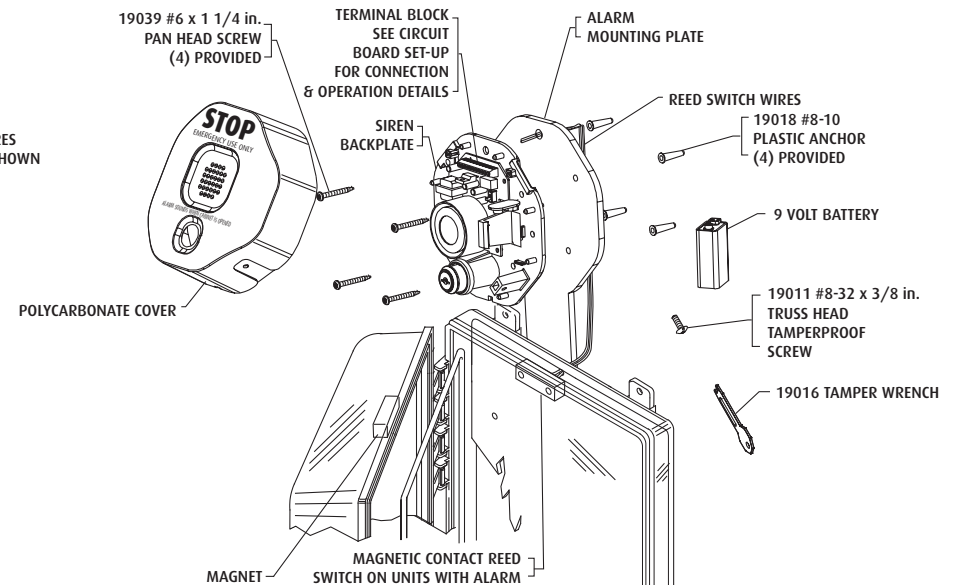
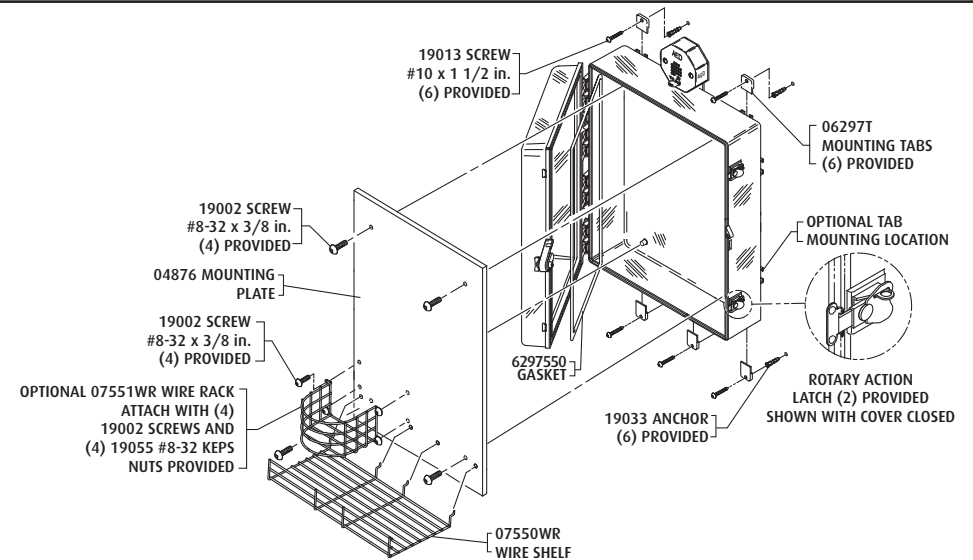

Electronic warranty form at [www.sti-usa.com/wc14](http://www.sti-usa.com/wc14)

## INSTALLATION OF STI-7552, STI-7553 AND STI-7553AED PROTECTIVE CABINET

All specifications and information shown were current as of publication and are subject to change without notice.

7552/53/53AEDIS MAY08



# CIRCUIT BOARD SET-UP

## ALARM CIRCUIT BOARD SET-UP

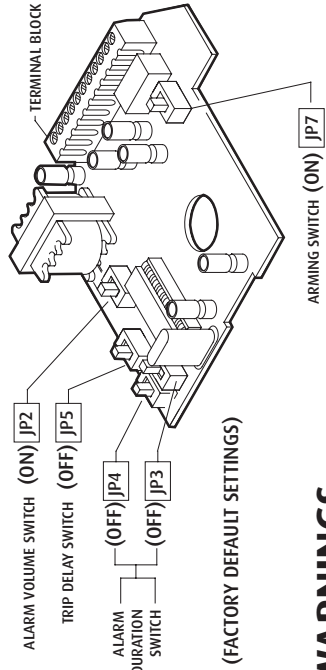

(FACTORY DEFAULT SETTINGS)

## VIEW B

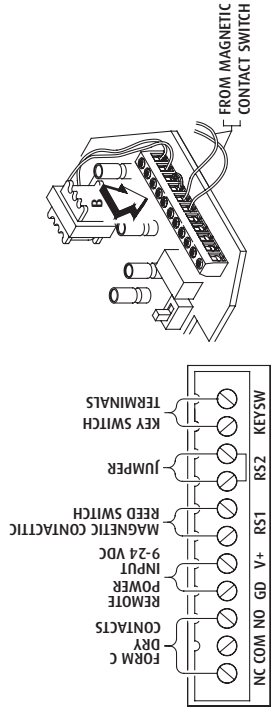

## WARNINGS

All units are recommended for indoor use. Unit must be tested periodically to verify the life of battery. STI recommends you change the 9 Volt battery twice a year. Installer may need to purchase a simple audio-meter, typically available at your local electronics store, to measure the sound in areas where the alarm is expected to be heard during normal noise environment. Results from this test may prove it beneficial to purchase an additional alarm. When purchasing a remote unit (STI-6403) you will need to periodically test the connections to make sure audibles function at a sound level to alert staff. Maximum of three STI-6403 may be used in parallel. All specifications and information shown are current as of publication and subject to change without notice.

## WARRANTY INFORMATION

Lifetime guarantee against breakage of polycarbonate housing (one year on electronic components).

## SPECIFICATIONS

### Alarm Electronics

Power Source	9 VDC Alkaline or 9V-24VDC wired Class II UL Listed transformer
Horn Volume at 1 ft.	95 dB low / 105 dB high
Relay Output	Form C Dry Contacts 0-30 VDC or VAC, 1 Amp
Stand by Current	10uA
Alarm Current	130mA at 95 dB / 200mA at 105 dB

### Polycarbonate Alarm Cover:

Dimensions	5.375" W x 5.375" H x 2 " D (137mm x 137mm x 51mm)
Flammability:	UL94 V-2
Wall Thickness:	0.12 in (3.05mm)

## SWITCH SETTINGS

FEATURE	JP2	JP3	JP4	JP5	JP7
<b>Volume</b> - High (105 dB) at 1 ft.	ON*				
<b>Volume</b> - Low (95 dB) at 1 ft.	OFF				
<b>Duration</b> - 30 Second Alarm		OFF	OFF		
<b>Duration</b> - 180 Second Alarm		OFF	ON		
<b>Duration</b> - Continuous Alarm		ON*	OFF*		
<b>Duration</b> - Annunciator Mode		ON	ON		
<b>Trip</b> - Immediate				OFF*	
<b>Trip</b> - 15 Second Delay				ON	
<b>Arming</b> - Immediate					ON*
<b>Arming</b> - 15 Second Delay					OFF

\*Factory Settings

Note: Slide black lever to desired ON/OFF position as labeled on circuit board.



## Safety Technology International, Inc.

2306 Airport Road • Waterford, Michigan 48327-1209

Phone: 248-673-9898 • Fax: 248-673-1246 • Toll Free: 800-888-4STI • E-mail: [info@sti-usa.com](mailto:info@sti-usa.com) • Web: [www.sti-usa.com](http://www.sti-usa.com)

Europe Branch Office • Unit 49G Pipers Road • Park Farm Industrial Estate • Redditch • Worcestershire • B98 0HU • England

Tel: 44 (0) 1527 520 999 • Fax: 44 (0) 1527 501 999 • Freephone: 0800 085 1678 (UK only) • E-mail: [info@sti-europe.com](mailto:info@sti-europe.com) • Web: [www.sti-europe.com](http://www.sti-europe.com)