

STI POLYCARBONATE PROTECTIVE CABINET



STI-7551AH



PRODUCT OVERVIEW

The A/C or A/C with heat versions of the STI Protective Cabinet allow fire alarm control panels to be protected from extreme temperatures and other conditions that require NEMA 4 protection. The extra large, super tough, see-through polycarbonate enclosure offers protection against vandalism, either accidental or intentional, as well as dirt, dust and grime.

Its size allows the enclosure to house significantly sized electronic devices with space to spare. This NEMA 4 Certified enclosure mounts on the wall enabling units to be protected in their designated location.

HOW IT WORKS

To help maintain the correct range of operating temperatures, the A/C or heating unit cycles as required and a fan runs continuously to sustain a uniform temperature inside the enclosure. The fiberglass A/C or heater contains an integral power supply and built-in condensate removal system. The cost effective, low maintenance, compact and lightweight A/C or A/C with heat unit does not require a compressor, fluorocarbons or filters and is externally mounted to minimize space intrusion.

KEY FEATURES

General Information

- Clear UV-stabilized polycarbonate cover with A/C or A/C and heat.
- The maximum size unit the housing can protect is 16.75 x 21.75 x 5.81 inches (425 x 552 x 147 mm). This allows clearance for proper air circulation.
- Reliable mechanical thermostat.
- Allows fire alarm control panels to be protected from extreme temperatures.
- Three year guarantee against breakage of polycarbonate in normal use (two years on electro mechanical and electronic components).

Design

- Air conditioner/Heater unit is externally mounted to minimize space intrusion.
- Design allows visibility from almost every angle.
- Cost effective, low maintenance, compact and lightweight design.

Construction

- R134A or R-407C earth-friendly refrigerant and RoHS Compliant.

Installation

- Outdoor model operating temperature range from -40 to 131°F (-40 to 55°C).
- Typical working properties of polycarbonate are -40° to 250°F (-40° to 121°C).

Electronics

- Contains an integral power supply and condensate drain port.
- Air conditioning/heating unit cycles as required and a fan runs continuously to sustain a uniform temperature inside the enclosure.

Options

- With air conditioning or air conditioning and heat.
- Key or thumb lock.



For more information, call 1-800-888-4784 (4STI) or visit www.sti-usa.com



**Safety Technology
International, Inc.**

STI Polycarbonate Protective Cabinet

Dimensions and Technical Information

MODELS AVAILABLE

- STI-7550AC** Protective Cabinet with air conditioner - key lock
- STI-7550AH** Protective Cabinet with A/C and heater - key lock
- STI-7551AC** Protective Cabinet with air conditioner - thumb lock
- STI-7551AH** Protective Cabinet with A/C and heater - thumb lock

CONSTRUCTION

Air Conditioner/Heater with Shroud

- Aluminum shroud
- Industrial grade sealed fans
- AC/AH steel construction powder coat finish

Power Requirements:

- 120 VAC
(240 VAC operation available)
- Max startup current: 9.2A
- Max normal current: 3.5A

Output:

- A/C 800 BTU's
- Heat 150 Watts

Cabinet

- Polycarbonate
- Stainless steel latches
- Corrosion resistant thumb lock/key lock
- Mounting plate has a baked enamel finish .08"(2mm) thick steel

NOTES:

- The maximum size unit the housing can protect is 16.75 x 21.75 x 5.81 inches (425 x 552 x 147 mm). This allows clearance for proper air circulation of the AC/heater.
- Heat will keep enclosure above freezing to -20°F.

APPROXIMATE WEIGHT

30 lbs.

24 lbs.

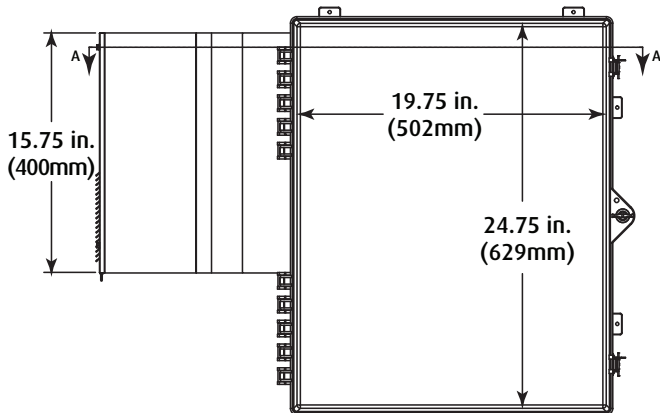
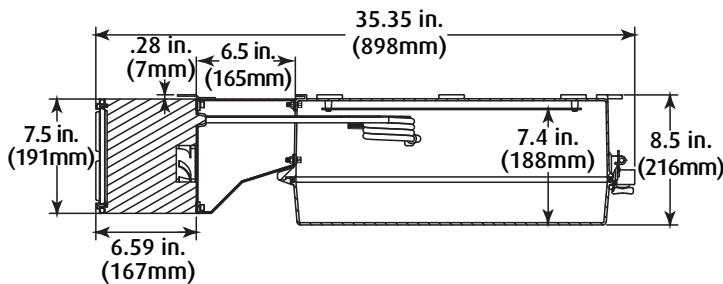

APPROVALS & WARRANTY

TESTING

- CABINET
- Type 4
- UL Listed

AC/HEATER

- Type 12/3R/4
- UL/cUL Listed
- CE

WARRANTY

Three year guarantee against breakage of polycarbonate in normal use (two year on electro mechanical and electronic components).



**Safety Technology
International, Inc.**

2306 Airport Road
Waterford, Michigan
48327, USA

Tel: 248-673-9898
Fax: 248-673-1246
Toll-free: 800-888-4784
info@sti-usa.com
www.sti-usa.com

Unit 49G Pipers Road
Park Farm Industrial Estate
Redditch, Worcestershire
B98 0HU England

Tel: 44 (0) 1527 520 999
Fax: 44 (0) 1527 501 999
www.sti-europe.com