

# STI ACCESS CONTROL HOUSINGS



STI-7515F



STI-7516A

## PRODUCT OVERVIEW

These waterproof, multipurpose sealed housings mount to either a wall or pedestal and are ideal for a variety of access control equipment. Molded of thick polycarbonate material which is backed by a three year guarantee against breakage in normal use.

Housings are available in two depths. Back box "A" provides 4.25 inches of depth and back box "F" provides 2.0 inches of depth.

## HOW THEY WORK

The STI-7515 has four mounting tabs allowing it to be installed on a wall. It can be used as a multipurpose electrical enclosure, connection box, etc. The STI-7516 can be installed to a mounting pedestal and is ideal for a gate entry, call switch or any electrical device configuration.

## KEY FEATURES

### General Information

- Helps solve installation problems for a variety of access control equipment.
- Three year guarantee against breakage of polycarbonate in normal use.

### Design

- STI-7515 has four mounting tabs allowing it to be installed on a wall.
- STI-7516 is designed to be installed on a mounting pedestal and includes adapter plate (SUB-318).

### Construction

- NEMA 4.
- Housings are water resistant to provide added protection for these important devices.

### Installation

- Mounting hardware is included.
- Typical working properties of polycarbonate are -40° to 250°F (-40° to 121°C).

### Options

- Available in two depths.



For more information, call 1-800-888-4784 (4STI) or visit [www.sti-usa.com](http://www.sti-usa.com)



**Safety Technology  
International, Inc.**

# STI Access Control Housings

## Dimensions and Technical Information

### MODELS AVAILABLE

- STI-7515A** Housing, wall mount, "A" back box
- STI-7515F** Housing, wall mount, "F" back box
- STI-7516A** Housing, pedestal mount, adapter plate, "A" back box
- STI-7516F** Housing, pedestal mount, adapter plate, "F" back box

### Accessories

- SUB-318** Adapter plate used for mounting "A" or "F" back box to pedestal

### WARRANTY

Three year guarantee against breakage of polycarbonate in normal use.

### NOTE:

Housings do not include pedestal.  
For information on pedestal, see STI-9779 spec sheet.

The shaded areas represent the mounting tabs (included with STI-7515 only) for wall installation

	H	W	D
STI-7515A	6.46 in.(164mm)	8.44 in.(214mm)	4.12 in.(104mm)
STI-7515F	6.57 in.(166mm)	8.55 in.(217mm)	2 in.(50mm)
STI-7516A			
STI-7516F			

### A MODELS

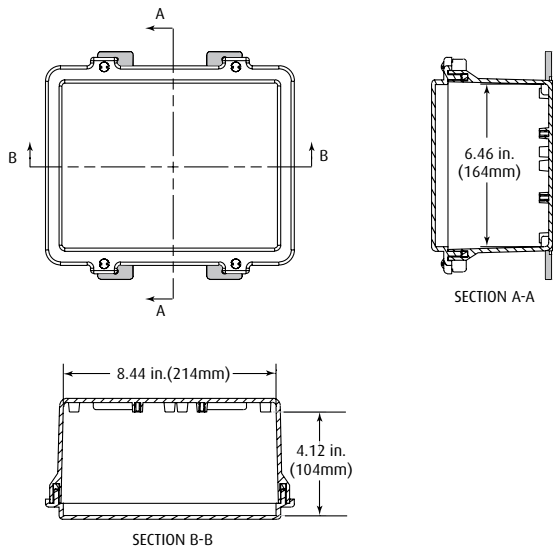

### F MODELS

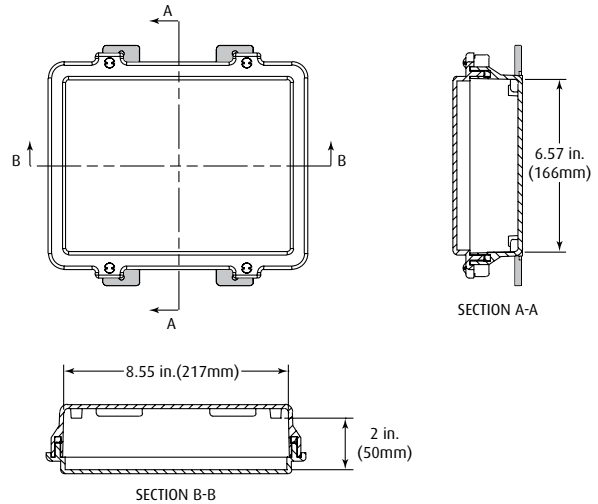

**Safety Technology International, Inc.**

2306 Airport Road  
Waterford, Michigan  
48327, USA

Tel: 248-673-9898  
Fax: 248-673-1246  
Toll-free: 800-888-4784  
info@sti-usa.com  
www.sti-usa.com

Unit 49G Pipers Road  
Park Farm Industrial Estate  
Redditch, Worcestershire  
B98 0HU England

Tel: 44 (0) 1527 520 999  
Fax: 44 (0) 1527 501 999  
www.sti-europe.com