

	30"	36"	42"	48"
DIM A	25	31	37	43

**CUT-OFF INSTRUCTIONS FOR NON-STANDARD DOORS**

1. DRIVE OUT TWO ROLL PINS.
2. REMOVE MOUNTING CAP.
3. COLLAPSE BAR AND TAPE DOWN IN THE AREA OF CUT-OFF.
4. DETERMINE EXTRUSION LENGTH ("B" DIM). (NOTE: 3 19/32" MINIMUM DIMENSION FROM RIVET CENTERLINE TO NEW CUTOFF LENGTH AS SHOWN).
5. MEASURE MOUNTING BAR (NOT PUSH BAR), AND MARK EXTRUSION LENGTH ON TAPE.
6. SAW OFF EXCESS LENGTH, REMOVE TAPE AND DEBURR.
7. LAY MOUNTING CAP OVER MOUNTING BAR (FIG. "C"), AND USE AS A GUIDE TO DRILL TWO 1/8" DIA HOLES.
8. RE-INSTALL MOUNTING CAP INTO MOUNTING BAR AND DRIVE TWO ROLL PINS INTO HOLES.

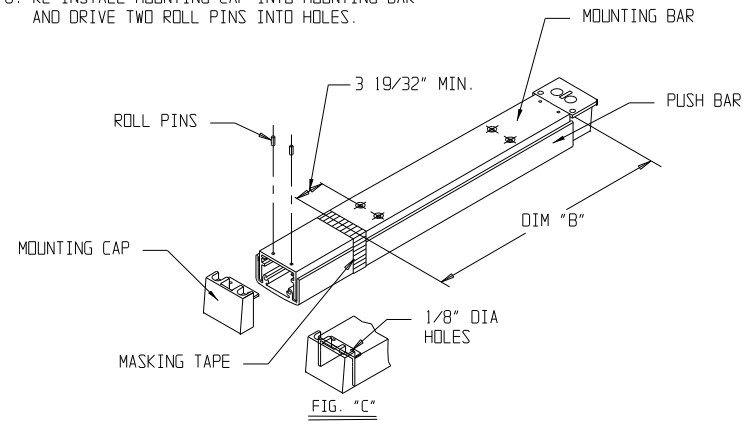

**SEPARATING PUSH BAR AND MOUNTING BAR PROCEDURE**

1. REMOVE BOTH END CAPS. THE RETAINER IS ATTACHED TO THE NOSE END CAP.
2. SLIDE PUSH BAR TOWARD HINGE SIDE OF DOOR.
3. CONTINUE TO SLIDE THE PUSH BAR PAST THE PIVOT PLATE THAT RIDES IN PUSH BAR TRACK.
4. SLIDE PUSH BAR IN OPPOSITE DIRECTION KEEPING PIVOT PLATE OUT OF TRACK UNTIL PUSH BAR IS FREE OF MOUNTING PLATE.

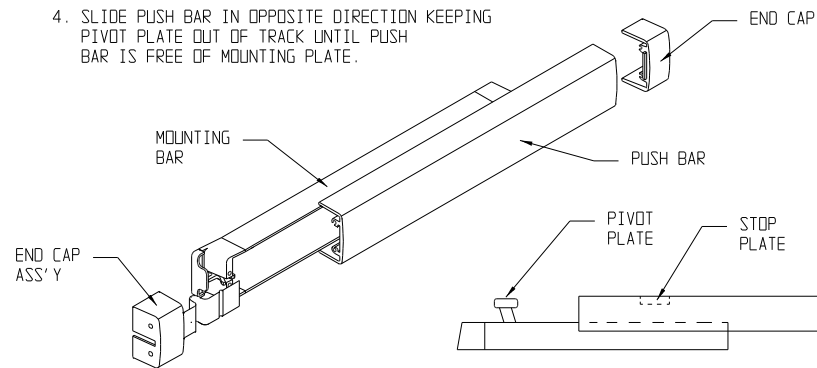

**INSTALLING PUSH BAR TO MOUNTING BAR**

1. WITH PUSH BAR IN HAND AND MOUNTING BAR ATTACHED TO DOOR, FIND STOP PLATE, STAKED INTO PUSH BAR. (THIS PLATE IS ON THE LATCH END OF ASSEMBLED UNIT). SLIDE THE PIVOT PLATE NEAREST HINGE INTO TRACK OF PUSH BAR UNTIL SECOND PIVOT PLATE IS EXPOSED. INSERT SECOND PIVOT PLATE INTO TRACK ON PUSH BAR AND SLIDE IN OPPOSITE DIRECTION UNTIL PUSH BAR AND MOUNTING BAR ALIGN.

**PREPARATION**

NOTE: THESE DIMENSIONS AND TEMPLATES ASSUMES A DOOR THICKNESS OF 1 3/4". FOR DOORS OF OTHER THICKNESS, CONSULT FACTORY.

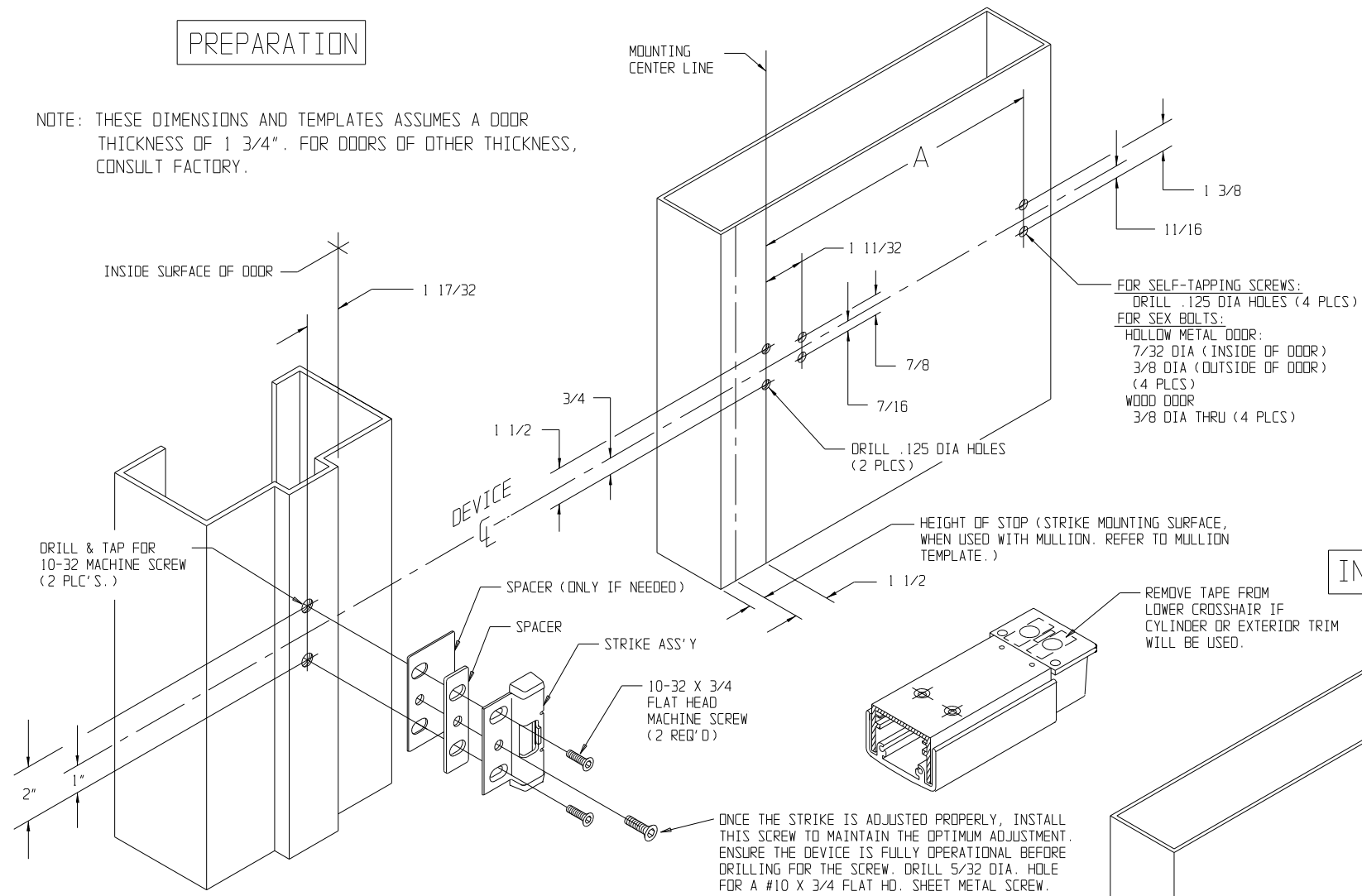

METRIC EQUIVALENTS			
INCHES	MM	INCHES	MM
1/8	3,17	1 1/4	31,75
7/32	5,56	1 11/32	34,14
1/4	6,35	1 3/8	34,93
5/16	7,92	1 1/2	38,10
3/8	9,53	1 17/32	38,89
13/32	10,31	1 3/4	44,45
7/16	11,12	2	50,80
29/64	11,51	3 19/32	91,29
5/8	15,88	25	635,00
11/16	17,45	30	762,00
3/4	19,05	31	787,40
.813	20,65	36	914,40
7/8	22,23	37	939,80
29/32	23,03	42	1066,80
1	25,40	43	1092,20
1 3/16	30,15	48	1219,20

**INSTALLATION**

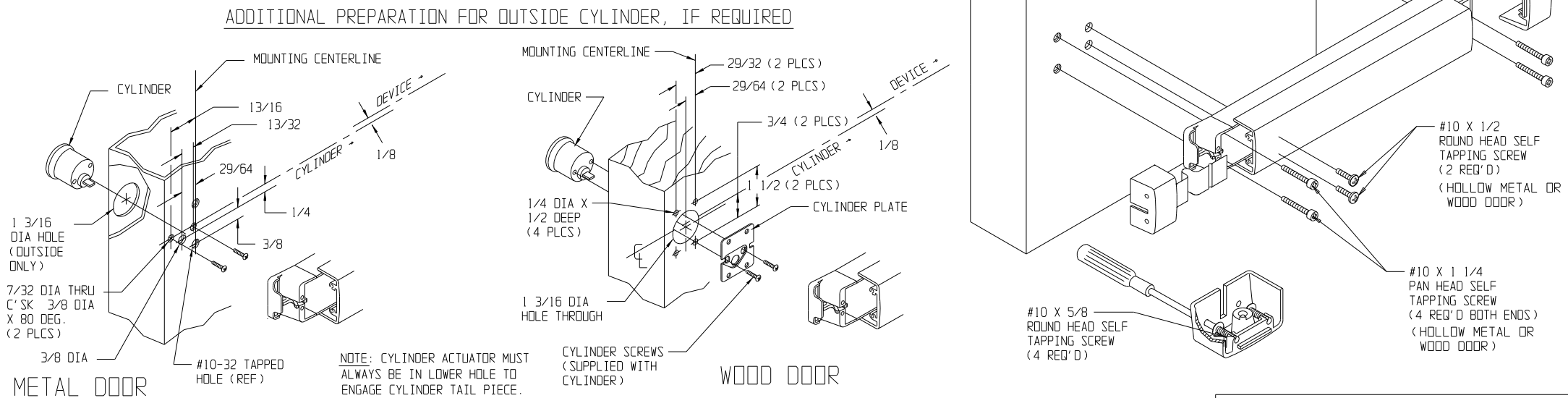

PRODUCT MUST BE INSTALLED ACCORDING TO ALL APPLICABLE BUILDING AND LIFE SAFETY CODES

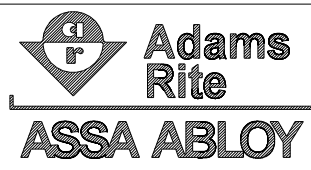

www.adamsrite.com  
Phone: 800-626-7590  
800-872-3267  
Fax: 866-582-4641  
800-232-7329

**80-0180-85**  
Rev. M

**3700 FIRE RATED EXIT DEVICE FOR WOOD OR HOLLOW METAL DOOR**  
Ecn 11955B Date: 06/25/12

**INSTALLATION INSTRUCTIONS**  
Page 1 of 1 Appvd: MP Date: 07/06/12