

REVISIONS

REV.	DESCRIPTION	DATE	APPROVED
C	Exchange 2620-440 Nut With 2620-320 Center lock Nut	4/5/2011	DC
D	Add (2) 2615-674 Car Bolt, (2) 2600-147 Spacer, (2) 1602-240 Brace, (2) 2620-021 Washer, (4) 2620-047 L Wshr, (2) 2615-052 Hex Bolt 3/8-16 x 1", (4) 2620-405 Nut, Change 2600-089 30Belt to 2600-690 29Belt	9/15/2011	DC

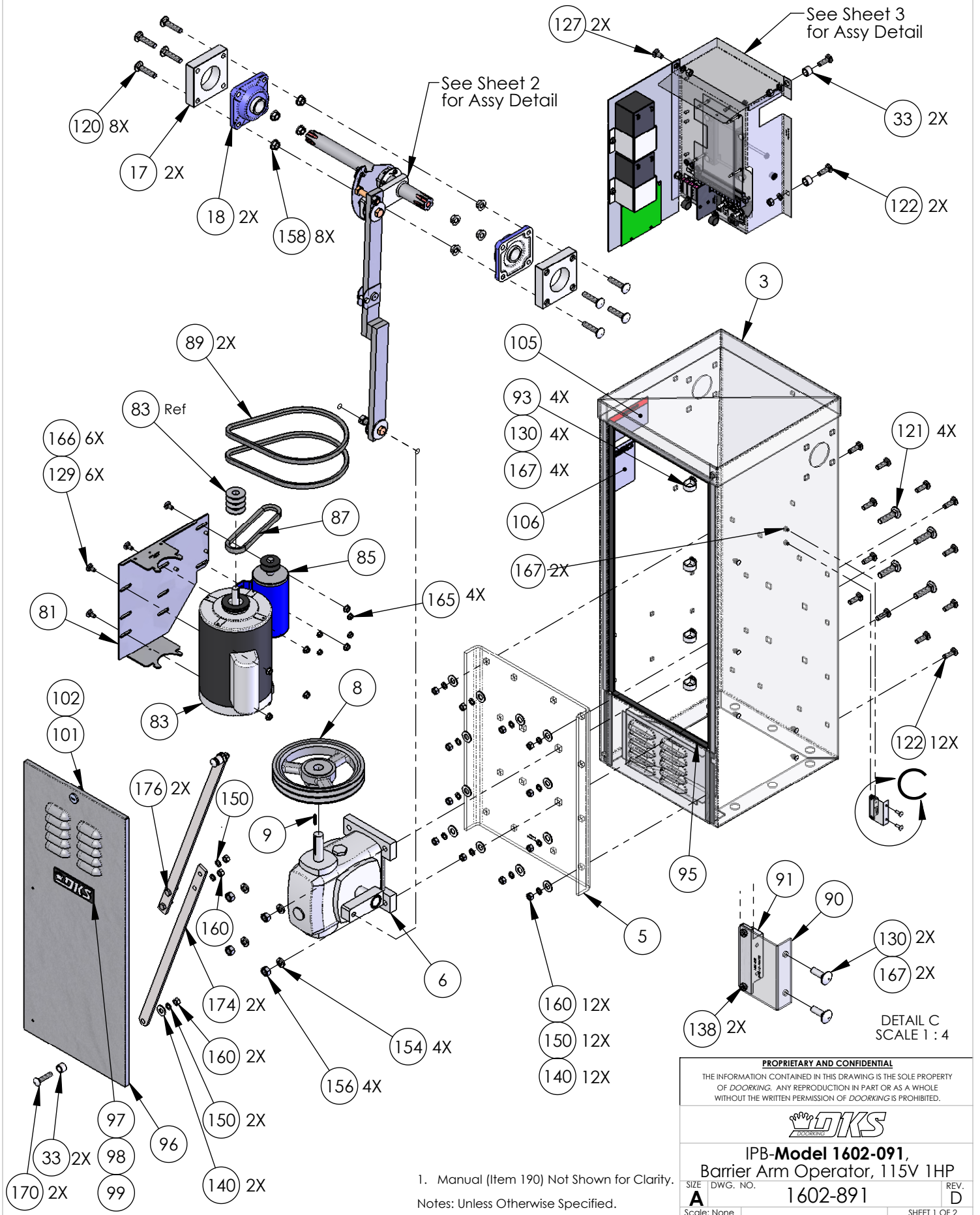

1. Manual (Item 190) Not Shown for Clarity.
 Notes: Unless Otherwise Specified.

PROPRIETARY AND CONFIDENTIAL
 THE INFORMATION CONTAINED IN THIS DRAWING IS THE SOLE PROPERTY OF DOORKING. ANY REPRODUCTION IN PART OR AS A WHOLE WITHOUT THE WRITTEN PERMISSION OF DOORKING IS PROHIBITED.

IPB-Model 1602-091,
Barrier Arm Operator, 115V 1HP

SIZE **A** DWG. NO. **1602-891** REV. **D**

Scale: None SHEET 1 OF 2

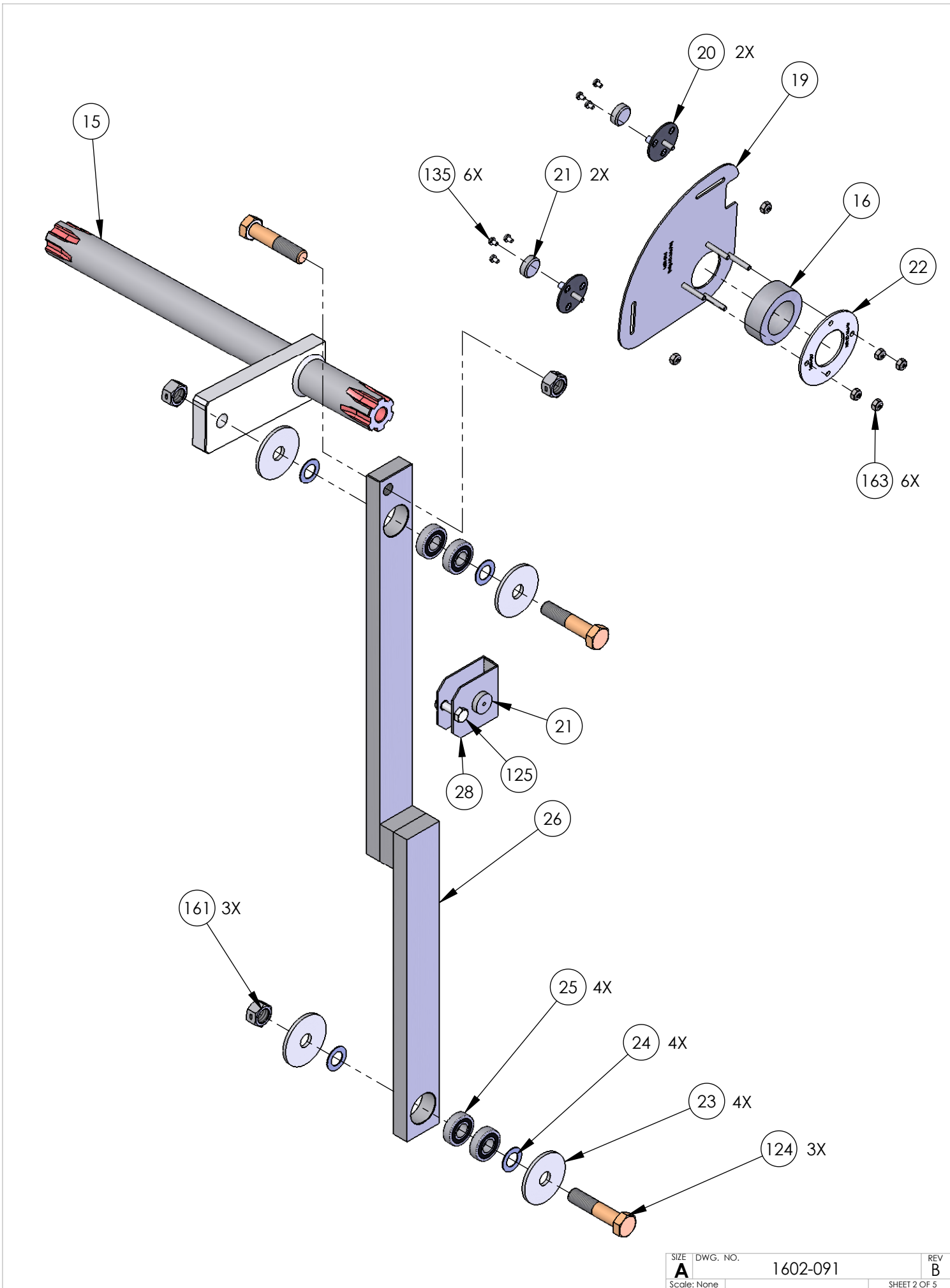

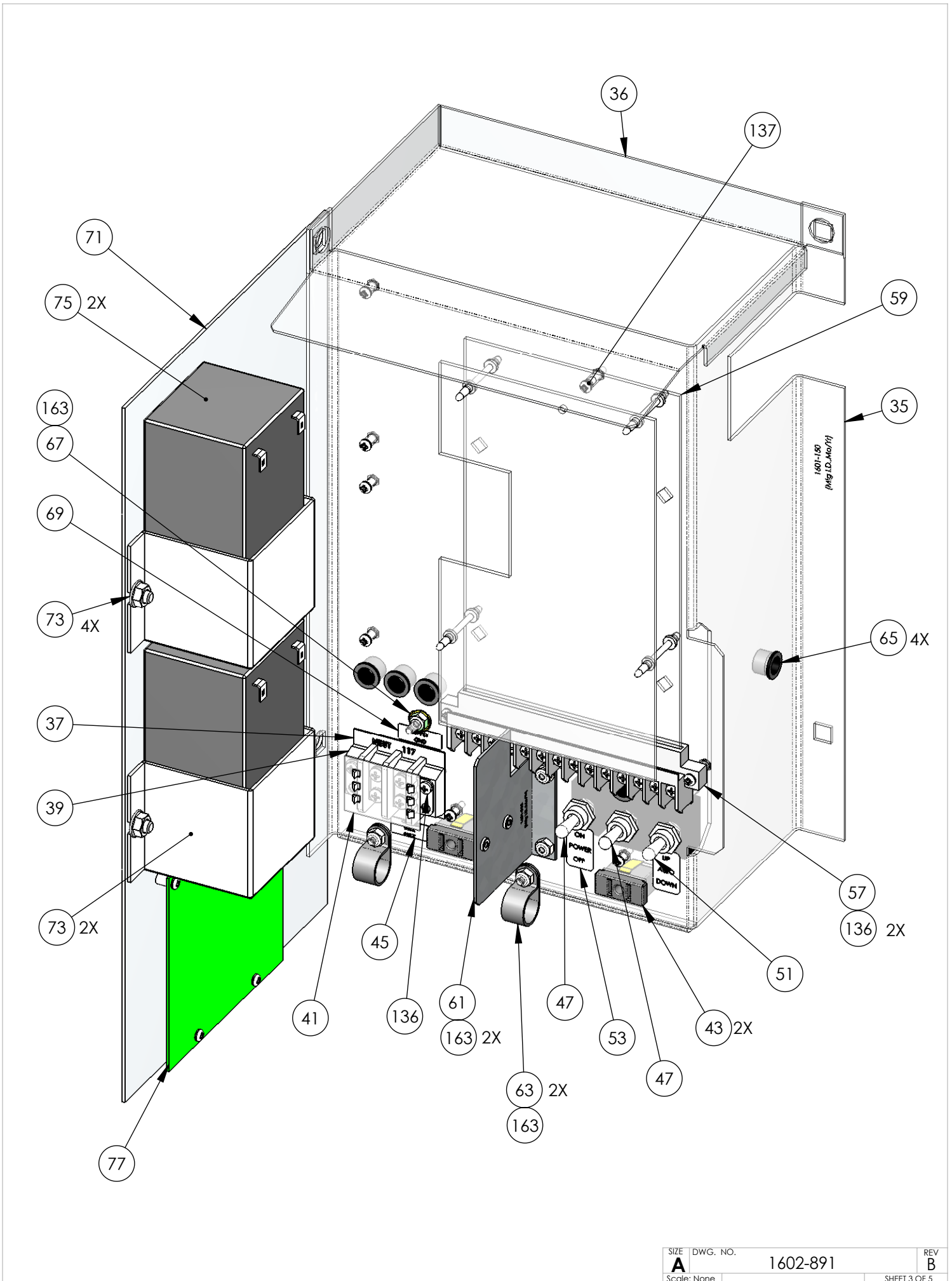

ITEM	NUMBER	QTY	DESCRIPTION
1	1602-891	1 EA	IPB Operator
3	1602-200	1 EA	Housing 1602
5	1602-016	1 EA	Mount Plate Gearbox
6	2600-718	1 EA	Gearbox Barrier Arm 1602
8	1602-050	1 EA	Pulley Dual 8"OD 7/8"ID
9	1601-019	1 EA	Keyway 3/16"x3/16"x1"
10	2616-094	1 EA	Set Screw 5/16-18 x1/4
15	1601-222	1 EA	Shaft Assembly 1601 Splined
16	2600-061	2 EA	Collar 2"OD x 1 1/4"ID x 5/8"L
17	1200-011	2 EA	Spacer Pillowblock Bearing
18	1200-010	2 EA	Hinge Bearing
19	1601-016	1 EA	Mount Plate Magnet
20	1601-044	2 EA	Holder - Magnet
21	2600-817	2 EA	Magnet
22	1601-017	1 EA	Collar "Sandwich" Plate
23	2620-131	4 EA	Washer 1 7/8"ODx1/2"ID 1/8 T
24	1601-185	4 EA	Washer Race .515"IDx.875"OD CH
25	1601-060	4 EA	Bearing-Sealed 1/2ID x 1 1/8OD
26	1602-031	1 EA	Connecting Link
28	1601-250	1 EA	Bracket Magnet Holder
33	2600-147	4 EA	Spacer Steel .75"ODx.53IDx.56L
35	1601-150	1 EA	Mount Plate - PC Board Bottom
36	1601-152	1 EA	Mount Plate - PC Board Top
37	2600-410	1 EA	Marker Strip
39	2600-414	1 EA	Terminal Block-2 Position
41	3129-002	1 EA	Terminal Block Cover 2 Position
43	1200-028	2 EA	Outlet Snap-In
45	2599-014	1 EA	Decal Copper Wire Only
49	1601-041	1 EA	Switch Toggle SPST 2POS
51	1601-040	1 EA	Switch Toggle ON-OFF Momentary
53	2599-012	1 EA	Decal 1601 Switch
57	1601-007	1 EA	Terminal 14 Pin
59	1601-010	1 EA	PCB Parking Gate
61	1601-055	1 EA	Divider - High/Low Voltage
63	2600-619	2 EA	Wire Cilp
65	2600-820	5 EA	Bushing 1/2
67	2600-439	1 EA	Washer Cup - Brass
69	2599-006	1 EA	Decal SUPPLY GND
71	1601-245	1 EA	Mount Plate 1601 BBU
73	2600-676	2 EA	Battery Tray 1601
75	1801-009	2 EA	Battery 12V 3.4 AmpHour
77	2340-010	1 EA	PCB Battery Backup
79	1804-029	3 EA	Mount Wire Tie
81	1602-037	1 EA	Motor Base 1 HP
83	2601-164	1 EA	Motor Assy 1HP 3V Pulley Crank
85	2600-197	1 EA	Motor 24VDC For BB
87	2600-688	1 EA	Belt - 17" 4L170 Cogged
89	2600-690	2 EA	Belt 29"
90	1601-252	1 EA	Bracket Sensor 1601 Batt Back
91	1601-253	1 EA	Switch Magnetic Sensor
93	2600-639	4 EA	Wire Clamp-1"
95	4001-018	6 FT	Weather Stripping
96	1602-075	1 EA	Door
97	1897-052	2 EA	Gasket
98	2600-732	1 EA	Nameplate Plastic DKS Big
99	2802-040	2 EA	Washer Push on Clamp
100	2599-008	1 EA	Label Patent

ITEM	NUMBER	QTY	DESCRIPTION
101	4001-035	1 EA	Lock Key 16120
102	1702-503	1 EA	Cam 1 1/4
105	2599-035	1 EA	Label 1601 Warning
106	2599-199	1 EA	Label Universal
107	2599-039	1 EA	Label 1601 Warning
110	1601-008	1 EA	Wire Set 1601/1602
111	2340-164	1 EA	Wire Set BB 6100,6300,9150
112	1804-031	6 EA	Tie Wrap 4"
113	2600-749	2 EA	Wire Connector STA-KON RC6
114	2340-166	1 EA	Wire Set BB 1601
115	2340-065	1 EA	Manual
120	2615-690	8 EA	Bolt Carriage 7/16-14 x2 WhtSS
121	2615-694	4 EA	Bolt Carriage 1/2-13 x 2 White
122	2615-669	14 EA	Bolt Carriage SS 3/8-16x11/4"
123	2615-673	4 EA	Bolt Carriage SS 3/8-16x2 1/4"White
124	2615-184	3 EA	Bolt Hex Head 1/2-13x2 1/4 GR8
125	1601-250	1 EA	Bolt Hex Head 1/4-20x1"
127	2615-667	4 EA	BoltCarr SS 3/8"x16x3/4"Paint
129	2615-662	8 EA	BoltCarr SS 5/16"x18x5/8"Paint
130	2615-645	11 EA	Bolt Carr SS 10-32x5/8"Painted
135	2616-006	6 EA	Screw Phillips Head 6-32x3/16
136	2616-003	4 EA	Screw Phillips Head 6-32x3/4SS
137	2616-002	1 EA	Screw Phillips Head 6-32 x 1/2
138	2616-001	2 EA	Screw Phillips Head 6-32 x 3/8
139	2616-000	4 EA	Screw Phillips Head 6-32 x 1/4
140	2620-021	14 EA	Washer 1/2 " SAE
141	2802-003	2 EA	Washer #8 SAE
142	2620-029	2 EA	Washer 3/8" USS
150	2620-047	22 EA	Lockwasher 3/8"
154	2620-050	4 EA	Lockwasher 1/2"
156	2620-420	4 EA	Nut Hex 1/2-13
158	2620-413	8 EA	Nut Hex Flange Lock 7/16-14
160	2620-405	22 EA	Nut Hex 3/8-16
161	2620-320	3 EA	Nut Center Lock 1/2-13
162	2620-401	2 EA	Nut Hex 8-32
163	2902-004	9 EA	Nut Nylon Lock 8-32
164	2620-340	4 EA	Nut Center Lock 1/4-20
165	2620-409	4 EA	Nut Hex Flange Lock 1/4-20
166	2620-411	8 EA	Nut Hex Flange Lock 5/16-18
167	2902-006	14 EA	Nut Nylon Lock 10-32
170	2615-674	2 EA	Carriage Bolt 3/8-16 x 1 1/4
174	1602-240	2 EA	Brace Diagonal
176	2615-052	2 EA	Bolt 3/8-16 x 1 Hex
180	2599-220	1 EA	Label Caution Remove Rod
185	2599-039	1 EA	Label Electrical Hazard
190	1601-065	1 EA	Manual Installation