



SECURITY DOOR CONTROLS

3580 Willow Lane, Westlake Village, CA 91361-4921 • (805) 494-0622 • Fax: (805) 494-8861
www.sdcsecurity.com • E-mail: service@sdsecurity.com

INSTALLATION INSTRUCTIONS SHEAR LOCKING MAGNET 1561S MAX. HOLDING FORCE 2000 LBS.

REFER TO THE PROPER TEMPLATE ACCORDING TO THE TYPE OF DOOR AND FRAME APPLICATION.

READ THESE INSTRUCTIONS AND STUDY THE TEMPLATE THOROUGHLY BEFORE BEGINNING THE INSTALLATION.

IMPORTANT NOTES:

Although electromagnetic shear locks provide the utmost in aesthetics for fail-safe applications, they are less forgiving than electric bolt locks and direct pull magnetic locks where alignment problems exist. Therefore, great care must be taken during preparation and installation of the frame, door hardware and the shear locking magnet to attain proper alignment and insure positive lock operation.

Unbalanced air conditioning (stack pressure) can hinder door alignment and must be corrected to help insure positive locking.

Use only the highest quality door closer.

Door latching problems must be corrected prior to installation.

INSTALLATION

1. Make sure the clearance between the door top rail and frame header is $\frac{1}{8}$ ". Make adjustments to the door as required.
2. Adjust single acting door and door closer to insure the door settles immediately and is fully closed and at rest against the stop allowing for mutes, smoke seals or weather stripping where applicable.
3. Locate the vertical centerline of the locking magnet and armature as close as possible to the leading door edge.
4. Mark the door per the template.
5. Before determining the frame header, centerline single acting doors must be fully closed and at rest against the stop allowing for mutes, smoke or weather stripping where applicable.
6. Mark the frame header per Fig 1.
7. Prepare the door and frame per Fig 1.
8. An auto relock time delay (built-in with 1561S) is recommended for all installations to delay relocking 1 to 6 seconds after initial door closure. This will help insure the door is fully closed and at rest to obtain optimum alignment before the locking magnet is energized. Consult Figure 2.

With the power off make all wire connections to a properly fused power source.

9. Install the locking magnet and armature with the auto relock switch assembly towards the leading edge of the door.

The 1561S timer adjustment can be made after the locking magnet is installed through the small hole in the face of the magnet. Using a small flat blade screwdriver, turn clockwise to increase time, counter clockwise to decrease time.

10. For proper operation the armature must be adjusted upward as close as possible and parallel to the locking magnet without interfering with opening and closing of the door. Proper operation cannot be expected with more than 1/8" clearance between the armature and the locking magnet. If you find the clearance to be more than 1/8", shim the assembly with the shims provided.
11. With the door closed, turn the lock power on. Check the lateral alignment. The armature shear stops should be centered between each pair of magnet shear stops.
12. If the clearance between the shear stops is sufficient, open and close the door a few times to insure the locking magnet will lock and unlock positively.
13. Adjust the auto relock switch magnet to avoid early activation and help insure positive locking on door closure. Adjust inward to delay locking magnet activation. Do not adjust higher than the armature rest position.
14. If the shear stops are too close or binding, double check the templating and door alignment, and make corrections as required.
15. If positive locking cannot be attained due to misalignment after the previous adjustments, the armature shear stops can be reversed with the wide clearance shear stops. Consult Fig. 3.

CAUTION: The use of armature offset shear stops may correct misalignment but should not be used when proper door latching is inhibited.

16. Repeat Steps 10 through 14 as necessary following shear stop replacement.
17. Cycle the door and locking magnet several times after the completion of installation.

MODEL #	LOCK DIMENSION			HOLDING FORCE	POWER CONSUMPTION		MODEL #	ARMATURE DIMENSION		
	L	W	D		12VDC	24VDC		L	W	D
1561S	8"	1 3/4"	1 3/4"	2000	650mA	350mA	SURFACE	8"	1 3/4"	1"

FIGURE 1

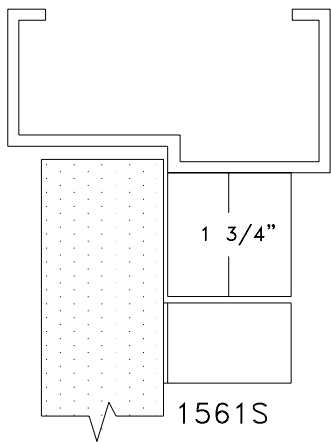

FIG. A LOCK HOUSING

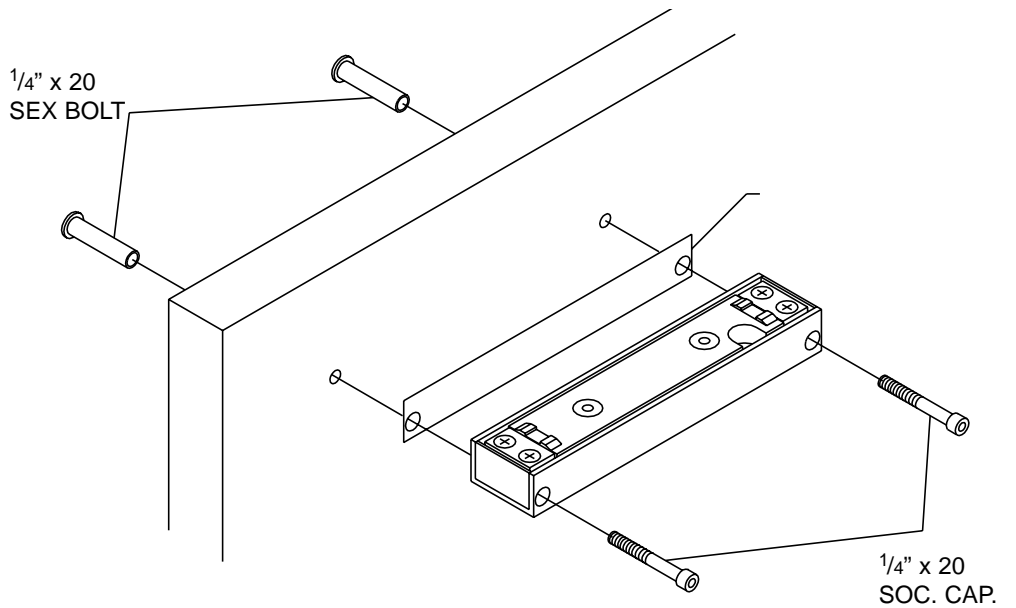

FIG. B INSTALLATION OF ARMATURE ASSEMBLY

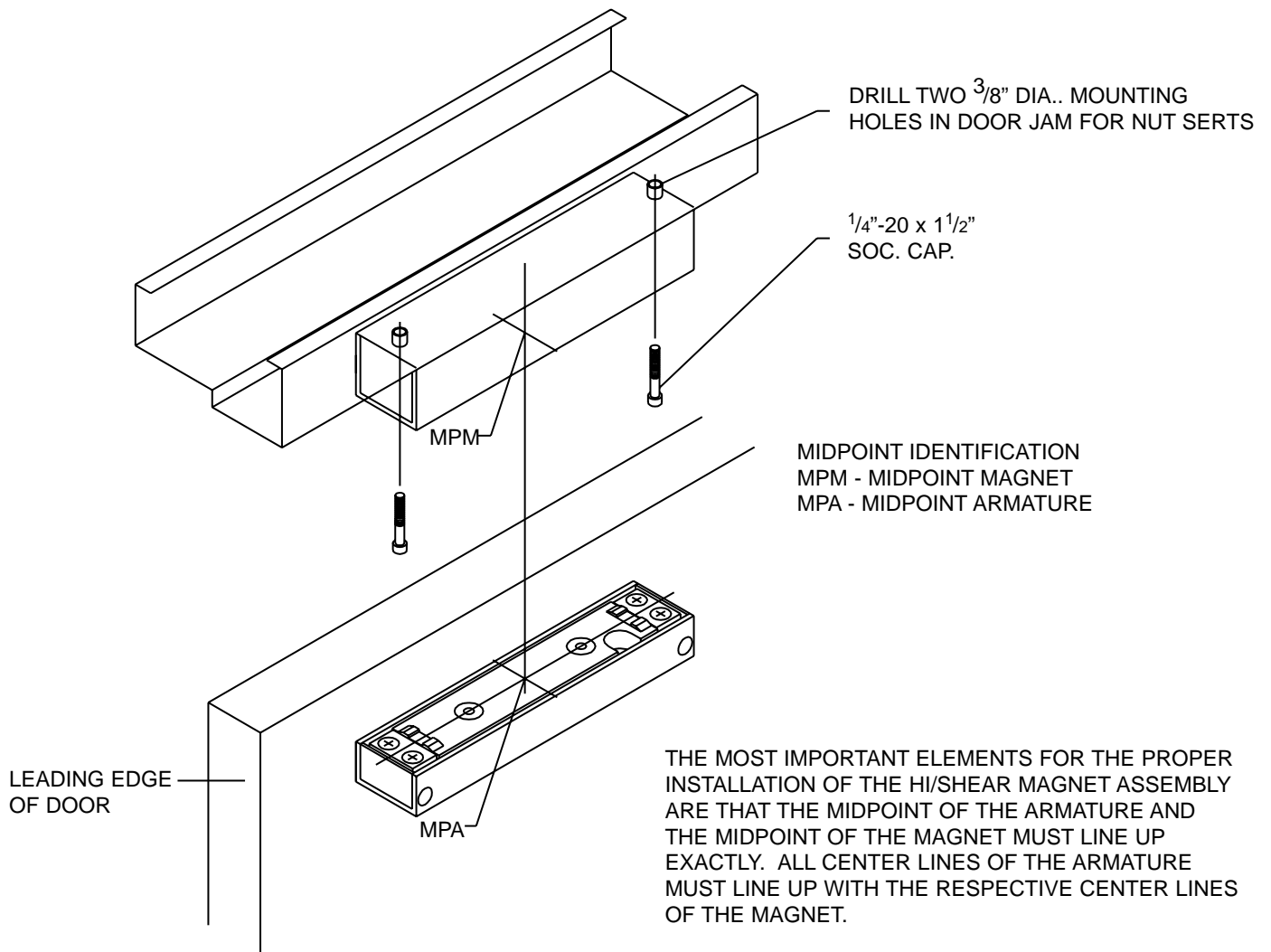
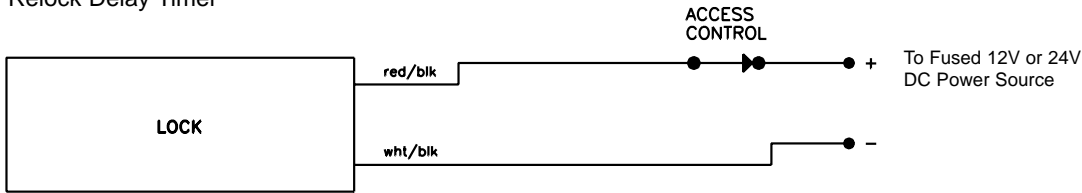

FIG. C PROPER INSTALLATION ALIGNMENT

FIGURE 2

Model 1561S - With built in
Auto Relock Switch Auto
Relock Delay Timer



DPS OPTION
YEL = N/O
GREY = COM
ORG = N/C

BAS OPTION
WHT = N/O
BLK = COM
RED = N/C

FIGURE 3

Please note the drawing in Fig. A. It shows two different alignments off center of the shear tab.

For normal single acting door alignment see Fig. B.

For double acting doors see Fig. F.

For slightly warped single acting doors see Fig. D.

This also works well for quick release, when switch bars are used.

The offset shear tab cannot be used on shear locks with bond sensors. Fig. E & G.

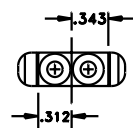

FIG. A
006-001-03A



FIG. C
006-001-03A
Offset shear tabs
ARMATURE TOP VIEW

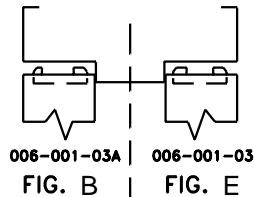

FIG. B

FIG. E

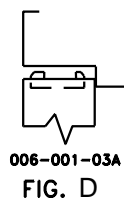

FIG. D

ARMATURE SHEAR TAB
INSTALLATION



FIG. F
006-001-03
Even shear tabs
ARMATURE TOP VIEW
For locks with bond sensor

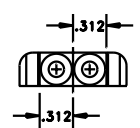

FIG. G
006-001-03

MAINTENANCE INSTRUCTIONS

The electromagnet and the armature should be handled carefully. Any damage to the surface such as paint, burrs, dirt and rust may hinder bonding of the surface and reduce holding power.

IF THE SURFACE PLATING BECOMES DAMAGED

1. Do not touch lock face with your hands.
2. Use a soft clean dry cloth or abrasive cloth (i.e., Scotch-Brite by 3M) to clean the lock face. Do not use sand paper.
3. A rust inhibitor, such as M1 manufactured by Starret, or LPS3 manufactured by LPS Laboratories (available at most hardware stores) can then be applied to the lock face.
4. Apply a coat of rust inhibitor to the armature face also.



SECURITY DOOR CONTROLS

3580 Willow Lane, Westlake Village, CA 91361-4921 • (805) 494-0622 • Fax: (805) 494-8861
www.sdcsecurity.com • E-mail: service@sdsecurity.com

INSTALLATION INSTRUCTIONS SHEAR LOCKING MAGNET 1561TJ MAX. HOLDING FORCE 2000 LBS.

REFER TO THE PROPER TEMPLATE ACCORDING TO THE TYPE OF DOOR AND FRAME APPLICATION.

READ THESE INSTRUCTIONS AND STUDY THE TEMPLATE THOROUGHLY BEFORE BEGINNING THE INSTALLATION.

IMPORTANT NOTES:

Although electromagnetic shear locks provide the utmost in aesthetics for fail-safe applications, they are less forgiving than electric bolt locks and direct pull magnetic locks where alignment problems exist. Therefore, great care must be taken during preparation and installation of the frame, door hardware and the shear locking magnet to attain proper alignment and insure positive lock operation.

Unbalanced air conditioning (stack pressure) can hinder door alignment and must be corrected to help insure positive locking.

Use only the highest quality door closer.

Door latching problems must be corrected prior to installation.

INSTALLATION

1. Make sure the clearance between the door top rail and frame header is $\frac{1}{8}$ ". Make adjustments to the door as required.
2. Adjust single acting door and door closer to insure the door settles immediately and is fully closed and at rest against the stop allowing for mutes, smoke seals or weather stripping where applicable.
3. Locate the vertical centerline of the locking magnet and armature as close as possible to the leading door edge.
4. Mark the door per the template.
5. Before determining the frame header, centerline single acting doors must be fully closed and at rest against the stop allowing for mutes, smoke or weather stripping where applicable.
6. Mark the frame header per Fig 1.
7. Prepare the door and frame per Fig 1.
8. An auto relock time delay (built-in with 1561TJ) is recommended for all installations to delay relocking 1 to 6 seconds after initial door closure. This will help insure the door is fully closed and at rest to obtain optimum alignment before the locking magnet is energized. Consult Figure 2.

With the power off make all wire connections to a properly fused power source.

- Install the locking magnet and armature with the auto relock switch assembly towards the leading edge of the door.

The 1561TJ timer adjustment can be made after the locking magnet is installed through the small hole in the face of the magnet. Using a small flat blade screwdriver, turn clockwise to increase time, counter clockwise to decrease time.

- For proper operation the armature must be adjusted upward as close as possible and parallel to the locking magnet without interfering with opening and closing of the door. Proper operation cannot be expected with more than $\frac{1}{8}$ " clearance between the armature and the locking magnet. If you find the clearance to be more than $\frac{1}{8}$ ", shim the assembly with the shims provided.
- With the door closed, turn the lock power on. Check the lateral alignment. The armature shear stops should be centered between each pair of magnet shear stops.
- If the clearance between the shear stops is sufficient, open and close the door a few times to insure the locking magnet will lock and unlock positively.
- Adjust the auto relock switch magnet to avoid early activation and help insure positive locking on door closure. Adjust inward to delay locking magnet activation. Do not adjust higher than the armature rest position.
- If the shear stops are too close or binding, double check the templating and door alignment, and make corrections as required.
- If positive locking cannot be attained due to misalignment after the previous adjustments, the armature shear stops can be reversed with the wide clearance shear stops. Consult Fig. 3.

CAUTION: The use of armature offset shear stops may correct misalignment but should not be used when proper door latching is inhibited.

- Repeat Steps 10 through 14 as necessary following shear stop replacement.
- Cycle the door and locking magnet several times after the completion of installation.

MODEL #	LOCK DIMENSION			HOLDING FORCE	POWER CONSUMPTION		MODEL #	ARMATURE DIMENSION		
	L	W	D		12VDC	24VDC		L	W	D
1561TJ	8"	1 ³ / ₄ "	1 ³ / ₄ "	2000	650mA	350mA	SURFACE	8"	1 ³ / ₄ "	1"

FIGURE 1

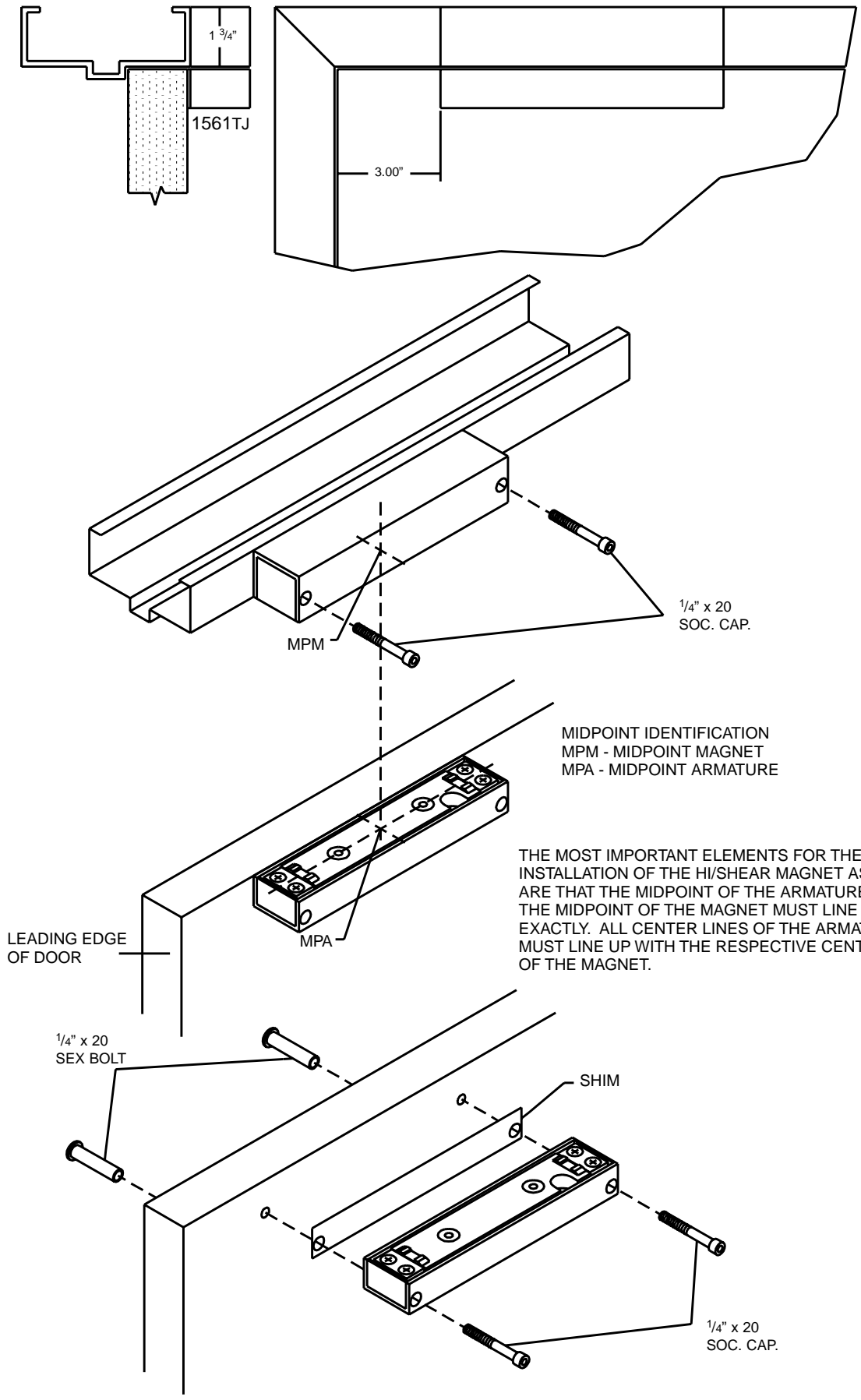

MIDPOINT IDENTIFICATION
 MPM - MIDPOINT MAGNET
 MPA - MIDPOINT ARMATURE

THE MOST IMPORTANT ELEMENTS FOR THE PROPER
 INSTALLATION OF THE HI/SHEAR MAGNET ASSEMBLY
 ARE THAT THE MIDPOINT OF THE ARMATURE, AND
 THE MIDPOINT OF THE MAGNET MUST LINE UP
 EXACTLY. ALL CENTER LINES OF THE ARMATURE
 MUST LINE UP WITH THE RESPECTIVE CENTER LINES
 OF THE MAGNET.

INSTALLATION OF
 ARMATURE ASSEMBLY

FIGURE 2

Model 1561TJ - With built in Auto Relock Switch Auto Relock Delay Timer

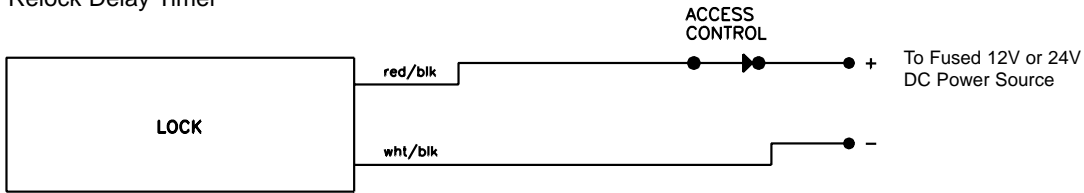

DPS OPTION
 YEL = N/O
 GREY = COM
 ORG = N/C

BAS OPTION
 WHT = N/O
 BLK = COM
 RED = N/C

FIGURE 3

Please note the drawing in Fig. A. It shows two different alignments off center of the shear tab.

For normal single acting door alignment see Fig. B.

For double acting doors see Fig. F.

For slightly warped single acting doors see Fig. D.

This also works well for quick release, when switch bars are used.

The offset shear tab cannot be used on shear locks with bond sensors. Fig. E & G.

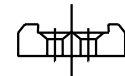
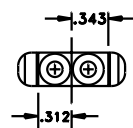

FIG. A
006-001-03A

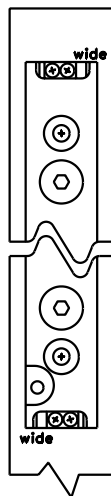
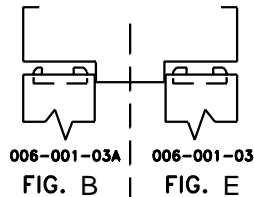

FIG. C
006-001-03A
Offset shear tabs
ARMATURE TOP VIEW



006-001-03A | 006-001-03
FIG. B | **FIG. E**
 006-001-03A
FIG. D

ARMATURE SHEAR TAB
INSTALLATION



FIG. F
006-001-03
Even shear tabs
ARMATURE TOP VIEW
For locks with bond sensor

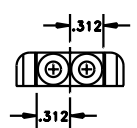

FIG. G
006-001-03

MAINTENANCE INSTRUCTIONS

The electromagnet and the armature should be handled carefully. Any damage to the surface such as paint, burrs, dirt and rust may hinder bonding of the surface and reduce holding power.

IF THE SURFACE PLATING BECOMES DAMAGED

1. Do not touch lock face with your hands.
2. Use a soft clean dry cloth or abrasive cloth (i.e., Scotch-Brite by 3M) to clean the lock face. Do not use sand paper.
3. A rust inhibitor, such as M1 manufactured by Starret, or LPS3 manufactured by LPS Laboratories (available at most hardware stores) can then be applied to the lock face.
4. Apply a coat of rust inhibitor to the armature face also.