

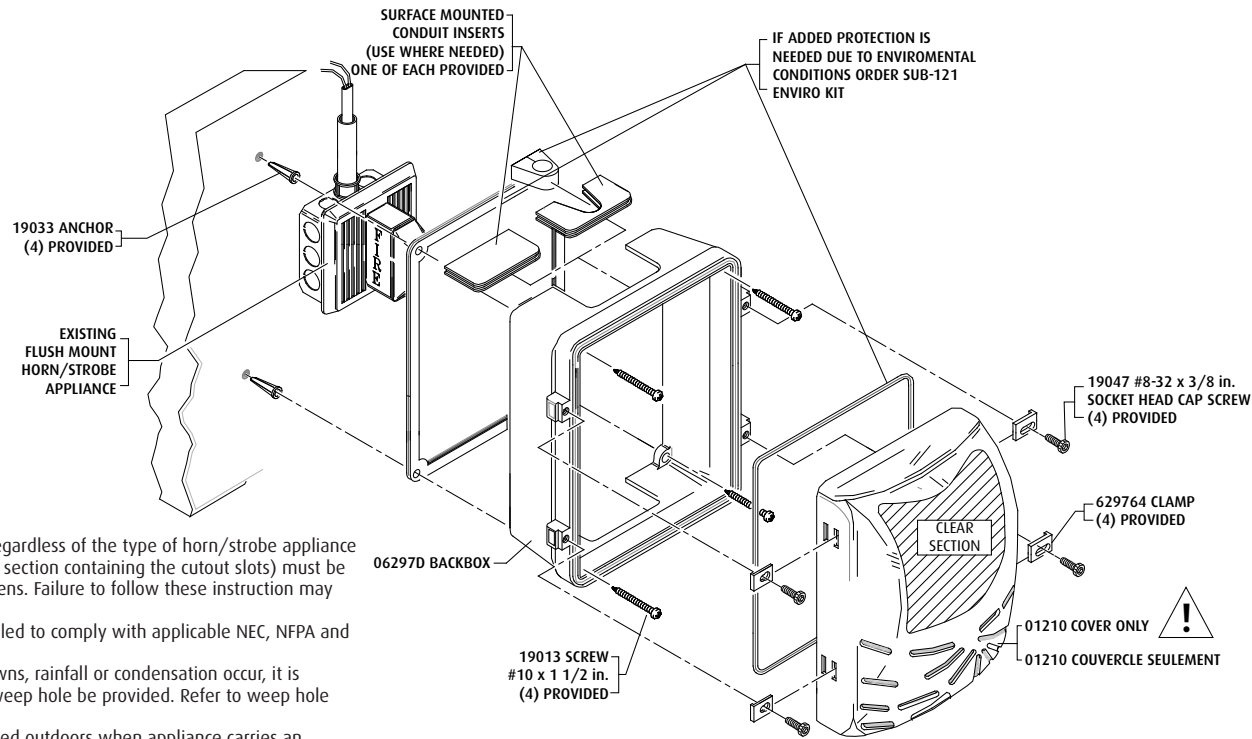

**Safety Technology International, Inc.**  
 2306 Airport Road • Waterford, Michigan 48327-1209  
 Phone: 248-673-9898 • Fax: 248-673-1246  
 Toll Free: 800-888-4784 • E-mail: info@sti-usa.com  
 Web: www.sti-usa.com

**Safety Technology International (Europe) Ltd.**  
 Unit 49G Pipers Road • Park Farm Industrial Estate • Redditch  
 Worcestershire • B98 0HU • England • Tel: 44 (0) 1527 520 999  
 Fax: 44 (0) 1527 501 999 • Freephone: 0800 085 1678 (UK only)  
 E-mail: info@sti-europe.com • Web: www.sti-europe.com



#### INSTALLATION NOTES

1. To minimize strobe light loss, regardless of the type of horn/strobe appliance used, the clear section (not the section containing the cutout slots) must be centered over the strobe light lens. Failure to follow these instructions may lead to light loss transmission.
2. Damage Stopper must be installed to comply with applicable NEC, NFPA and local codes.
3. In applications where wash downs, rainfall or condensation occur, it is recommended that a drain or weep hole be provided. Refer to weep hole installation diagram.
4. Damage Stopper may be installed outdoors when appliance carries an outdoor rating.

#### REMARQUES SUR L'INSTALLATION

1. Afin de minimiser la perte de lumière stroboscopique, quel que soit le type d'alarme sonore/de stroboscope utilisé, la section dégagée (et NON la section contenant les fentes de découpe), doit être centrée sur l'objectif stroboscopique. Le fait d'omettre ces instructions risque d'entraîner la perte de diffusion de la lumière.
2. Le Stopper de dégâts doit être installé de sorte à être conforme avec les normes NEC, NFPA applicables et les codes locaux.
3. Dans les applications où des jets d'eau, des précipitations ou de la condensation se produisent, il est recommandé de prévoir un trou de vidange ou une barbacane. Reportez-vous à schéma d'installation d'une barbacane.
4. Il est possible d'installer un Stopper de dégâts à l'extérieur lorsque l'appareil est homologué pour utilisation à l'extérieur.

#### INSTALLATION INSTRUCTIONS - REFER TO EXPLODED VIEW

1. Using back box assembly as a template, place against mounting surface at proper location according to NFPA 72.
2. Mark and drill (4) holes 1/4 in. (6.3mm) diameter, 1 1/4 in. (32mm) deep.
3. If conduit is present, select the proper inserts and slide them into the back box notch.
4. Insert the (4) anchors into the wall.
5. Mount back box to wall with screws.
6. Install electrical fittings as needed.
7. Install horn/strobe appliance.
8. Install cover with clips and screws.
9. Test appliance according to appliance manufacturer's instructions.

#### CLEANING INSTRUCTIONS

Rinse with water to remove abrasive dust and dirt. Wash with soap or mild detergent, using a soft cloth (do not scrub). Rinse once more then dry with a soft cloth or chamois. To remove grease or wet paint, rub gently with a cloth wetted with naphtha. Then wash and rinse. DO NOT USE RAZOR BLADES.

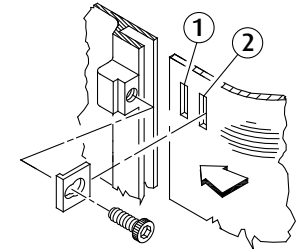

INSTALL CLAMP IN NOTCH 2 AS SHOWN

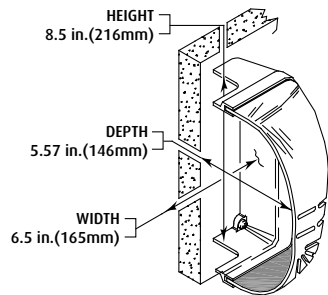

INTERNAL DIMENSIONS

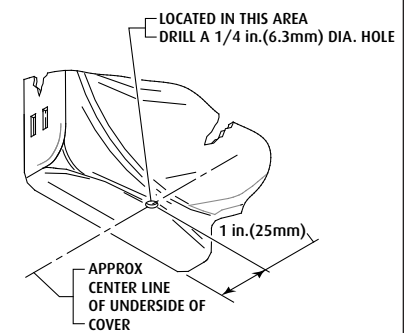

WEEP HOLE INSTALLATION

Electronic warranty form at [www.sti-usa.com/wc14](http://www.sti-usa.com/wc14)



## INSTALLATION OF STI-1210D SPEAKER HORN/STROBE DAMAGE STOPPER®

All specifications and information shown were current as of publication and are subject to change without notice.

1210DIS APRIL2006



## UL INSTALLATION REQUIREMENTS STI-1210 / STI-1221 SERIES

### CAUTION

- This enclosure is rated to protect signaling appliances indoors and in areas of indirect weather exposure. The cover may be used outdoors only with devices also suitable for outdoor use.
- When covering fire-signaling appliances with this enclosure, some light and sound loss occurs. Please follow these guidelines listed during installation.
- Voice speaker appliance: No spacing adjustment is required for 0.5W, 1.0W and 2.0W appliances.
- Refer to the appliance manufacturer's candela rating. Multiply this number by the light loss value from the chart below to determine the new candela rating. Use this number and refer to the notification layout table of NFPA 72 for proper device locations.
- The use of this cover on audible devices decreases the sound output by 6dB(A). Actual sound level output should be checked after installation to determine if adequate sound levels exist. Refer to the notification layout table of NFPA 72 for proper device locations.

### Attention

- Ce boîtier est homologué pour protéger les appareils de signalisation d'incendie à l'intérieur et dans les zones d'exposition indirecte aux intempéries. Le couvercle ne peut être utilisé à l'extérieur qu'avec les appareils appropriés pour une utilisation à l'extérieur aussi.
- Le fait de couvrir les appareils de signalisation d'incendie au moyen de ce boîtier risque d'entraîner une certaine perte lumineuse et sonore. Veuillez vous conformer à ces directives lors de l'installation.
- Haut-parleur: Aucun ajustement de distance n'est nécessaire pour les appareils à tension de 0,5 W, 1,0 W et 2,0 W.
- Reportez-vous à la cote candéla du fabricant de l'appareil. Multipliez cette valeur par la valeur de la perte de lumière du tableau ci-dessous pour déterminer la nouvelle cote candéla. Utilisez cette nouvelle valeur et reportez-vous au tableau de disposition des alertes de la norme NFPA 72 pour les emplacements appropriés de l'appareil.
- L'utilisation de ce couvercle sur les dispositifs sonores diminue la puissance sonore de 6 dB(A). Le niveau réel de la sortie sonore doit être vérifié après l'installation pour déterminer le maintien de niveaux sonores adéquats. Reportez-vous au tableau de disposition des alertes de la norme NFPA 72 pour les emplacements appropriés de l'appareil.

### Performance Review - LIGHT DERATING FACTOR

MANUFACTURER	SERIES	STI-1210	STI-1221/1221A4X	MANUFACTURER	SERIES	STI-1210	STI-1221/1221A4X
ADT SECURITY	ADTG1-V SERIES	40%	34%	HONEYWELL	XLS202 SERIES	40%	34%
AMSECO	SL24W-153075	22%	37%	HONEYWELL	XLSG1-HV SERIES	40%	34%
AMSECO - COLORED LENSES	SL24W-153075 A, B, G, OR R	47%	26%	HONEYWELL	XLSG1-HOV SERIES	40%	34%
AMSECO - COLORED LENSES	SL24C-3075110 A, B, G, OR R	47%	26%	MIRCOM	FS-240	47%	26%
AMSECO - COLORED LENSES	CSL24W-A, B, G, OR R	47%	26%	MIRCOM	MS SERIES	43%	45%
AMSECO - COLORED LENSES	CSL24C-A, B, G, OR R	47%	26%	MIRCOM	MG1-V SERIES	40%	34%
DETECTION SYSTEMS	GES24 SERIES	-	31%	MIRCOM	MG1-HV SERIES	40%	34%
DETECTION SYSTEMS	GES24-15/75	-	-	MIRCOM	MG1-HOV SERIES	40%	34%
EST / EDWARDS	2440S SERIES	43%	45%	MIRTONE	MG1-V SERIES	43%	45%
EST / EDWARDS	202 SERIES	43%	45%	NATIONAL TIME & SIGNAL	GES24 SERIES	-	31%
EST / EDWARDS	G1-V SERIES	40%	34%	NATIONAL TIME & SIGNAL	GES24-15/75	-	-
EST / EDWARDS	G1-HV SERIES	40%	34%	POTTER ELECTRIC	AS-24-153075R	47%	26%
EST / EDWARDS	G1-HOV SERIES	40%	34%	POTTER ELECTRIC	AS-24-153075W	47%	26%
EST / EDWARDS	EG1-V SERIES	40%	34%	SECUTRON	GES24 SERIES	-	31%
EST / EDWARDS	EG1-HV SERIES	40%	34%	SECUTRON	GES24-15/75	-	-
EST / EDWARDS	EG1-HOV SERIES	40%	34%	SIEMENS	202- SERIES	43%	45%
FARADAY LLC	2700	-	57%	SIEMENS	G1-V SERIES	40%	34%
GENTEX	GES24 SERIES	-	31%	SIEMENS	U-MCS SERIES	-	-
GENTEX	GES24-15/75	-	-	SYSTEM SENSOR	SS24110ADA	46%	37%
HARRINGTON SIGNAL	GES24 SERIES	-	31%	SYSTEM SENSOR	P2, PC2, P4, PC4, SX, SC	53%	61%
HARRINGTON SIGNAL	GES24-15/75	-	-	WHEELock	RSS-24MCW	-	-
HONEYWELL	XLSG1-V SERIES	43%	45%	ZITON PTY LTD	ZG1-V SERIES	40%	34%

STI-1210 Series Sound Derating Factor: System Sensor P2, PC2, P4, PC4, SX, SC series models: 6.7 dBA, General: 6 dBA

STI Generic Light Loss Value: STI-1210 Series: 53%; STI-1221 Series: 61%