

STI STOPPER II® WITH “A” BACKBOX



STI-1200A

ADA
Compliant

PRODUCT OVERVIEW

This protective cover has been helping stop malicious and accidental false fire alarms around the world for over 30 years, without restricting legitimate alarms. This version of the Stopper II has a four inch deep enclosed backbox which allows it to be installed in wet or wash down areas (such as kitchens, cafeterias, meat packing plants, showers, outdoors, etc.). It helps protect against physical damage (both accidental and intentional), dirt and grime. The enclosure is not locked which makes it easy to open for legitimate operation.

HOW IT WORKS

STI-1200A consists of a clear, tamperproof, tough polycarbonate shield, a housing for an instructional operation label, gasket, conduit hub and a four inch deep backbox. The standard STI-1200A accommodates most manual pull stations and is marked with an “In Case of Fire” message, but can be custom labeled and used to protect other devices. The cover allows an outdoor rated addressable manual pull station to be installed in wash down areas.

KEY FEATURES

General Information

- Proven effective for more than 30 years in helping stop false fire alarms without restricting legitimate alarms.
- Can be used as a guard against physical damage to a manual pull station.
- Three year guarantee against breakage of polycarbonate in normal use.

Design

- Cover includes four inch deep back box.
- Not locked, easy to open.
- The Stopper II design is a registered trademark of Safety Technology International, Inc.

Construction

- UL Listed, ADA Compliant for operation.
- The thick, clear polycarbonate cover is UV-stabilized.

Installation

- Typical working properties of polycarbonate are -40° to 250°F (-40° to 121°C).

Options

- Comes standard with an “In Case of Fire - Lift Cover Pull Fire Alarm” label.
- Custom label available for a fee.



For more information, call 1-800-888-4784 (4STI) or visit www.sti-usa.com

**Safety Technology
International, Inc.**

STI Stopper II® with "A" Backbox

Dimensions and Technical Information

MODEL AVAILABLE

STI-1200A Stopper II with 4 inch deep backbox

APPROVALS & WARRANTY

TESTING

It has been tested and approved or listed by:

- Underwriter Laboratories No. S2466.
- ADA Compliant.
- The station cover, when mounted on a smooth surface, provides a rain tight seal similar to a 3R enclosure rating.

WARRANTY

Three year guarantee against breakage of polycarbonate in normal use.

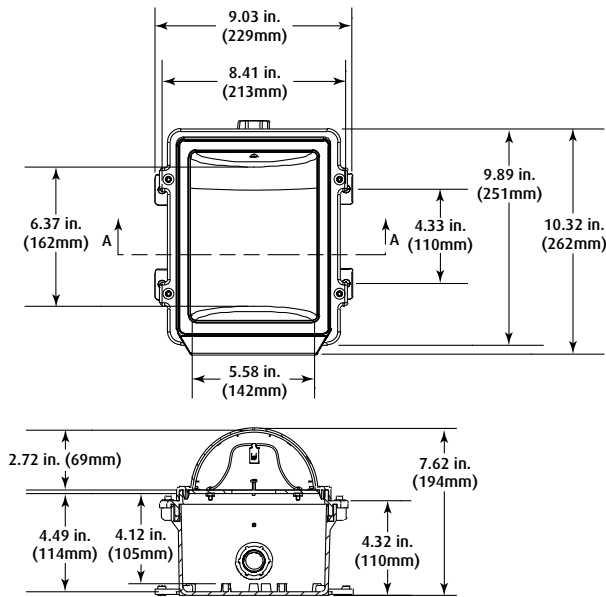

A-A

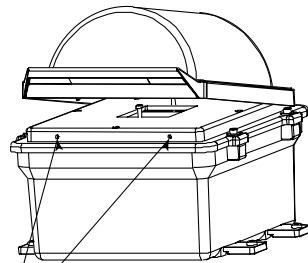
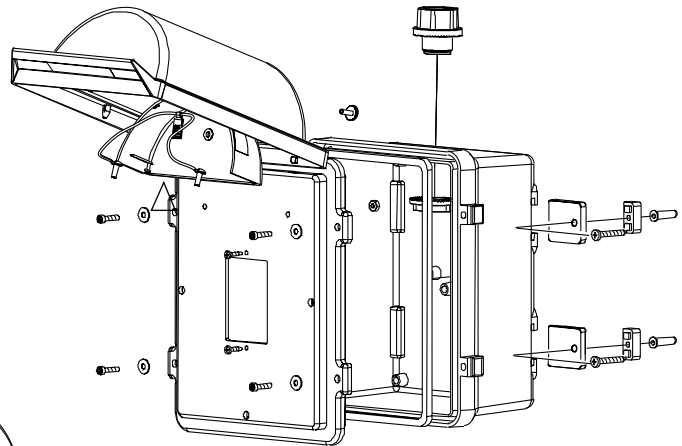

IMPORTANT NOTE: FOR WET OR WASHDOWN AREAS, STI RECOMMENDS DRILLING (2) 1/8 in.(3mm) DIAMETER WEEP HOLES IN THIS AREA TO PREVENT THE BUILD-UP OF WATER INSIDE THE ENCLOSURE WHICH MAY CAUSE DAMAGE TO ELECTRONIC COMPONENTS

AVIS IMPORTANT: DANS LE CAS DES ZONES HUMIDES OU À APPLICATIONS SANITAIRES, STI RECOMMANDE LE PERÇAGE DANS CES ZONES DE DEUX (2) BARBACANES DE 1/8 PO (3 MM) DE DIAMÈTRE AFIN D'ÉVITER L'ACCUMULATION D'EAU DANS LE BOÎTIER, CE QUI RISQUE D'ENDOMMAGER LES COMPOSANTS ÉLECTRONIQUES



Safety Technology International, Inc.

2306 Airport Road
Waterford, Michigan
48327, USA

Tel: 248-673-9898
Fax: 248-673-1246
Toll-free: 800-888-4784
info@sti-usa.com
www.sti-usa.com

Unit 49G Pipers Road
Park Farm Industrial Estate
Redditch, Worcestershire
B98 0HU England

Tel: 44 (0) 1527 520 999
Fax: 44 (0) 1527 501 999
www.sti-europe.com